



Expedite Station Canada Vancouver International Airport Amendment

Additional Requirement:

A Load Center is to be provided to separate the individual circuits of the Expedite Station with an Emergency Shut off Switch

Component Locations

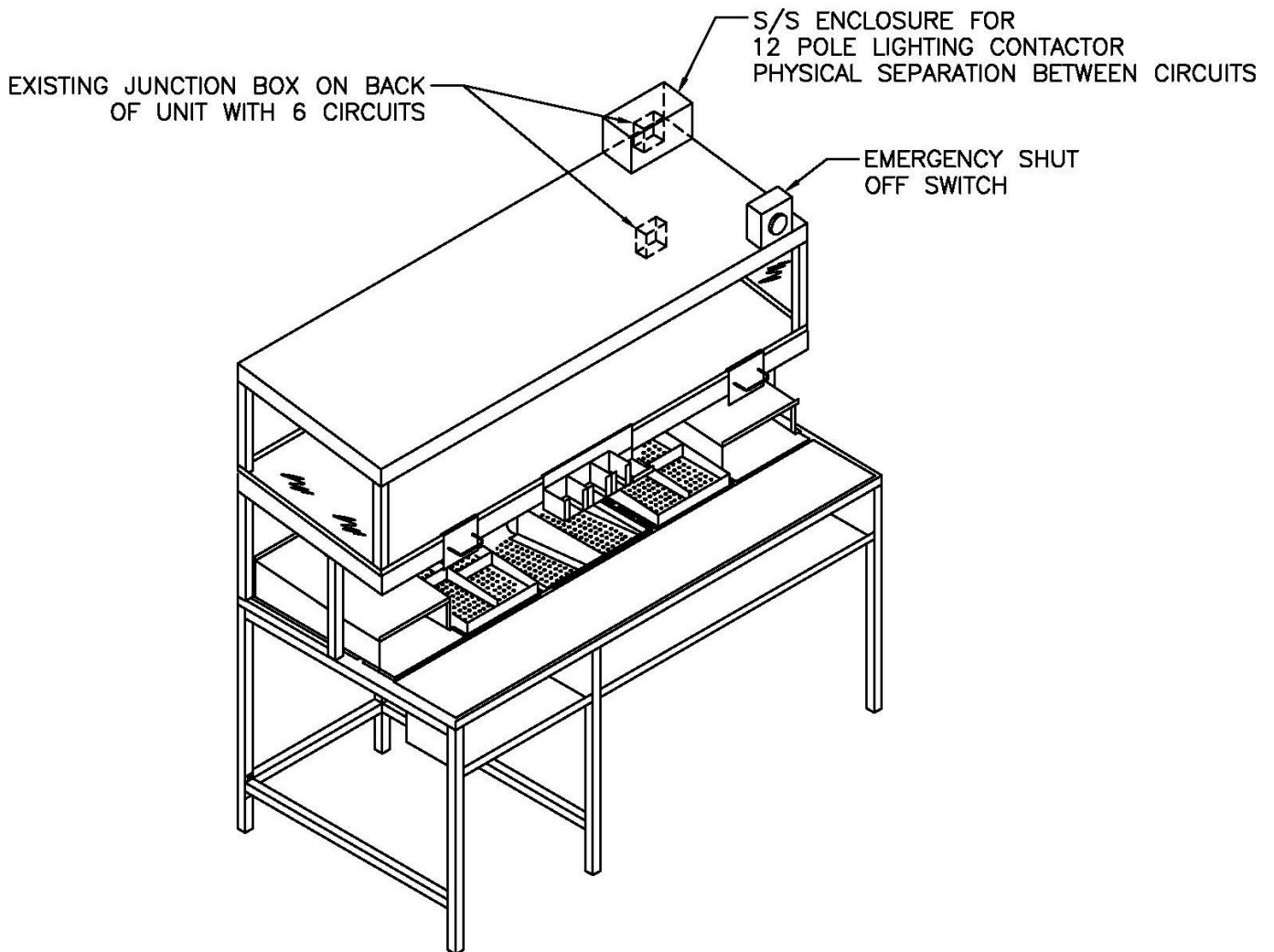

Expedite Station

Canada Vancouver International Airport Amendment

Ladder Diagram

