

# ULTRAFRYER<sup>®</sup> SYSTEMS

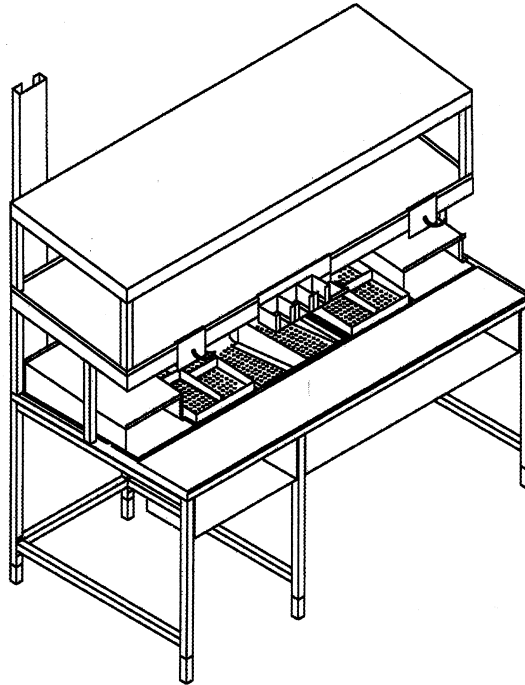

## EXPEDITE STATION ASSEMBLY INSTRUCTIONS (84" VERSION)

Manufactured by:



302 Spencer Lane • P.O. Box 5369 • San Antonio, Texas 78201  
Telephone: (800) 525-8130 • (210) 737-5734 • FAX: (210) 737-5748

## I UNPACKING

- A. **CAREFULLY** remove the packing material from the Expedite Station and check each item for visible damage. If damage is found **DO NOT** refuse shipment but **DO** contact the carrier and file the appropriate freight claims.
- B. Unwrap, remove and temporary set aside all parts and accessories packed in cartons.
- C. Place the following **MAJOR** components, identified below, in separate areas to facilitate assembly of the Expedite Station:
  1. **BASE ASSEMBLY** – The base assembly consist of: base top; two (2) base top channels; left hand, center and right hand base legs; long and short stretcher bars; long and short bag and box shelf; and an apron.
  2. **SIDE ITEM WARMER**
  3. **CHICKEN WARMER**
  4. **WIRE CHASE AND WIRING HARNESS**

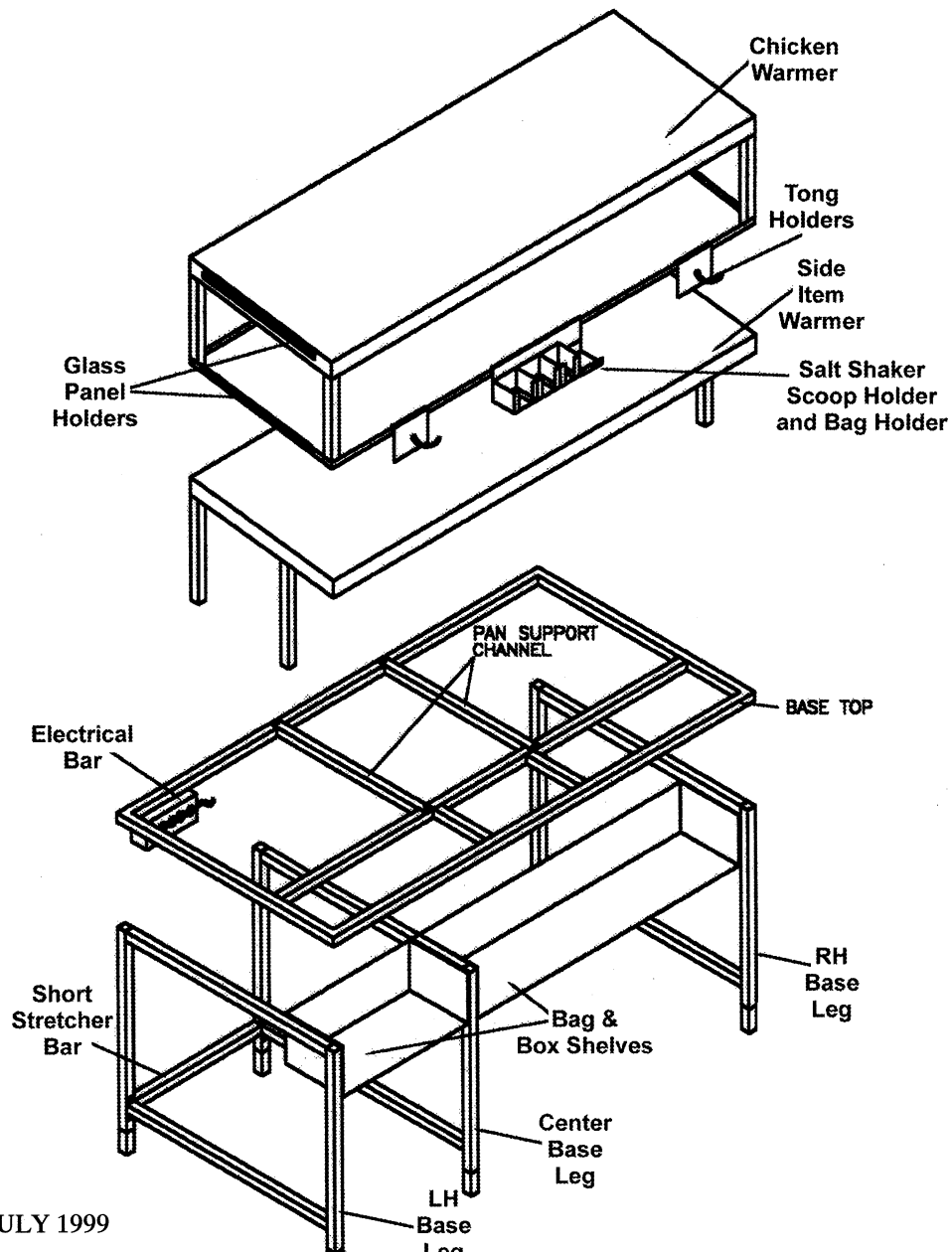

5. **BAG AND BOX DIVIDERS; BISCUIT AND PRODUCT HOLDERS; PANS, SCREENS AND DIVIDERS; AND GLASS PANEL HOLDERS AND GLASS**

**II ASSEMBLY SEQUENCE**

**A. BASE ASSEMBLY** - assemble the base assembly as follows:

1. **CAREFULLY** place the base top on the floor with the three (3) ¼ - 20 **WELD STUDS** on each side facing **UPWARD**.
2. Position the **LH** base leg with the three (3) ¼” holes in the top bar over the weld studs on the **LEFT** side of the base top so that the two (2) 10-24 nutserts in the **REAR** leg are facing **INWARD**; then secure the leg to the top using three (3) lock washers, ¼-20 hex nuts and acorn nuts provided.
3. Position the **RH** base leg with three (3) ¼” holes in the top bar over the weld studs on the **RIGHT** side of the base top so that the two (2) 10-24 nutserts in the **REAR** leg are facing **INWARD**; then secure the leg to the top using three (3) lock washers, ¼-20 hex nuts and acorn nuts provided.
4. Position the **CENTER** base leg with one (1) ¼” hole in the top bar over the weld stud in one of the center bars of the base top with the mounting plate containing two (2) 9/32” holes to the **REAR**, then secure the leg to the top by installing a lock washer, ¼-20 hex nut and acorn nut on the weld stud, and two (2) 10-24 truss head screws in the nutserts on the rear bar of the base top.
5. Position the **SHORT** stretcher bar on the **LH** and **CENTER** base legs and secure it to each leg using two (2) 10-24 truss head screws in the nutserts on each leg.
6. Repeat step 5 to secure the **LONG** stretcher bar to the **CENTER** and **RH** base leg.
7. **CAREFULLY** place the base assembly **UPRIGHT** with the three (3) narrow openings to the **FRONT**, place the assembly in the position where it is to be used; then check to be sure it is **LEVEL**. If necessary, adjust the bullet feet on the base legs to level the assembly.
8. Position the **SHORT** bag and box shelf beneath the **LEFT** side of the base top and secure it to the base top and legs by installing a 10-24 truss head screw in each nutsert.
9. Repeat step 8 to install the **LONG** bag and box shelf beneath the **RIGHT** side of the base top.
10. **CAREFULLY** place the **APRON** in the opening above the bag and box shelves so that the “**L**” shape brackets on the apron are seated between the bars of the base top.
11. Place the two (2) base top **CHANNELS** to the **REAR** of the base top but **DO NOT** secure them to the base top.

**B. SIDE ITEM WARMER**

1. **CAREFULLY** position the side item warmer on the base assembly with the four (4) legs **SEATED** on the two (2) **ANGLED TABS** on both sides of the base top.
2. Align the 9/32" hole in each leg of the warmer with the nutsert in each **TAB**; then secure the warmer to the base assembly by installing a 10-24 truss head screw in each nutsert.

### C. CHICKEN WARMER

1. **CAREFULLY** position the chicken warmer on the side item warmer where the 10-24 **WELD STUDS** along the **FRONT** and **REAR** edge of the chicken warmer are seated in the 9/32" holes along the **FRONT** and **REAR EDGE** of the side item warmer.
2. When each weld stud is properly **SEATED** in each 9/32" hole, secure the chicken warmer to the side item warmer by installing a #10 cap speed nut on each weld stud

### D. WIRE CHASE AND WIRING HARNESS

**NOTE:** Perform the following step facing the **REAR** of the Expedite Station.

1. Remove the four (4) #10 cap speed nuts from the weld studs along the side of the two (2) warmers; and the two (2) 10-24 truss head screws from the nutserts on the right side of the base top and electrical box rear panel.
2. Position the wire chase along the **RIGHT** side of the warmers; insert the two (2) 4 pin white plastic connectors and one (1) 2 pin white plastic connector attached to the side item warmer through the **LOWER** 1 3/8" hole in the chase; insert the two (2) 4 pin white plastic connectors attached to the chicken warmer through the **UPPER** 1 3/8" hole in the chase; and insert the 2 pin white plastic connector with two (2) **BLACK** wires and the other **SIX (6)** wire from the electrical box through the **BOTTOM** 7/8" hole in the electrical chase. **CAREFULLY** place the wire chase against the warmers with the four (4) 10-24 weld studs inserted in the 9/32" holes in the wire chase; then **SECURE** the wire chase to the warmers using the four (4) #10 cap speed nuts and 10-24 truss head screws removed earlier.
3. **SECURELY** connect the white plastic connectors on the wire harness in the wire chase as follows:
  - a. Connect the **UPPER** 4 pin connector with **BLACK** wires to the 4 pin connector with **BLACK** wires attached to the chicken warmer.
  - b. Connect the **UPPER** 4 pin connector with **WHITE** wires to the 4 pin connector with **WHITE** wires attached to the chicken warmer.
  - c. Connect the **LOWER** 4 pin connector with **BLACK** wires to the 4 pin connector with **BLACK** wires attached to the side item warmer.
  - d. Connect the **LOWER** 4 pin connector with **WHITE** wires to the 4 pin connector with **WHITE** wires attached to the side item warmer.
  - e. Connect the **UPPER** 2 pin connector with **BLACK** wires to the **UPPER** 2 pin connector with **BLACK** wires attached to the side item warmer.
  - f. Connect the **LOWER** 2 pin connector with **BLACK** wires to the **LOWER** 2 pin connector from the electrical box; route the other six (6) wires from the electrical box (one **WHITE** 12 gauge wire, two **RED** 10 gauge wires, one **GREEN** 10 gauge wire and two **WHITE** 10 gauge wires) up the wire chase then secure them to the chase with the "C" clamp provided.
4. **SECURE** the wire chase cover to the wire chase by installing a 10-24 truss head screw in each nutsert on the chase.

5. Position a glass panel holder with one (1) glass **CHANNEL** over the shoulder bolts on the right side of the lamp section of the Chicken Warmer; then seat it on the shoulder bolts. Position a glass panel holder with two (2) glass **CHANNELS** over the shoulder bolts on the right side of the chicken tray section of the Chicken Warmer with the **STOP FLANGE** facing **UP** and to the **FRONT** of the Expedite Station; then seat it on the shoulder bolts.
6. Repeat step 5 above to install the remaining glass panel holders on the left side of the Chicken Warmer.
7. The biscuit pan heating pads and heat lamps in the chicken and side item warmers require a maximum of 98 amps at 120 volts electrical power for proper operation. If a heated holding cabinet and/or undercounter freezer is to be connected to receptacles on the Expedite Station electrical box, additional electrical power will be required.

### **III CLEANING**

- A. **THOROUGHLY** wash the bag and box shelves, chicken warmer and side item warmer with **HOT** soapy water to remove oil film, manufacturing residue, etc; rinse; and then wipe these items dry with a lint free cloth.
- B. **INSPECT** the chicken and side item warmers which will come into contact with food for crevices that have not been sealed with silicone. Any crevices found **MUST** be sealed with clear food grade silicone.
- C. **THOROUGHLY** wash the following items with **HOT** soapy water to remove oil film, manufacturing residue, etc; rinse and wipe dry with a lint free cloth:
  1. Bag and box shelf dividers
  2. Biscuit pan holder
  3. Product dump pan, screen and divider
  4. Side order pan, screen, divider and grill
  5. Salt, scoop and bag holder and tong holders
- E. Remove stickers from the glass panels and, carefully wash these panels with hot soapy water, rinse and wipe dry with a lint free cloth; then **CAREFULLY** install these panels by sliding them into the glass panel holders from the **REAR** of the Expedite Station.

### **IV ACCESSORIES INSTALLATION**

- A. Place the eight (8) dividers in each bag and box shelf spaced for the size of bags and boxes used.
- B. Place the salt, scoop and bag holder in the center of the chicken warmer, and place a tong holder on each side of the salt, scoop and bag holder.

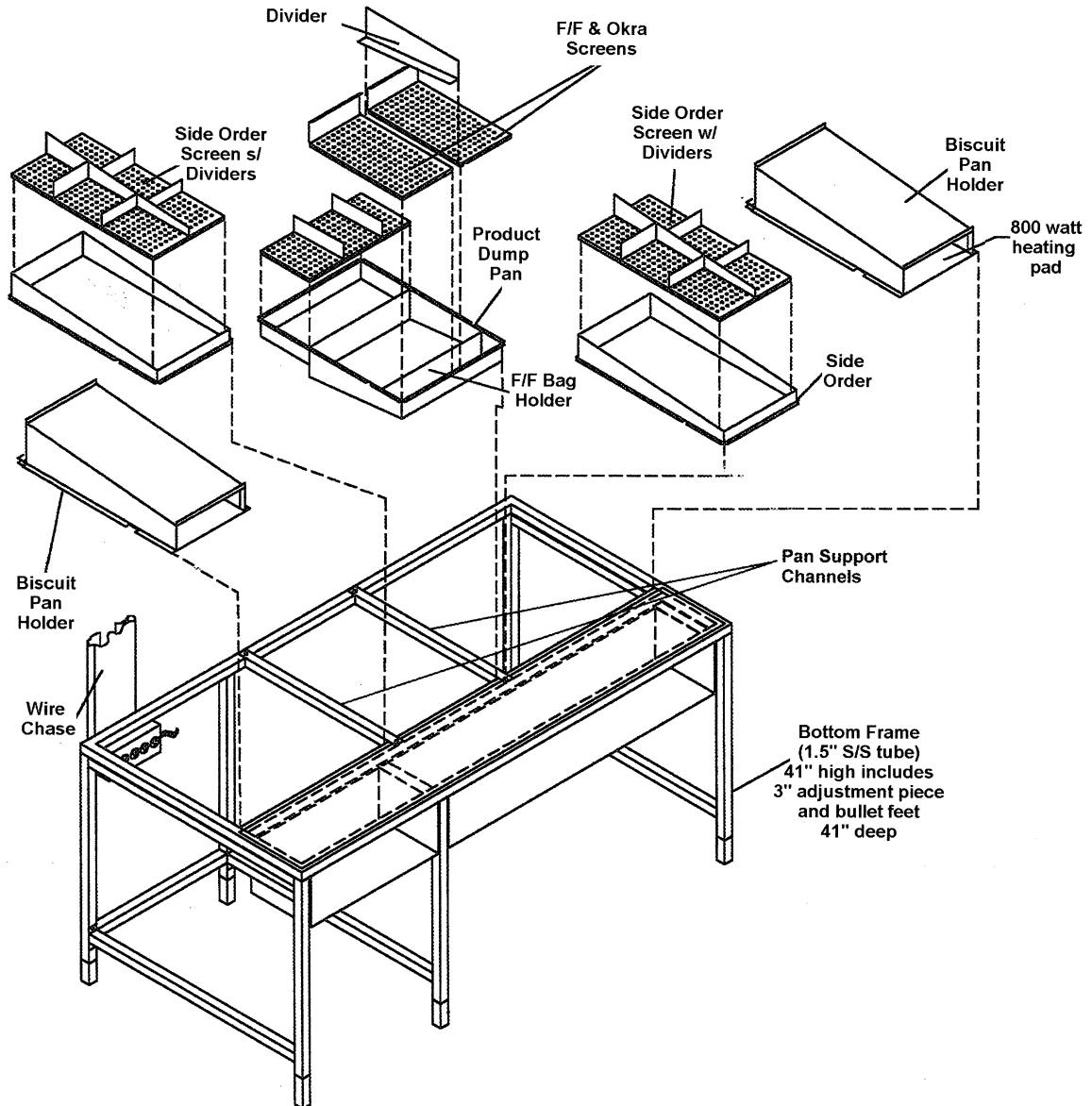

C. Assemble and install the following in the side item warmer as shown above:

1. **LEFT** and **RIGHT** biscuit pan holder. When in position, connect the electrical plug for each biscuit pan heating pad in a single 20 amp receptacle on the electrical box.
2. Confer with the area/store manager to determine how he wants the product dump pan and two (2) side item pans arranged on the base top; then position and secure the two (2) pan support **CHANNELS** to the base top using 1/8" pop rivets.
3. Insert the product dump pan and the two (2) side item pans, screens and dividers into the expedite station according to the managers instructions.

D. Place the two (2) bag holders beneath the apron at the positions designated by the store manager.

**V. HEATED HOLDING CABINET/UNDERCOUNTER FREEZER**

- A. If applicable, position the heated holding cabinet according to the manager's instructions and connect its electrical plug to the **LARGE** 30 ampere outlet on the electrical box.

**NOTE:** If the heated holding cabinet has **COOLING LOUVERS** on the **TOP** and it is placed **BENEATH** the Expedite Station, push the cabinet to the rear until the **LOUVERS** are **BEHIND** the bag and box shell.

- B. Place the undercounter freezer in position according to the manager's instruction and connect its electrical plug to a 20 ampere outlet on the electrical box.

# VI EXPEDITE STATION LADDER

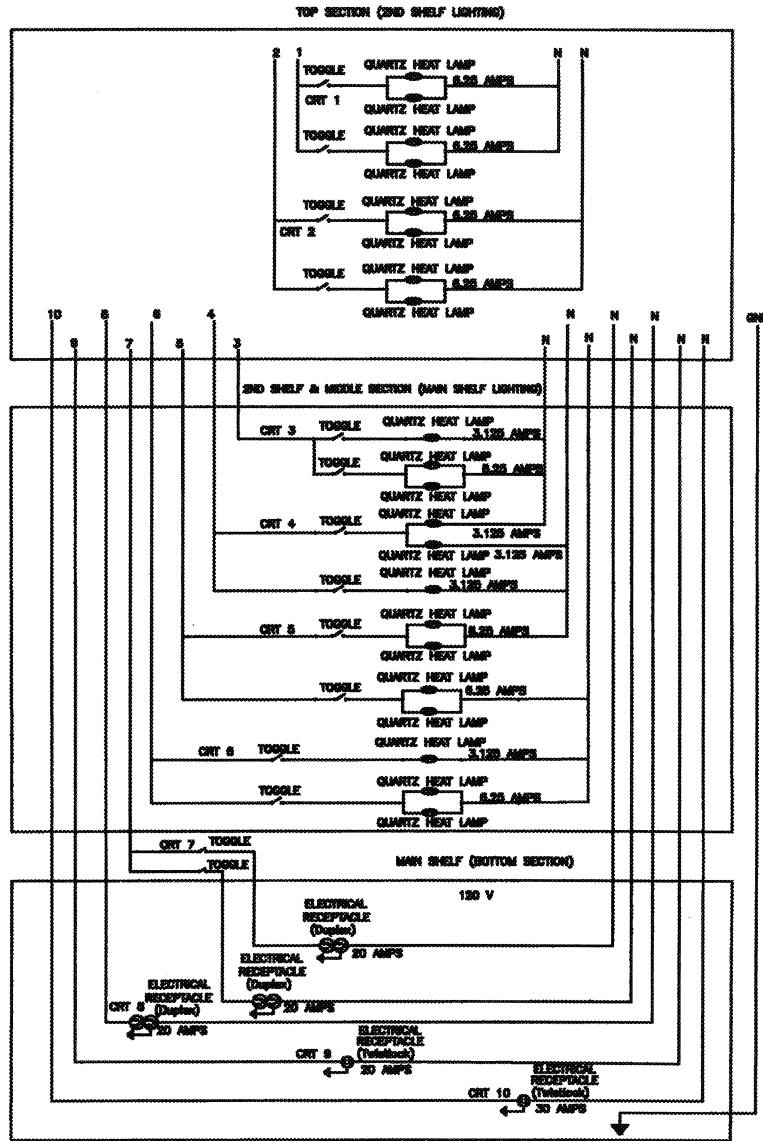

LADDER DIAGRAM FOR 84" MICROSTATION  
11A434 / 11A501

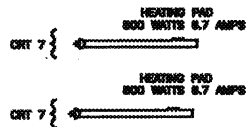

## 84" MICROSTATION LADDER



