

# UltraGold™ 14 Electric Series

## F-E17-14

The UltraGold 14 electric fryer packs the power of a large fryer in a smaller footprint.

This model has a single, 14 in. vat with a 35-45 lb. oil capacity. You also have the option to connect up to six vats using vat joiner strips.

The UltraStat® 23 controller, which includes ten keys for easy menu programming, allows you to maintain consistent temperatures and hold times.

The UltraGuard™ automatic melt cycle gently brings shortening to temperature to prevent scorching and overheating.

Please note that cord sets and plugs are not included.



### STANDARD FEATURES

- Energy Star® rated
- High-efficiency flat bar heating element
- UltraStat® 23 computer controls
- One vat
- All stainless steel construction
- Heavy-duty casters
- Drain cleaning rod and vat cleaning brush
- UltraGuard™ automatic melt cycle with vat protection
- Two baskets (12.25"L x 5.8"W x 6.75"D)
- Available in 208v or 240v
- Drain board

### OPTIONS

- Add up to six vats using vat joiner strips

### ACCESSORIES

- Vat joiner strip to connect two or more
- Splash guard (left and/or right side)
- Vat cover

Project \_\_\_\_\_

Item \_\_\_\_\_

Quality \_\_\_\_\_

Approval \_\_\_\_\_

Date \_\_\_\_\_



# Ultrafryer®

# UltraGold™ 14 Electric Series

## F-E17-14

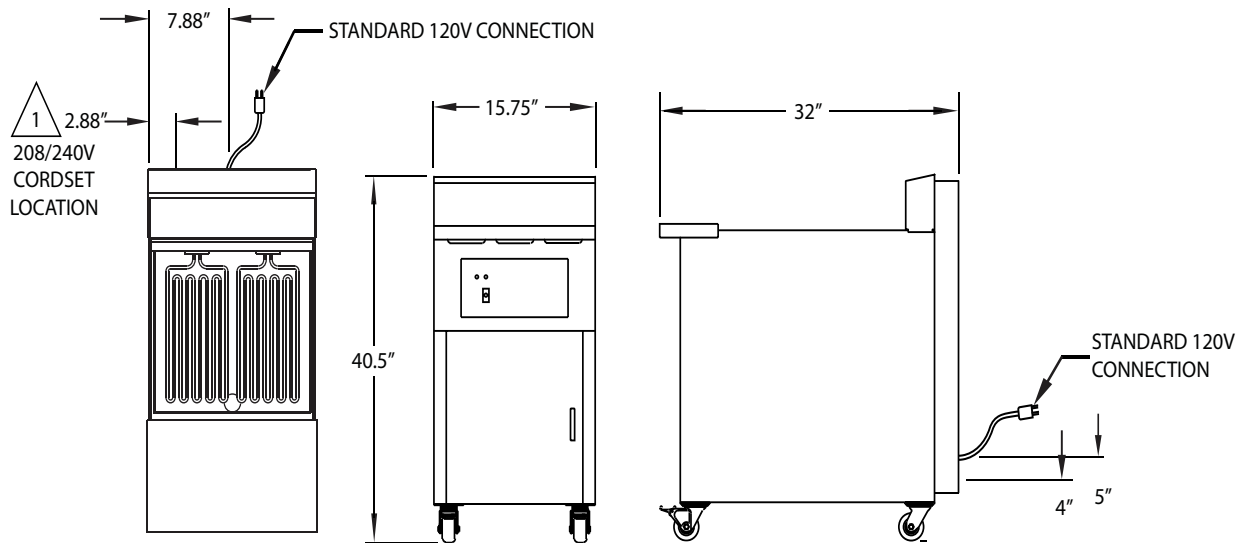

Sales ID#	Oil Capacity	Overall Size (H x D x W)	Nominal Vat Size	Net Weight	Shipping Info
B-E17-14	35-45 lb (22 L) per vat	40.8" x 33.7" x 15.75" (1070 x 856 x 400 mm)	14" x 14" (355.6 x 355.6 mm)	250 lb (113.4 kg)	F.O.B. Factory San Antonio, Texas

Performance determined in accordance with ASTM F1361-91 Standard Test Method for the performance of open vat fryers. Energy input rating 17 kW min.

### CONTROLLER ELECTRICAL REQUIREMENTS

120 V, 60 Hz, 1 phase, 8.5 A

Electrical cord is 6' long and located on rear right-hand side (control circuit).

### ELECTRICAL SPECIFICATIONS

Model	Voltage 60 Hz	Phase	kW	Amps
18"	208	3/3w	17	47 per vat
	240	3/3w	17	41 per vat

### HEATING ELEMENT & VAT CONFIGURATION

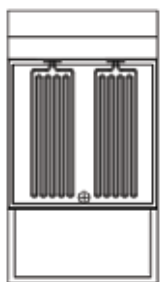

Electric



Flat bar element

1

1 vat

© 2017 Ultrafryer Systems, Inc. Due to continuing engineering development and improvements, specifications are subject to change without notice. Ultrafryer Systems, Inc. is a wholly owned subsidiary of Standex International Corporation. Revision date: 1.15.2019

# Ultrafryer®