

ULTRASTAT25

Ultrafryer Computer Operation Instruction



302 Spencer Lane · P.O. Box 5369 · San Antonio, Texas 78201
(800) 525 - 8130 · (210) 731 - 5000 · Fax: (210) 731 - 5099

PREFACE

This manual was written and published by the Technical Publications Department, Ultrafryer Systems, for use by store personnel who operate an Ultrafryer Fryer equipped with the Ultrastat25 Cooking Computer. This manual complements and should be used in conjunction with the Ultrafryer Fryer Maintenance and Repair Manual provided with each Ultrafryer Fryer.

TECHNICAL PUBLICATIONS DEPARTMENT ULTRAFRYER SYSTEMS

302 Spencer Lane
San Antonio, Texas 78201
1-800-545-9189 Ext. 5007

NOTE: This Manual is applicable to both Electric and Gas Fryers equipped with an Ultrastat 25 Cooking Computer.

TABLE OF CONTENTS

I. Introduction	
Ultrastat25 Computer Filter / Shortening Management	4
Safety	7
Safe Cleaning Procedure	7
II. Ultrastat25 Cooking Computer	
Computer Control Panel	8
Computer Features	9
Computer Panel Key Descriptions	10
Display Descriptions	11
Operating the Computer	12
III. Ultrafryer Ultrastat25 Computer Operating Instructions	
Turning the Ultrastat25 Computer On/Off	14
Melting Shortening	15
Operating the Computer	17
Ultrafryer Boil-Out	19
IV. Ultrastat25 Computer Settings and Programming	
Program Displays	21
Ultrastat 25 Computer Programming	23
V. Wiring Diagrams	28

WARNING: The unauthorized use or duplication of the software described herein, or this material, is strictly prohibited

I. INTRODUCTION

This computer is designed to simplify the timing process and allow operators to spend more time with customers and other important responsibilities. Quality control of cooked products is assured through the various features, notification displays and alarms designed into the computer.

A. ULTRASTAT25 COMPUTER FILTER / SHORTENING MANAGEMENT

1. Measuring, Tallying, and Checking Shortening Degradation

The first principle of FM/SM is knowing how “used” the shortening is. Cooking causes changes and “impurities” in shortening and the effect varies with cook time, cook temperature, breading, cooking load, ice particles and other factors difficult to name and quantify .

In the U25 controller cooking buttons (product keys) are programmed for time and temperature and labeled for a certain kind of product. It is also possible to program into each product key a measure of the shortening degradation experienced with each cook of the intended product. Rather than use a measure (such as pieces or pounds) which does not totally represent the whole of shortening degradation factors the unit of measure is the **HIT**.

Defining HITS - Each restaurant or chain of restaurants determines how much degradation to associate with each cooking of each product and devises a system so that the cooking “drops” planned from the least harsh to the most harsh degradation may be represented by a series of whole numbers. For instance, cooking one pound of unbreaded french fries is the least degrading cook drop planned. The research chef would assign a small whole number of hits, say 3. The button for one pound would be programmed for 3 hits. The product key cooking 2 pounds at a drop would be programmed for 2 times 3 or 6 hits.

Cooking 5 pounds of breaded veal cutlets might be determined to degrade the shortening 5 times as bad cooking one pound of unbreaded fries. The product key for 5 pounds of breaded veal cutlets would be programmed for 5 times 3 or 15 hits.

The research chef then decides how used he wants his shortening to be before it is to be filtered and how used it must be before it is to be discarded. If he decided shortening should be filtered after cooking the equivalent of 5 drops of 5 pounds of breaded veal cutlets he would indicate that filtering should be done after 5 (drops) times 15 (veal cutlet hits) or 75 hits. He would then program the feature key associated with filter hits (FK7) with a limit of hits before the filter message is to be displayed. This quantity is labeled **FHCL** (for filter hit count limit) and this would be set to 75. Any consistent set of units would do so long as the hits on the product keys and the hit limit on the 7th feature key were defined to be the measure of the same degree of degradation.

Checking the HIT Count - When the total of filter hits (viewable as **FHCS** in feature key 7 or by pressing the “**O**” key when in the ready mode) reaches the **FHCL** (in our example 75) the controller displays **FILTER** as a message alternating with other messages (such as **READY**) to indicate filtering is recommended.

Some restaurants may want to use an option of the filter management (**FM/SM**) system as an added caution. The U25 measures how long the fryer has been **ON** since the last filtering. It is possible to set in product key 7 the value of **TIME** in hours. When the vat has been on for that amount of time a **FILTER** message will be displayed. This is because after only a few drops to add impurities the shortening will degrade from just idling at a high temperature.

The elapsed time since filtering may be viewed when in the ready mode by pressing the “O” key a second time to see **FTP** (filter time prompt) in units of **HH:MM**. When **FTP** exceeds **TIME** the **FILTER** message is displayed. The restaurant manager may check the amount of cooking and the amount of time since filtering on every fryer vat. The appearance of the **FILTER** message indicates whether or not either the time or cooking hit count sum has exceeded the limit, but the manager can also know how close to the limit each parameter is.

Disposal Limit - The restaurant research chef may also define the number of hits of shortening degradation, regardless of the filtering done the period since last disposal, at which the **DISPOSAL** message is displayed. For instance, and using the hits as defined in the example above, the restaurant might filter twice a day and the filtering may conveniently occur after the 75 hits each time. In such instances the chef determines his shortening would last 6 days and still provide the quality desired. He would then want the disposal hit limit set at 75 (ideal hits between filterings) times 2 (ideal filterings per day) times 6 (days of ideal usage and filtering) or 900 hits. This is done by programming **DHL** (disposal hit limit) in feature key **8** to a value of **900**.

Heavier usage over the period would cause 900 hits to be reached before the customary 6 days. This information would allow the manager to possibly modify his disposal plans. The actual number of hits can be viewed by going to feature key **8** and looking at **DHC** (disposal hit count).

- 2. Help in the Filtering Process** - The U25 provides timing help and display guidance in the filtering process and sets the **FHCS** (Filter Hit Count Sum) to zero after the timing aid has been used. It assumes proper filtering has then been done and since the Ultrafryer® gas or electric fryers provide many features to make filtering effective and user friendly it usually will have been.

Ultrafryer® fryers with built in shortening return filter systems have a main power switch that directs the incoming control power to either the heating controls (contactor circuit or gas valve circuit) or the pump controls. In addition a drain valve switch also removes the power from the heating control circuits. When either or both of these switches are put in the position for shortening handling the U25 switches from the heating mode to the filtering mode. It indicates this by displaying **DRAINING** rather than **READY** in the display window. If the **FILTER** message had been displayed during the heating mode, it will now alternate with the draining message in the display. If the **FILTER** message was not yet displayed the **DRAINING** message will alternate with **TURN OFF**. If filtering is desired, the user leaves the U25 soft ON/OFF switch in the **ON** position and follows the filtering procedure. If the main power switch was turned “**OFF**” for closing down the fryer for an off period without filtering the soft ON/OFF switch is turned to off.

Using the Timing Aid - The filtering procedures in the fryer manual for your particular filter system configuration should be followed without regard to the U25. During the procedure a polishing period is often called for .

If and when the polishing step is initiated the timer button on the U25 should be pressed. A 10 minute count-down will begin. If the step is finished before 10 minutes press the **OK/EXIT** button. The U25 display now says **CLOSE DRAIN** indicating the filter hit count sum has been set to zero and refilling may begin.

If using a filter system in which polishing is not required, press the timer button for the wash wand, bottom sweep, or automatic vat cleaner operation. When finished (if less than 10 minutes) press **OK/EXIT** to turn off the timer. The U25 will display **CLOSE DRAIN** indicating the filter hit count sum has been set to zero and refilling may begin.

Closing the drain will not make this message disappear because the main power switch for the vat just filtered should still be in the pump position. The **CLOSE DRAIN** switch will remain until the vat is refilled and the main power switch is returned to the heat position from the pump position. Only then will the **DRAIN-FILTER-REFILL** cycle be completed and the **DRAIN-FILTER-REFILL** switches be closed.

If using an external pump or the self cleaning pump nozzle control to refill the vat it is possible (but forbidden) to pump while the vat power switch is on. In this case closing the drain will return the U25 to the “ready for turning on to the heating mode” condition. For safety reasons the user must refill the vat before attempting to return the U25 to heating mode. As a precaution the U25 does not go **ON** when all the mechanical fryer switches are restored to the heat position, but goes to the **TURN OFF** mode and displays the message **TURN OFF** .

3. **The Disposal Procedure** - When the **DHC** (disposal hit count) reaches the **DHL** (disposal hit limit) the **DISPOSE** message is displayed. Since Disposing means filtering isn't required it displaces the filter message. When the shortening is discarded it is necessary to manually reset the **DHC** value, since the U25 has no inputs with which to automatically detect that disposal has occurred. Setting the **DHC** to zero will also zero the filter hits and filter elapsed time counters.
4. **Summary** - The U25 can be used to give important information about shortening care and usage. If not desired, the messages may be opted out by setting **FHCL**, **DHL** and **TIME** to zero in the feature programming mode. If management has elected to use the information it is most valuable when the user is trained in the meaning of the messages and values, the filtering process, the reasons for filtering and the value and cost of good shortening.

Appendix

Glossary of parameters:

FHCL - Filter Hit Count Limit: The number of total hits from the cooking with any combination of the product keys at which the **FILTER** message is to be displayed.

FHCS - Filter Hit Count Sum: The number of total hits from the cooking with any combination of the product keys since the last filtering.

TIME - The number of hours of being ON before the **FILTER** message is displayed.

FTP - Filter Time Prompt: The number of hours and minutes (**HH:MM**) since the last filtering.

DHL - Disposal Hit Limit: The number of total hits from the cooking with any combination of the product keys at which the **DISPOSE** message is to be displayed.

DHC - Disposal Hit Count: The number of total hits from the cooking with any combination of the product keys since the last disposal.

- B. SAFETY** - The Ultrastat25 Cooking Computer operates on 24 volt single phase electrical power, and like other electrical equipment, it should not be operated with wet hands or while standing in water. Water should **NEVER** be sprayed on or at the computer, as there is a danger of electrical shock and / or serious damage to the computer circuitry. Should the computer accidentally be sprayed with water, **1) IMMEDIATELY** turn the Power **OFF** at the Main Power Switch and **2) IMMEDIATELY** contact a qualified service agent to check the computer. The Computer is located in close proximity to hot liquid shortening and care must be taken to avoid serious burns. The floor in front of, and area around the fryer should be kept clean and dry. Whenever anything is put into a cooking vat, care should be taken to not splash the hot shortening. Products should always be “placed” into the shortening, not thrown.
- C. SAFE CLEANING PROCEDURE** - Before performing any cleaning routine, electrical power to the Ultrastat25 cooking computer should be turned OFF at the Main Power Switch. A **SLIGHTLY** dampened cloth may then be used to clean any debris from the face of the computer. **DO NOT USE** any cleaner or de-greaser solvents as they may mar the face or damage the internal circuitry of the computer. Any questions regarding correct cleaning procedures should be directed to the Ultrafryer Customer Service Department at 1-800-525-8130.

II ULTRASTAT25 COOKING COMPUTER

A. COMPUTER CONTROL PANEL

The appearance of the Ultrastat 25 Cooking Computer's control panel may vary slightly depending upon the style of fryer on which the computer is installed:

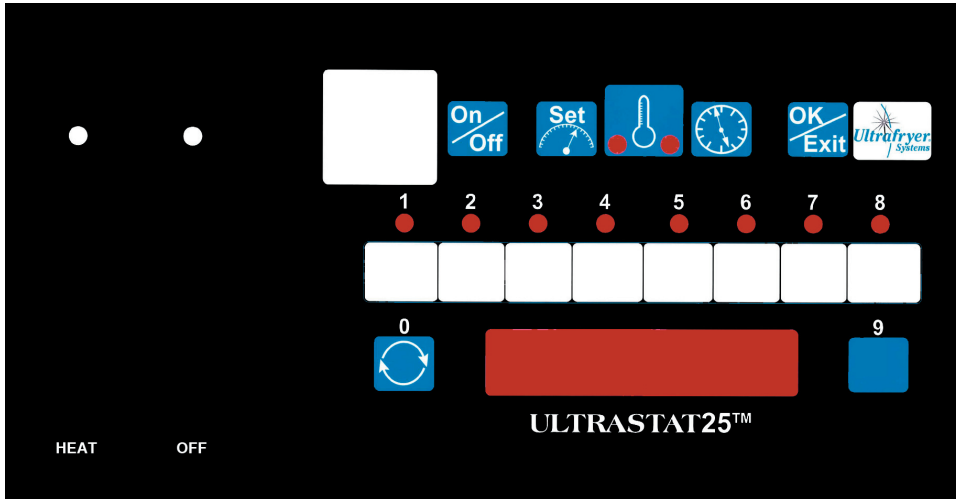

Ultrastat 25 Computer panel on an Ultrafryer-style fryer

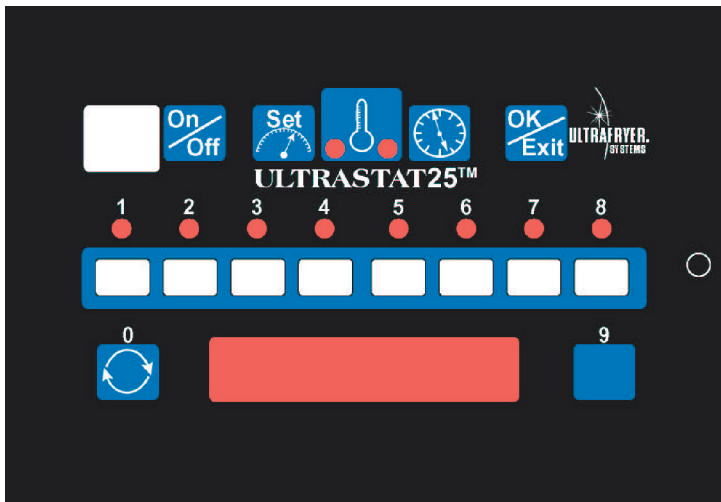

Ultrastat 25 Computer panel on a Cadet-style fryer

Regardless of appearance, the actual operation of the Ultrastat 25 Cooking Computer will be the same in all instances.

B.. COMPUTER FEATURES

1. Programmable Stage Times

The user will have the ability to program certain cook times in each stage of 10 stages in a cook cycle for each product key. The computer is programmable in minutes (up to 59) and seconds (up to 59).

NOTE: Multiple cook starts are not allowed if a product key has more than one stage programmed.

2. Programmable Stage Temperatures

The user will be able to program certain cook temperatures in each stage of a cook cycle for each product key. The valid temperature range is 200 to 390°F (93 to 199°C).

NOTE: The user will be able to program from one (1) to ten (10) stages in a cook cycle for each product key.

3. Programmable Timing Mode

The user will be able to program the timing mode (flex or straight) for each stage of each product key. If a product is configured for flex time, the computer will adjust the actual cook time taking into consideration the temperature variation due to load size, initial product temperature, product moisture content, and other factors affecting the cook cycle, to insure the computer provides consistent, high-quality product. Under straight time mode, the computer will cook only for the specified time without adjusting for these variations.

4. Programmable Action Alarms

The user will be able to program up to three action alarms on each product key. An action alarm is an indication to the operator to perform some action at a pre-programmed time (e.g., STIR FOOD, SHAKE BASKET, etc.).

5. Programmable Temperature Setback

The user will be able to program a temperature setback to take effect whenever a fryer has not been activated for a period of time.

6. Programmable Filtration and Shortening Disposal Prompts

The user will be able to program a filtration and shortening disposal prompt based on the number of product drops. These features may also be turned **OFF** if desired.

7. Melt Cycle

When the computer is ON and the vat temperature is below the Melt Release Temperature, the computer will control the melting of the shortening. In the Melt Mode, the word **MELT E, G, or P**, will appear in the display. After the vat temperature is above the Melt Release Temperature, the user may press the “**OK/EXIT**” key to enter normal cooking mode. Each time the computer is turned **ON**, it will automatically enter the Melt Cycle and must again be overridden by pressing the “**OK/EXIT**” key.

CAUTION: IT IS ABSOLUTELY IMPERATIVE THAT THE USER CHECK TO SEE THAT THE HEAT MECHANISM IS COMPLETELY COVERED WITH “LIQUID” SHORTENING BEFORE PRESSING THE “OK/EXIT” BUTTON. FAILURE TO DO SO COULD RESULT IN PERSONAL INJURY AS WELL AS DAMAGE TO THE FRYER.

*NOTE: If shortening temperature is **ABOVE** the set point programmed for cooking, the computer will automatically override the Melt Mode.*

C. COMPUTER PANEL KEY DESCRIPTIONS

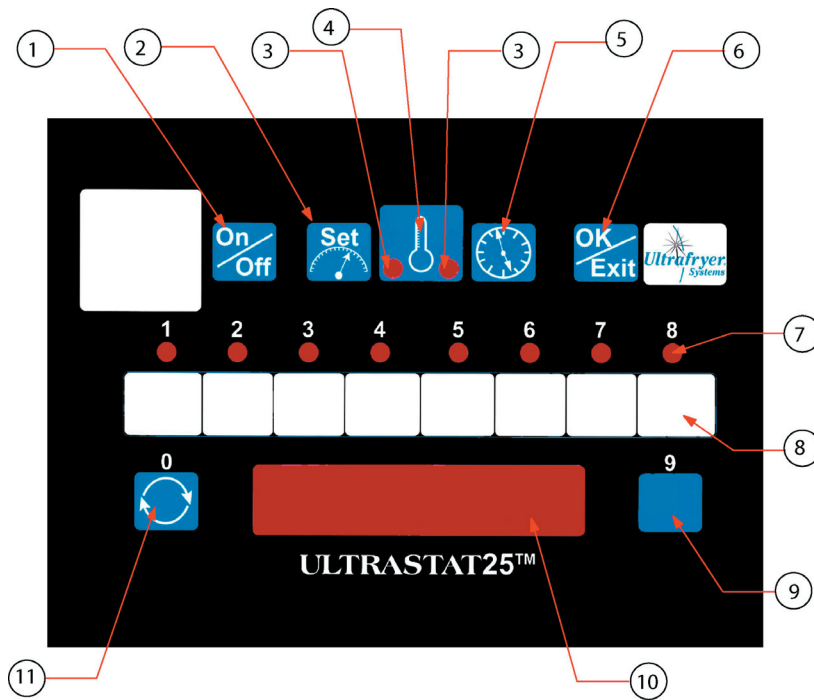

1. ON/OFF KEY

Turns the Computer ON and OFF when the fryer toggle ON/OFF switch is in the **ON** position and the Drain Lever in in the closed **UP** position.

2. SET KEY

- In “operating” mode, allows access to the programming mode.
- In “programming” mode, allows access to the operating mode.

3. HEAT DEMAND LEDS

When lit (bright) indicate the computer is calling for heat.

4. TEMPERATURE KEY

- When depressed one time, displays actual shortening temperature for 3 seconds.
- When depressed two times, within 3 seconds, displays current setpoint temperature for 3 seconds.
- When depressed three times, within 3 seconds, will return to previous display.

5. TIME KEY

Used to display remaining cook time of a product, activate/abort the recipe display of a product, and start the Filter Timer.

6. OK/EXIT KEY

- In “operating” mode used to manually exit the shortening melt cycle, exit the Filter Timer, and activate/exit the setback mode.
- In “programming” mode serves as an ACCEPT key.

7. PRODUCT LED

- When **BLINKING** fast, in “cooking” mode indicates cooking of that product is in process.
- When **BLINKING** slow, indicates cooking of that product is complete.

NOTE: When several products are in the “cooking” mode and the **TIME KEY** is pushed, the Product LED of the first to finish will **BLINK** fast and the other LED’s will **BLINK** slow. When the cook cycle of the “first” product key is complete, its LED will blink **FAST** and the other product key LEDs will turn **OFF**.

- When lit **BRIGHT** in the “programming” mode, indicates that product is being programmed.

8. PRODUCT COOK AND PROGRAMMING KEY

- a. In “operating” mode, used to start and stop a product cook cycle.
- b. In “programming” mode, used to enter numerical values 1 to 8 and to select **RECIPE** or **FEATURES** to be programmed.

9. PROGRAMMING KEY

In “programming” mode, used to enter the numerical value of 9.

10. DISPLAY

Displays modes, functions and operation of the computer.

11. TOGGLE/PROGRAMMING KEY

- a. In “programming” mode, it is used to enter the numerical value of “0” and “toggle” (switch) between **FLEX/STRAIGHT** time modes, **HIGH/LOW** melt release temperature and **CELSIUS/FARENHEIT** temperature units.
- b. In “operating” mode, it can be pushed to display the current **HIT COUNT** and **TIME PROMPT**.



D. DISPLAY DESCRIPTIONS

ACT 100 F/C	—	The actual shortening temperature in degrees Fahrenheit/Celsius when the  key is depressed, ie., 100°F (38°C).
1 0:0 0	—	Time remaining in a cook cycle or other computer function, ie., 10:00.
BOIL 20:00	—	Time remaining in the BOIL mode, ie., 20:00.
OFF	—	Indicates the Computer is ready to be turned ON . NOTE: Computer must be turned OFF by the ON/OFF key before the ON/OFF key can be used to turn the Computer ON .
TURN OFF	—	Prompts operator to push the Computer’s ON/OFF key. Usually occurs when the fryer power switch is turned OFF or drain valve is OPENED .
TOO LOW	—	Indicates an entered value is too low and is NOT ACCEPTABLE .
TOO HIGH	—	Indicates an entered value is too high and is NOT ACCEPTABLE .
SETBACK	—	When optional SETBACK feature is used, indicates the computer has reduced the fryer’s SETPOINT temperature to a LOWER , energy saving, temperature when a product has not been cooked for a programmable length of time.
CK 1-8	—	Indicate the specific Product Key number for which the computer is displaying status information during a cook cycle.
STIR 1-8	—	Indicates an action needs to be taken on a product being cooked by a specific product key such as STIR 5 .
MELT E	—	Electric Melt Cycle - Heating mechanism is ON 4 seconds and OFF 36 seconds.
MELT G	—	Gas Melt Cycle - Heating mechanism is ON 8 seconds and OFF 32 seconds.
MELT P	—	Purge Melt Cycle - Heating mechanism is ON 12 seconds and OFF 28 seconds.

READY	—	The actual shortening temperature is no more than the READY BAND below the (SETPOINT) temperature and no higher than 40°F (22°C) above the set-point temperature. NOTE: The READY BAND is factory set according to the customer's order, usually set at 10°F (5°C) .
LOW	—	The actual shortening temperature is more than the READY BAND below the (SETPOINT) temperature.
HIGH	—	The actual shortening temperature is more than 40°F (22°C) ABOVE the (SETPOINT) temperature.
HIGH TMP	—	The actual shortening temperature is ABOVE 420°F (216°C) . If this occurs the computer will emit a CONTINUOUS ALARM signal.
DONE 1 - 8	—	Indicates a cook cycle has been completed on a product being cooked by a specific product key, such as DONE 5 .
FILTER	—	When FILTER PROMPT is enabled, indicates it is time to filter the shortening because the predetermined quantity of product cooked since last filtering has been exceeded..
DISPOSE	—	When DISPOSAL PROMPT is enabled, indicates it is time to replace the shortening because the predetermined quantity of product cooked with the shortening has been exceeded.
PB OPEN	—	Indicates the computer temperature probe is OPEN . When this occurs; 1) any cook cycle will be CANCELLED ; 2) heating mechanism will be turned OFF and, 3) normal key presses will be INHIBITED .
PB SHORT	—	Indicates the computer temperature probe is SHORTED . When this occurs; 1) any cook cycle will be CANCELLED ; 2) heating mechanism will be turned OFF and, 3) normal key presses will be INHIBITED .
DRAINING	—	Indicates the fryer has electrical power and the Drain Valve has been OPENED to initiate a shortening FILTER or DISPOSAL operation, or the fryer toggle HEAT/OFF switch has been turned OFF to allow operation of the filter pump. This display will alternate with the following displays: DRAINING/FILTER , DRAINING/DISPOSAL OR DRAINING/TURN OFF .

E. OPERATING THE COMPUTER

1. To warm up from OFF:

- a. Press the **ON/OFF KEY**,  the computer will initiate the **SHORTENING MELT MODE** .
- b. When shortening reaches the **SHORTENING RELEASE TEMPERATURE**, press the **OK/EXIT KEY** at which time **LOW** will appear on the display. 
- c. When shortening reaches a temperature in the **READY BAND** around the (SETPOINT) temperature, the Fryer is ready to Cook after the shortening is thoroughly stirred.

2. To run a cook cycle

- Press the Product Key number (**PK #**) for the product;
- At the end of the cook cycle, the alarm will sound and **DONE #** will be displayed.
- Press the Product Key number (**PK #**) to silence the alarm and reset that Product Key.

3. Action Alarms

If the unit is programmed with action alarms, the action alarms will signal at a preset time during the cooking cycle. This signal, a **FAST RATE BEEP**, will last 5 seconds and then self-cancel. **STIR #** will appear in the display indicating the product key # for which product should be stirred.

4. BOIL

CAUTION: PLEASE CONSULT AND FOLLOW THE ENCLOSED GUIDELINES IN SECTION III, E FOR BOILING OF THE FRYER VATS.

The boil function accurately maintains the fryer temperature at 192°F (89°C) to assist the cleaning of fry vats. To start the boil process, turn the appliance **OFF**. Empty the fry vat of shortening. Once the vat is emptied of shortening and refilled with cold water, the computer and fryer may be put into the Boil Mode by turning the Fryer and Computer **ON**.

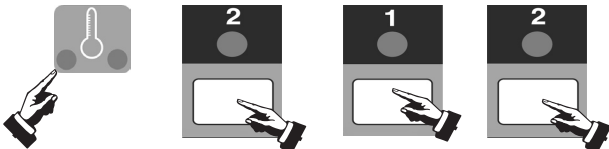
To Enter Boil Mode:  Press the **TEMPERATURE KEY**, followed by the **2, 1, 2** keys.

BOIL will appear in the Display and the fry vat will maintain a temperature of 192°F (89°C) to allow the boil function to be performed.

NOTE: The Fry Vat must be below a temperature of 220°F (104°C) to enter the **Boil Mode**.

To Exit Boil Mode:  Press the **ON/OFF KEY**.

Turn the appliance OFF. The computer will no longer display **BOIL**. Empty the water from the vat, wipe all remaining water from the vat. Once dry, refill the vat with shortening following procedures in paragraph III B 1,

CAUTION: REFILL THE VAT WITH SHORTENING ONLY WHEN IT IS COMPLETELY DRY.

5. FILTER PROMPT

If the unit is programmed for **FILTER PROMPT**, **FILTER** alternating with a normal display will appear after the pre-programmed number of product drops have been exceeded.

III Ultrastat25 COMPUTER OPERATING INSTRUCTIONS

A. TURNING THE Ultrastat25 COMPUTER ON/OFF

To operate the Ultrafryer, the Ultrafryer Toggle HEAT/OFF switch (labeled “COOK/FILTER” on earlier fryer models) must be switched to “HEAT,” and the Computer ON/OFF key must be in the **ON** position.

NOTE: The Ultrafryer Drain Lever must be in the closed **COMPLETELY UP** position to turn the computer **ON**.

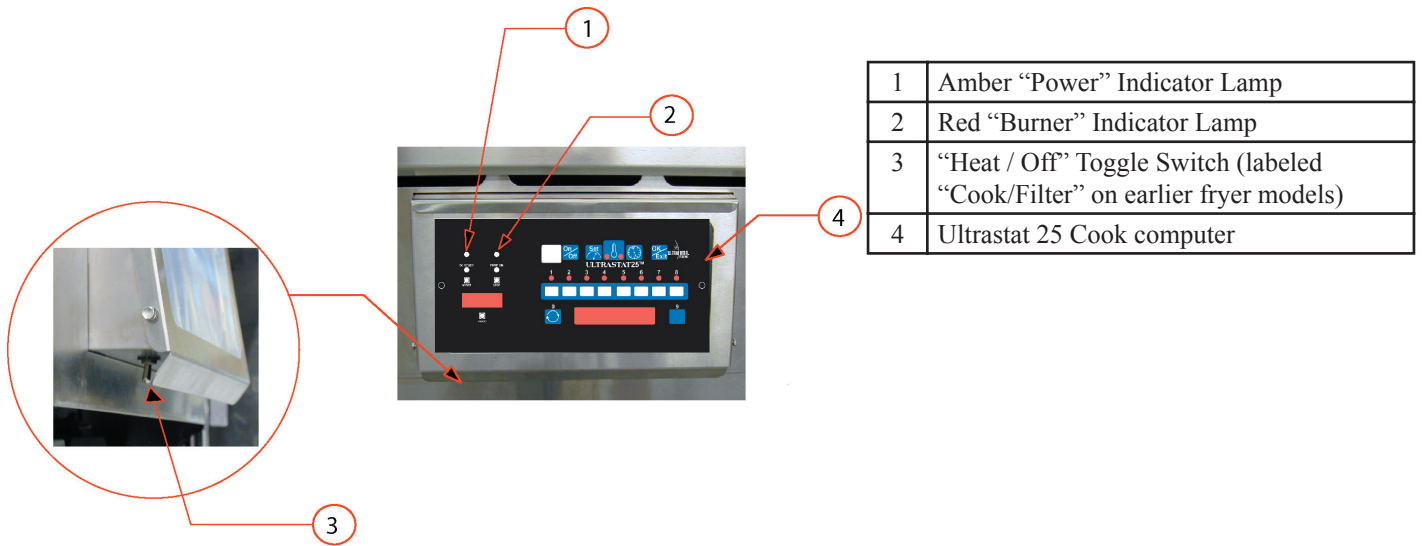

Drain Valve Lever



1. TOGGLE HEAT/OFF SWITCH

NOTE: The “HEAT/OFF” switch is labeled “COOK/FILTER” on earlier fryer models.

- a. The Toggle HEAT/OFF switch is located in the upper left hand corner of the front access panel of the Ultrafryer. When this switch is **OFF**, shortening can be **FILTERED** but the Computer **CANNOT** be turned **ON**. When this switch is on “HEAT”, the Computer can be turned **ON**, but shortening **CANNOT** be filtered.
- b. To turn the Ultrafryer **ON**, turn the Toggle HEAT/OFF switch to the **HEAT** position(if the switch is labeled “COOK/FILTER,” turn the toggle to “COOK”). The **AMBER** Power Indicator Lamp will **LIGHT** and **OFF** will appear in the **DISPLAY** of the Computer.

NOTE: The Ultrafryer heat mechanism cannot be activated when the Computer is **OFF**.

- c. If the fryer is not equipped with a **BUILT-IN** filter system follow procedures in the Fryer’s Operations Manual for filtering shortening.

2. TURNING THE COMPUTER ON :

NOTE: To turn the Computer **ON** the Ultrafryer Toggle HEAT/OFF Switch must be in the **HEAT** position (if the switch is labeled “COOK/FILTER,” it must be in the “COOK” position), and the Drain Lever must be in the **closed / UP** position.

- a. The Computer ON/OFF Key is located in the Upper left corner of the Computer panel.
- b. To turn the Computer **ON**, depress the ON/OFF Key. **MELT E, G, or P** will appear in the computer Display to indicate the computer is in the **SHORTENING MELT MODE**, and the **HEAT DEMAND** lamps on the computer and the **RED INDICATOR** lamp on the fryer will cycle **ON** and **OFF** indicating the heat mechanism is being periodically turned **ON** and **OFF** to gently heat the shortening.

3. TURNING THE COMPUTER OFF :

To turn the Computer **OFF**: turn power on the Ultrafryer **OFF** by turning the Toggle HEAT/OFF switch to the **OFF** position. **DRAINING / TURN OFF** will appear in the display; then push the Computer ON/OFF key to turn the Computer **OFF**.

NOTE: When the Computer is **OFF**, the Heat Mechanism **CANNOT** be activated.

B. MELTING SHORTENING

Each time the Computer is turned **ON**, it will enter the **SHORTENING MELT MODE**. This mode is used to “gently” melt **SOLID** shortening in a vat after **BOIL-OUT** as well as **CONGEALED** shortening in a vat prior to store opening. While the Computer is in this mode it will periodically turn the Ultrafryer Heat Mechanism **ON** and **OFF** to gradually warm the shortening.

NOTES: 1) The Computer will keep the Ultrafryer in the **MELT CYCLE** until the operator **MANUALLY** pushes the **OK/EXIT** key. 2) The Computer **CANNOT** be taken out of the **SHORTENING MELT MODE** until shortening temperature reaches the **MELT RELEASE TEMPERATURE**. The Melt Release Temperature is factory set for a **HIGH** exit temperature (135°F (57°C)) or a **LOW** exit temperature (75°F (24°C)) according to the customer’s specifications. Once the Melt Release Temperature is reached the Melt Mode may be canceled by pushing the **OK/EXIT** key. 3) The following **MELT CYCLE OPTIONS**, which determine the amount of time the **HEAT MECHANISM** is turned **ON** and **OFF** to melt shortening, can be programmed based on the type of fryer equipped with an Ultrastat 25 Cooking Computer.

TYPE FRYER

MELT CYCLE OPTION

Ultrafryer Model EU
ZRT Express or ZRT Counter Top Electric
Fryer

E - Heat Elements are turned **ON** for **FOUR (4)** seconds and **OFF** for 36 seconds.

Ultrafryer Model PAR-2 Gas Fryer

G - Burners are turned **ON** for **EIGHT (8)** seconds and **OFF** for **32** seconds

Ultrafryer Model PAR-3 ZRT Express or ZRT
Counter Top Gas Fryer

P - Burners are turned **ON** for **12** seconds and **OFF** for **28** seconds.

WARNING: DO NOT PUSH THE “OK/EXIT” KEY UNTIL THE VAT IS CHECKED TO ASSURE THE HEAT MECHANISM IS “COMPLETELY” COVERED WITH LIQUID SHORTENING.

1. **MELTING SOLID SHORTENING** - The preferred method of heating solid shortening in a computer equipped fryer is as follows:
 - a. Cut a block of solid shortening into small pieces.
 - b. Place small pieces of shortening **EVENLY** on top of the Heat Mechanism or **THOROUGHLY** pack these pieces of solid shortening between, below and above the HEAT MECHANISM. While packing solid shortening is messy and time consuming, it is the fastest way to melt solid shortening.
 - c. Turn the Ultrafryer Toggle HEAT/OFF Switch to **HEAT**; then place the Computer in the **SHORTENING MELT MODE** by depressing the ON/OFF key. **MELT E, G, or P** will appear in the computer display, indicating the Computer is in the **SHORTENING MELT MODE**; and the **HEAT DEMAND LEDs** on the computer and the fryer’s **RED INDICATOR LAMP** will cycle ON and OFF indicating the heat mechanism is periodically being turned **ON** and **OFF** to heat the shortening gradually.
 - d. When the heat mechanism is **COMPLETELY** covered with **LIQUID** shortening and the shortening is **ABOVE** the Melt Release Temperature, replace the grill in the fryer vat; then push the **OK/EXIT** key on the Computer.

WARNING: DUE TO THE LOCATION OF THE COMPUTER’S TEMPERATURE PROBE, IT IS POSSIBLE FOR THE SHORTENING LEVEL TO BE ABOVE THE PROBE WITHOUT COVERING THE HEAT MECHANISM. THEREFORE, VISUALLY CONFIRM THAT LIQUID SHORTENING IS AT LEAST TWO (2) INCHES ABOVE THE HEAT MECHANISM BEFORE PRESSING THE OK/EXIT KEY.

- e. Continue adding solid shortening as follows:
 - 1) Place small pieces of solid shortening into a fry basket.
 - 2) **CAREFULLY** lower the basket into the fryer vat.
 - 3) **GENTLY** turn the basket to allow these pieces of solid shortening to float away.
 - 4) Repeat the above steps until liquid shortening is even with the middle line of the “**E ←**” in the word **LEVEL** of the applicable shortening level mark on the rear wall of the fryer vat.

2. WARMING CONGEALED SHORTENING

Each morning when the Ultrafryer and Computer are first turned **ON**, the Computer will be in the **SHORTENING MELT MODE** and the Ultrafryer Heat Mechanism will be turned **ON** and **OFF** to warm congealed shortening gradually to the **MELT RELEASE TEMPERATURE**. When liquid shortening temperature rises to the Melt Release Temperature, the operator can push the **OK/EXIT** key to heat shortening to its **SETPOINT** temperature, provided shortening is 2” (52 mm) over the Heat Mechanism.

C. OPERATING THE COMPUTER

1. COOKING FEATURES

a. PROGRAMMED STAGED TIMES/TEMPERATURES

Some Computers will be pre-programmed with a **STAGED COOK CYCLE** for cooking chicken. When a Computer is in a **STAGED COOK CYCLE** it controls the Ultrafryer so shortening is heated to a **CERTAIN TEMPERATURE** at a **CERTAIN TIME** in the cook cycle. For example a product key could be programmed as follows for cooking Chicken:

NOTE: These times and temperatures are examples **ONLY** and **ARE NOT USED BY ANY KNOWN COMMERCIAL RESTAURANT**.

SETTING	TIME	TEMPERATURE
1	14:00	330°F / 166°C
2	13:55	305°F / 152°C
3	6:00	310°F / 154°C
4	4:00	320°F / 160°C
5	2:00	330°F / 166°C

The **SETPOINT** temperature of that product key is 330°F (166°C). When product is dropped the shortening temperature will **DROP** and the Computer will control the fryer to maintain shortening temperature at 305°F (152°C) for about **7 MINUTES** (13:55 to 6:00 in the cook cycle). At the end of **8 MINUTES**, the Computer will control the fryer to increase shortening temperature to 310°F (154°C) for **2 MINUTES** (8:00 to 10:00 in the cook cycle). At the end of **10 MINUTES**, the Computer will control the fryer to increase shortening temperature to 320°F (160°C) for **2 MINUTES** (10:00 to 12:00 in the cook cycle). For the last 2 minutes (12:00 to 14:00) in the cook cycle, the Computer will control the fryer to increase and maintain the shortening temperature at 330°F / 166°C.

NOTE: Multiple products **CANNOT** be simultaneously cooked if a **STAGED COOK CYCLE** is being used because a staged cook cycle requires a fryer to be at a **CERTAIN TEMPERATURE** at a **CERTAIN TIME** in the cook cycle.

b. MULTIPLE COOK TEMPERATURES

Computers can be programmed with **COOK CYCLES** that require different shortening temperatures for different products cooked in a fryer vat. For example, **PRODUCT KEY 1** could have a **SETPOINT** temperature of **330°F (166°C)** and **PRODUCT KEYS 2, 3 AND 4** could have a **SETPOINT** temperature of **350°F (177°C)**.

NOTE: When the Ultrafryer and Computer are first turned **ON**, shortening in that fryer vat will be heated to the **LOWEST SETPOINT** temperature (330°F / 166°C). If a product requires the **HIGHER SETPOINT** temperature, press the Product Key for that product.

c. FLEX/STRAIGHT TIME MODE

Some Computers are pre-programmed for the **FLEX** time mode and others are set for the **STRAIGHT** time mode. The **FLEX** time mode automatically adjusts the **COOK TIME** taking into consideration: 1) shortening temperature drop when the product is placed into the shortening, 2) initial product temperature, 3) product moisture content and 4) other factors affecting the cook cycle to insure a consistently high quality product is cooked. In **FLEX** time the computer displays “**FLEX**” time rather than “**STRAIGHT**” time. In the **STRAIGHT** time mode, a product is cooked for the amount of time for which the Computer has been programmed without any variation of time.

NOTE: When **FLEX TIME MODE** is being used the **TIME** being displayed will appear as if it were **REAL TIME** elapsing, but this time is running **SLOWER** or **FASTER** than real time depending on whether the **ACTUAL** temperature is below or above the setpoint temperature.

d. FILTER PROMPT

A computer can be programmed for a visual **FILTER PROMPT** after a pre-determined amount of product has been cooked, or a predetermined amount of time has passed to alert the operator it is time to filter the shortening. If this feature is used, **FILTER** will appear in the display alternating with a normal display, after the programmed amount of product has been cooked.

e. DISPOSAL PROMPT

A computer can be programmed for a visual **DISPOSAL PROMPT** after a pre-determined amount of product has been cooked, to alert the operator it is time to dispose of the shortening. If this feature is used, **DISPOSE** will appear in the display alternating with a normal display, after the programmed amount of product has been cooked.

f. TEMPERATURE SETBACK

A computer can be programmed to automatically reduce the **SETPOINT TEMPERATURE** of a fryer to a **LOWER**, energy saving, temperature when a product has not been cooked in that fryer for a pre-determined length of time. If this feature is used, **SETBACK** will appear in the display to alert the operator that shortening temperature in the fryer is being reduced.

2. COOKING

When the Computer is taken out of the **SHORTENING MELT MODE** each morning, shortening in the fryer vat will be heated to its **SETPOINT** temperature and “**LOW**” will appear in the display to indicate the shortening temperature is **MORE** than the **READY BAND** temperature **BELOW** the setpoint temperature. When shortening temperature rises to the **SETPOINT** temperature **READY** will appear in the display indicating a **COOK CYCLE** can be started.

a. STARTING A COOK CYCLE

To start a cook cycle, simply press the product key is programmed, the Product cooking time will be displayed,

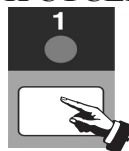

start to count down in minutes and seconds. If correctly programmed, the computer will count down to **00 : 00** , the alarm will **SOUND** and **DONE 1** will appear in the display. Press Product Key 1 to silence the alarm and reset that product key for another cook cycle.

the product key you wish to cook. If the product Key **LED** will **BLINK FAST** and **CK 1** and correct (example, **14:00**) and this time will immediately

start to count down in minutes and seconds. If correctly programmed, the computer will count down to **00 : 00** , the alarm will **SOUND** and **DONE 1** will appear in the display. Press Product Key 1 to silence the alarm and reset that product key for another cook cycle.

b. CANCELLING A COOK CYCLE

If a cook cycle was inadvertently started

- 1) Press and hold the same product key
This prevents an accidental cancelling
- 2) A cook cycle can be **CANCELLED** at any time by turning the Ultrafryer Toggle **HEAT/OFF SWITCH** to the **OFF** position.

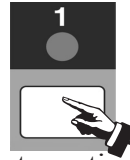

it may be cancelled two (2) ways:
used to start the cook cycle for **4 SECONDS**.
of a cook cycle while a product is being cooked.

c. ACTION ALARMS

Some Computers are pre-programmed for **ACTION ALARMS** when cooking certain products to alert the operator it is time to take some action such as stirring the product. When this feature is used; the Computer will alert the operator with a **RAPID BEEPING** that will last for **5 SECONDS** then self-cancel, and **STIR** will appear in the display and continue counting towards the next action alarm time. For example, a product key could be programmed with three (3) action alarms:

<u>PRE-ALARM</u>	<u>TIME</u>	<u>OCCURRENCE TIME IN A 14 MINUTE COOK CYCLE</u>
1	9:00	5:00
2	6:00	8:00
3	3:00	11:00

The first action alarm would be signaled when the Computer counts down to 9:00 (5 minutes after start of the cook cycle), the second alarm would be signaled when the Computer counts down to 6:00 (8 minutes into the cook cycle), and the last signal would occur when 3 minutes is left in the cook cycle (11 minutes into the cook cycle).

3. FRYER VAT BOIL-OUT

a. **BOIL-OUT** each fryer following cleaning instructions contained in the Cleaning Manual provided by your approved chemical supplier. The following are generic procedures:

- 1) Ensure all Drain Levers are in the closed (**UP**) position, then add water to each vat until it reaches a point two (2) inches **BELOW** the middle line of the “**E ←**” in the word **LEVEL** of the **UPPER** shortening level mark on the rear wall of the vats.

WARNING: ONLY USE A COMMERCIAL GRADE “NON-CHLORINE” BOIL-OUT COMPOUND!!

- 2) Add the amount of **BOIL-OUT COMPOUND** in each fryer vat prescribed in the Cleaning Manual provided by the Chemical Supplier.
- 3) Turn the Toggle **HEAT/OFF** switch to **HEAT** (or to “**COOK**” if the switch is labeled “**COOK/FILTER**”) and, if applicable, the Manual Gas valve for each fryer vat to the **ON** position; then depress the Computer **ON/OFF** Key to the **ON** position.

NOTE: The Drain Lever must be in the closed **UP** position to turn the computer **ON**.

- 4) Place the Computer in the **BOIL MODE** by pressing the following Computer keys in the order shown:

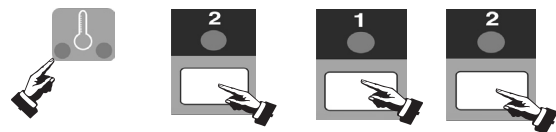

NOTE: **BOIL 30:00** will appear in the Computer display and the Computer will turn the Ultrafryer **ON** and **OFF** to heat and maintain the boil-out solution at 192°F (89°C).

- 5) Frequently scrub the sides, front and rear of each fryer vat with a long handled synthetic bristle scrub brush.
- 6) After the boil-out solution has “**BOILED**” for 30 minutes and the alarm sounds, press the



key to **EXIT BOIL MODE**.

- 7) Turn the Toggle HEAT/OFF Switch and if applicable, the Manual Gas Valve for each fryer to their **OFF** positions (or to “FILTER” if the switch is labeled “COOK/FILTER”) and **CAREFULLY** dispose of the boil-out solution in each fryer in a floor drain.

NOTE: Do not use the filter pump to remove water from the vats as this will cause premature pump failure and void the pump warranty.

- 8) Use a scrubbing pad to remove carbon buildup from the top of the heat mechanism. To remove carbon buildup on the sides and bottom of the heat mechanism; slide one end of a stropping pad under each heat mechanism, grasp that end with a pair of tongs, and rock the pad up and down along the length of each heat mechanism until all encrusted material has been removed.
- 9) Rinse each fryer with hot water until the water coming out of the drain valve is clear.
- 10) Mix a solution of **ONE PART** vinegar to **25 PARTS** of water. Place this mixture into a one gallon garden pressure sprayer; and **THOROUGHLY** spray this solution onto the **SIDES**, **HEAT MECHANISM**, and **BOTTOM** of each fryer to neutralize the Boil-Out Compound.

NOTE: Boil-Out Compound will cause shortening to break down rapidly if it is not neutralized.

- 11) **THOROUGHLY** wipe the sides, heat mechanism, and bottom of each fryer with clean, lint-free, dry towels to remove any remaining water; then fill each fryer with **NEW** shortening following procedures in Paragraph III B of this manual.

IV ULTRASTAT COMPUTER SETTINGS AND PROGRAMMING

The Ultrastat25 Cooking Computer has two (2) modes of operation:

OPERATING MODE - Pre-programmed cook times and temperature for standard products plus action alarms.

PRODUCT PROGRAMMING MODE - Allows customers to add, delete or modify product **RECIPES** or **FEATURES**. Recipe programming pertains to staged cook times, temperatures and action alarms of products; Feature programming pertains to selecting celsius/fahrenheit, computer setback of time and temperature, melt cycle options, filtering prompts, and shortening disposal prompts.

CAUTION: DUE TO THE COMPLEXITY OF AN ULTRASTAT25 COMPUTER, PROGRAMS SHOULD ONLY BE CHANGED BY AN AUTHORIZED OPERATIONS MANAGER/SUPERVISOR OR A SERVICE AGENT APPROVED BY ULTRAFRYER SYSTEMS' CUSTOMER SERVICE DEPARTMENT.

A. PROGRAM DISPLAYS

1. RECIPE PROGRAM DISPLAYS

- PROGRAM** — Indicates computer is in the program mode and allows the customer to select **RECIPE** programming by entering **3660** (cook password) or **FEATURE** programming by entering **3661** (feature password).
- RECIPE** — Indicates computer is in the Recipe programming mode in which product staged cook times and temperatures, and action alarms may be programmed
- TOO HIGH** — Indicates the number of steps, time, temperature, or action alarms entered is too high and is **NOT ACCEPTABLE**.
- TOO LOW** — Indicates the number of steps, time, temperature, or action alarms entered is too low and is **NOT ACCEPTABLE**.
- STRAIGHT** — Indicates “straight” cook time has been selected where the product is cooked at a certain temperature for a certain time.
- FLEX** — Indicates “flex” cook time has been selected where the computer adjusts the actual cook time taking into consideration the temperature variations due to load size, initial product temperature, product moisture content, and other factors affecting the cook cycle.
- ALARMS** — Indicates the number of **STIR** alarms that may be programmed for this Product Key.
- HITS** — Indicates shortening abuse weight factor of the Product Key being programmed.

NOTE: A “programming timeout” will occur if no key is pressed for **TWO (2)** minutes and the computer will return to normal operations.

2. FEATURE PROGRAM DISPLAYS

PROGRAM — Indicates computer is in the program mode and allows the customer to select **RECIPE** programming by entering **3660** (cook password) or **FEATURE** programming by entering **3661** (feature password).

FEATURE — Indicates computer is in the Feature programming mode in which the customer is able to select either: 1) Celsius or Fahrenheit temperature unit; 2) Alarm (Beeper) volume; 3) Setback time / temperature; 4) Melt Option; 5) Filter prompt; and 6) Disposal prompt.

TOO HIGH — Indicates an entered value is too high and is **NOT ACCEPTABLE**.

TOO LOW — Indicates an entered value is too low and is **NOT ACCEPTABLE**.

SETB 00:00 — Prompt to enter the **SETBACK** time in hours and minutes.

SETB000F/C — Prompt to enter the **SETBACK** temperature in degrees fahrenheit or celsius.

G — Melt option for a gas fryer (Gas cycles **ON** for 8 seconds and **OFF** 32 seconds)

E — Melt option for a electric fryer (Heat element **ON** for 4 seconds and **OFF** 36 seconds)

P — Melt option for purge where the purge cycle is **ON** for 12 seconds and **OFF** 28 seconds

M REL HI — Prompt to select the **HIGH** (135°F (57°C)) Melt Release temperature.

M REL LO — Prompt to select the **LOW** (75°F (24°C)) Melt Release temperature.

FHCL ### — Prompt to enter the shortening **FILTER HIT COUNT LIMIT** for the filter prompt.

FHCS ### — Indicates the current **FILTER HIT COUNT** (weighted cooks since last Filtering).

TIME — Indicates the elapsed time in **HOURS** of operation to start of the Filter Prompt.
Setting it to  will disable the Time Prompt.

LAST/PREV/FCTY— Indicates View Recovery Test options between **LAST**, **PREVIOUS**, and **FACTORY** recovery times. While viewing **FACTORY** a new 3 digit second value may be entered.

DHL ##### — Prompt to enter the shortening **DISPOSAL HIT COUNT LIMIT** for the disposal prompt.

DHC ##### — Indicates the current **DISPOSAL HIT COUNT**.

NOTE: HIT refers to the shortening abuse associated with cooking a quantity of a product. The hits are programmed to each product key and added to the Filter Hit Count each time the product is cooked.

B. ULTRASTAT 25 COMPUTER PROGRAMMING

1. PROGRAMMING FLOW CHART

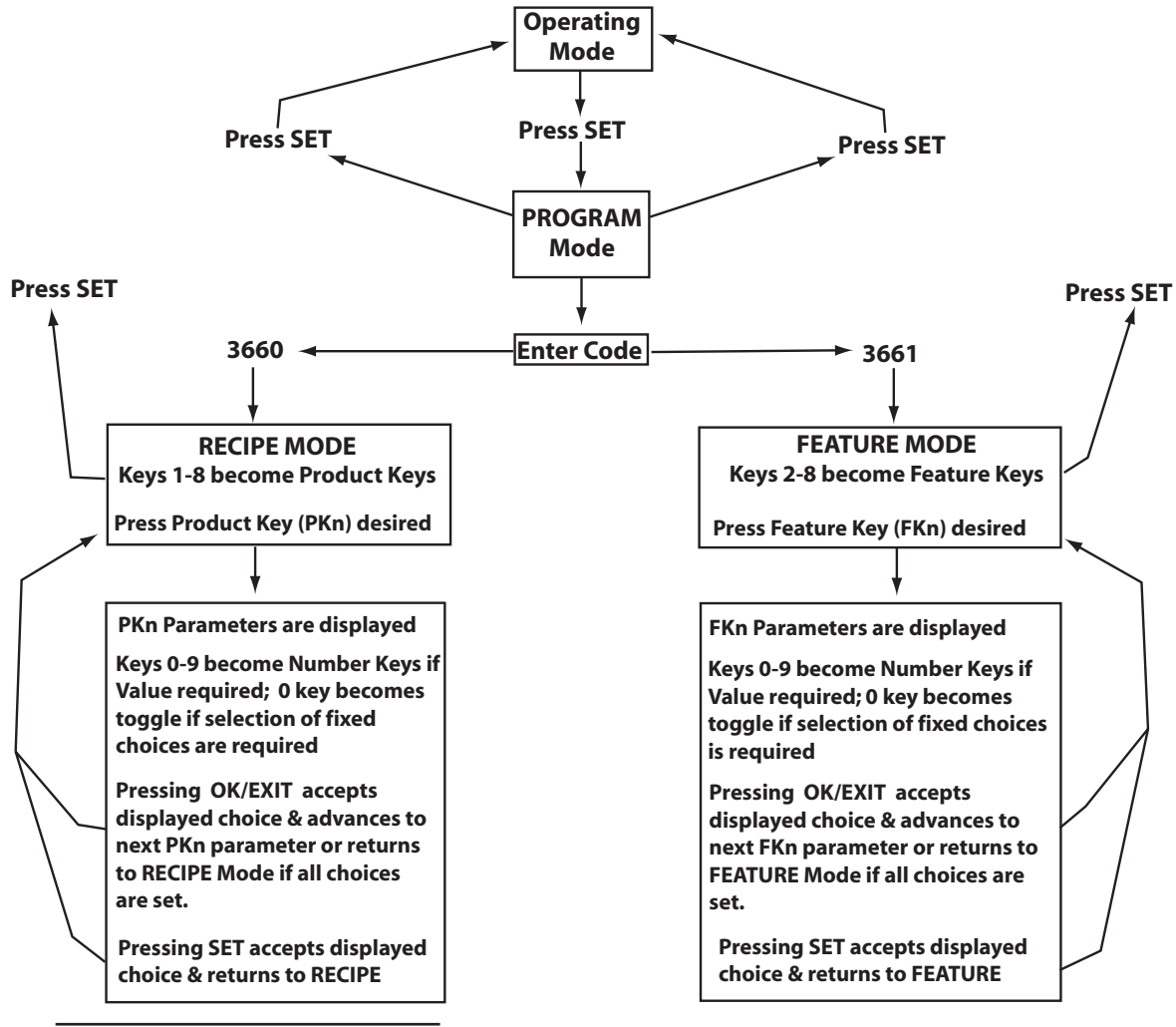

RECIPE Parameters

No. of Steps
 (For each step)
 TIME
 TIME CURVE
 TEMPERATURE

No. of ALARMS
 (For each alarm)
 TIME
 HITS



FEATURE List

FK2 -- Degrees (F or C)
 FK3 -- Alarm Volume (1,2,or 3)
 FK4 -- SETBACK (TIME, TEMP)
 FK5 -- MELT (E, G, or P)
 Release temp (LO or HI)
 FK6 -- Recovery Data
 LAST; PREV; FCTY
 FK7 -- FILTER Prompt
 HIT LIMIT; HITS; TIME Cue
 FK8 -- DISPOSE Prompt
 HIT LIMIT; HITS

- To program product cook times, temperatures, and action alarms, proceed to paragraph 3, **RECIPE PROGRAMMING**. To program Celsius/Fahrenheit temperature unit, computer setback time and temperature, melt cycle options, and filtering/disposal prompts proceed to paragraph 4, **FEATURE PROGRAMMING**.

NOTES: 1. The following steps pertain to programming one (1) Product Key for a gas fryer.
 2. A PROGRAMMING TIMEOUT will occur if no keys are pressed for two (2) minutes in the programming mode.

3. RECIPE PROGRAMMING:

<u>STEP</u>	<u>ACTION</u>	<u>RESPONSE</u>
1	<p>ENSURE the Drain Lever on the fryer is in the CLOSED position, shortening is at the proper level, the TOGGLE HEAT/OFF SWITCH is ON; the AMBER power indicator lamp is LIT; then depress the computer ON/OFF key.</p>	<p>A. MELT E, G, or P will appear in the display to indicate the computer is in the SHORTENING MELT MODE.</p> <p>B. The HEAT DEMAND lamp on the computer and the RED HEAT INDICATOR lamp on the fryer will cycle ON and OFF indicating the heat mechanism is periodically being turned ON and OFF to heat the shortening gradually.</p>
2	<p>Depress the SET key to enter the PROGRAMMING MODE.</p>	<p>A. PROGRAM will appear in the display to indicate the computer is in the program mode.</p>
3	<p>Enter the COOK PASSWORD “3660” to enter product key programming.</p>	<p>A. RECIPE will appear in the display to indicate product keys may be programmed.</p> <p>B. All Product Key LEDs will LIGHT.</p>
4	<p>Depress the PRODUCT KEY to be programmed, ie., PK 1.</p>	<p>A. Product Key 1 LED will LIGHT indicating it is ready to be programmed.</p> <p>B. Product Key 2 through 8 LEDs will be OFF.</p> <p>C. Prompt 00 STEPS will appear in the display indicating the number of cooking steps to be programmed for this product key.</p>
5	<p>Enter the number of cooking steps to be programmed, (example 05); then depress the OK/EXIT key for this number to be accepted.</p> <p>NOTE: Maximum number of steps to be accepted is 10. “TOO HIGH” will appear in the display if more than 10 steps is entered.</p>	<p>A. Prompt S1 00:00 will appear in the display indicating the time for step 1 to begin is to be entered.</p>
6	<p>A. Enter the TIME STEP 1 is to begin, (referenced to the end of a cook cycle); then press the OK/EXIT key for the time to be accepted, i.e.; STEP 1 13:00.</p> <p>B. Depress the  Key to toggle between STRAIGHT  or FLEX Timing Mode; then depress the OK/EXIT Key for this selection to be accepted, i.e.; STEP 1 FLEX</p> <p>C. Enter the TEMPERATURE for STEP 1; then depress the OK/EXIT Key for this temperature to be accepted, i.e.; STEP 1 330°F/166°C</p> <p>NOTE: If 00:00 is entered, programming for this PRODUCT KEY is ended.</p> <p>D. Repeat Steps 6A, 6B, and 6C to program the START TIME, TIMING MODE, and TEMPERATURE for subsequent STEP 2, STEP 3, STEP 4, and STEP 5.</p> <p>NOTES: 1) If 00:00 is entered for a subsequent STEP, NO OTHER STEP CAN BE PROGRAMMED. 2) Entry MUST BE between 200 and 390°F (93 to 199°C). 3) TOO HIGH will be displayed if entry is greater than 390°F (199°C). 4) TOO LOW will be displayed if entry is less than 200°F (93°C). 5) Repeated presses of the OK/EXIT key will scroll through time, straight/flex and temperature for each step until the last step is completed.</p>	<p>A. Prompt STRAIGHT/FLEX will appear in the display indicating the Type Timing Mode is to be selected.</p> <p>B. Prompt S01 000F will appear in the display indicating the Temperature in °F for STEP 1 is to be entered.</p> <p>C. Prompt S2 00:00 will appear in the display indicating START TIME, TIMING MODE and TEMPERATURE for STEP 2 is to be entered.</p> <p>D. After the TEMPERATURE for the last STEP (STEP 5) has been entered and accepted, prompt ALARMS will appear in the display indicating the number of alarms desired is to be entered.</p>





3. RECIPE PROGRAMMING ... continued:

<u>STEP</u>	<u>ACTION</u>	<u>RESPONSE</u>												
7	Enter the number of stir alarms desired; for example 3 ; then depress the OK/EXIT key for this number to be accepted. NOTE: Maximum number of alarms is 3 . TOO HIGH will be displayed if a higher number is entered.	A. Prompt Am 00:00 will be displayed indicating the time for each alarm signal is to be entered.												
8	Enter the TIME each alarm is to begin, referenced to the end of the cook cycle; then press the OK/EXIT key after each entry. For example: <table border="0" style="margin-left: auto; margin-right: auto;"> <thead> <tr> <th style="text-align: left;"><u>ALARM</u></th> <th style="text-align: left;"><u>TIME</u></th> <th style="text-align: left;"><u>OCCURENCE TIME IN COOK CYCLE</u></th> </tr> </thead> <tbody> <tr> <td>1</td> <td>9:00</td> <td>4:00</td> </tr> <tr> <td>2</td> <td>6:00</td> <td>7:00</td> </tr> <tr> <td>3</td> <td>3:00</td> <td>10:00</td> </tr> </tbody> </table> NOTE: Each time entered must be a minimum of 10 seconds less than the previous entry.	<u>ALARM</u>	<u>TIME</u>	<u>OCCURENCE TIME IN COOK CYCLE</u>	1	9:00	4:00	2	6:00	7:00	3	3:00	10:00	A. Prompt HITS ## will be displayed indicating the HIT COUNT VALUE for the FILTER PROMPT and DISPOSAL PROMPT may be entered. NOTE: HIT COUNT VALUE EQUALS SHORTENING ABUSE ASSOCIATED WITH THE PRODUCT DROP.
<u>ALARM</u>	<u>TIME</u>	<u>OCCURENCE TIME IN COOK CYCLE</u>												
1	9:00	4:00												
2	6:00	7:00												
3	3:00	10:00												
9	Enter the HIT COUNT VALUE (PRODUCT DROP) equivalent to the product being programmed; then depress the OK/EXIT key for the number to be accepted. For example: <table border="0" style="margin-left: auto; margin-right: auto;"> <thead> <tr> <th style="text-align: left;"><u>PRODUCT</u></th> <th style="text-align: left;"><u>ENTER</u></th> </tr> </thead> <tbody> <tr> <td>CHICKEN</td> <td>5</td> </tr> <tr> <td>FRENCH FRIES</td> <td>1</td> </tr> <tr> <td>FILLETS</td> <td>2</td> </tr> </tbody> </table> NOTE: Hit Count Value (product drop) equals the measure of abuse shortening gets with the cook of a product using this Product Key. The measure of abuse is then associated with the Hit Count Limit stored in the Filter Prompt and Disposal Prompt Features. Any convient unit may be defined as long as the same unit is used on each Product Key as well as the Filter and Disposal Prompts. A convient unit might be the cooking of 1 POUND of unbattered french fries; then a HIT COUNT of 1 would be entered for a Product Key meant to cook 1 pound of unbattered french fries in a basket. If a chef/manager determined a pound of battered fillets (5 pieces) caused TWICE as much abuse as unbattered french fries; then a HITCOUNT of 2 would be entered for a Product Key meant to cook a pound (5 pieces) of battered fillets. Likewise, 48 pieces of battered chicken may cause 5 times the abuse as unbattered french fries, so a HITCOUNT of 5 would be entered for a Product Key meant to cook 48 pieces of battered chicken.	<u>PRODUCT</u>	<u>ENTER</u>	CHICKEN	5	FRENCH FRIES	1	FILLETS	2	A. RECIPE will appear in the display indicating another product may be programmed according to steps 4 through 9. B. Press the next PRODUCT KEY to be programmed, ie., PK 2 , and program this product key according to steps 4 through 9. C. When all product keys have been programmed and RECIPE appears in the display, press the SET key “twice” to exit the Recipe programming mode. READY will appear in the display.				
<u>PRODUCT</u>	<u>ENTER</u>													
CHICKEN	5													
FRENCH FRIES	1													
FILLETS	2													

4. FEATURE PROGRAMMING:

<u>STEP</u>	<u>ACTION</u>	<u>RESPONSE</u>									
1	Depress the SET key to enter the programming mode.	A. PROGRAM will appear in the display to indicate the computer is in the program mode.									
2	Enter the FEATURE PASSWORD “3661” to enter Feature key programming.	A. FEATURE will appear in the display to indicate Feature key may be programmed. B. All Feature Key LED’S will LIGHT .									
3	Depress the FEATURE KEY to be programmed, ie., FK 2 .	A. All Feature Key LED’S will turn OFF .									
4	Depress Feature Key “ 2 ” ; then depress the  key to toggle between the CELSIUS and FAHRENHEIT temperature units. Press the OK/EXIT key for this selection to be accepted.	A. DEGREE C/F will be displayed to indicate the temperature unit selected. B. When OK/EXIT key is pressed, FEATURE will appear in the in the display.									
5	Depress Feature Key “ 3 ” ; then depress the  key to toggle between BEEPER volumes. Press the OK/EXIT key for this selection to be accepted.	A. VOLUME 3 will be displayed to indicate this volume has been selected. B. When OK/EXIT key is pressed, FEATURE will appear in the in the display.									
6	Depress the Feature Key “ 4 ” to program the SETBACK TIME/TEMPERATURE desired.	A. Prompt SETB 00:00 will appear in the display indicating the TIME period of INACTIVITY before the Setback Mode is entered.									
7	Enter the time period of INACTIVITY before the Setback Mode is automatically activated. For example: 02:00 for two (2) hours. Press the OK/EXIT key for this time to be accepted. NOTE: Setback can be initiated by QUICKLY pressing the TEMPERATURE followed by the OK/EXIT keys.	A. SETB 02:00 will be displayed indicating this entry has been accepted. B. Prompt SETB 000F/C will be displayed indicating the amount the SETPOINT TEMPERATURE is to be reduced is to be entered.									
8	Enter the number of degrees below the SETPOINT TEMPERATURE shortening is to be reduced at the end of the SETBACK TIME . Press the OK/EXIT key for this entry to be accepted. For example: <table border="0" style="margin-left: auto; margin-right: auto;"> <tr> <td colspan="3" style="text-align: center;">SHORTENING TEMPERATURE</td> </tr> <tr> <td style="text-align: center;">SETPOINT</td> <td style="text-align: center;">REDUCED</td> <td style="text-align: center;">ENTER</td> </tr> <tr> <td style="text-align: center;">330°F (166°C)</td> <td style="text-align: center;">250°F (121°C)</td> <td style="text-align: center;">80°F (27°C)</td> </tr> </table> NOTE: Maximum value that will be accepted is 150°F (66°C) .	SHORTENING TEMPERATURE			SETPOINT	REDUCED	ENTER	330°F (166°C)	250°F (121°C)	80°F (27°C)	A. SETB 80°F (27°C) will be displayed indicating the SETBACK TEMPERATURE SETPOINT will be reduced during SETBACK mode activation. B. When OK/EXIT key is pressed, FEATURE will appear in the display.
SHORTENING TEMPERATURE											
SETPOINT	REDUCED	ENTER									
330°F (166°C)	250°F (121°C)	80°F (27°C)									
9	Depress the Feature Key “ 5 ” then depress the  key to toggle between the MELT OPTIONS . For example: “ G ” for gas, “ E ” for electric, or “ P ” for purge. Depress the OK/EXIT key for this entry to be accepted. NOTE: The Gas Cycle will be ON 8 seconds and OFF 32 seconds, the Purge Cycle will be ON 12 seconds and OFF 28 seconds and the Electric Cycle will be ON for 4 seconds and OFF for 36 seconds.	A. M REL HI or M REL LO will appear in the display indicating the MELT RELEASE setting may now be selected.									
NOTE: ZRT Express and Counter Top and Model PAR-3 Gas Fryers are to be set for P - PURGE, all other Gas Fryers are set for G - GAS.											

4. FEATURE PROGRAMMING continued :

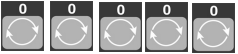
STEP	ACTION	RESPONSE						
10	Press the  key to toggle between the REL HI (135°F (57°C)) and MRELO (75°F (24°C)). For example: toggle M REL LO which permits the OK/EXIT key to be operational above 75°F (24°C) to exit the shortening melt mode. Press the OK/EXIT key to accept this selection.	A. M REL HI / M REL LO will be displayed to indicate this selection has been accepted. B. When OK/EXIT key is pressed, FEATURE will appear in the display.						
11	Depress Feature Key “6” then the  key to toggle between the VIEW RECOVERY TEST OPTIONS , i.e., LAST , PREVIOUS and FACTORY . While viewing FACTORY , a new value can be entered by depressing the OK/EXIT key first then entering 3 DIGITS in seconds. Depress the OK/EXIT Key to exit this feature.	A. LAST/PREV/FCTY will appear in the display. B. When OK/EXIT key is pressed, FEATURE will appear in the display.						
12	Depress Feature Key “7” to program the FILTER PROMPT .	A. Prompt FHCL ### will be displayed indicating the FILTER HIT COUNT LIMIT for the Filter prompt may be entered.						
13	Enter the maximum number of HITS (product drops) to be cooked prior to alarming a FILTER PROMPT ; then press the OK/EXIT key. For example: enter 105 NOTES: 1) If filtering shortening was recommended after cooking a THOUSAND pieces of battered chicken, that would equate to cooking 48 pieces of battered chicken about 21 times. Therefore the max number of HITS (product drops) prior to alarming a FILTER PROMPT would be 105 (Hit Count Value 5 x 21 Product Drops). 2) Maximum value that can be entered is 999. 3) Entering  will disable this feature.	A. Current Filter Hit Counts FHCS 105 will be displayed indicating a filter prompt will be signaled after the following quantity of product has been cooked, for example: <table data-bbox="950 892 1404 976"> <tr> <td>CHICKEN</td> <td>1008 PIECES</td> </tr> <tr> <td>FRENCH FRIES</td> <td>105 BASKETS</td> </tr> <tr> <td>FILLETS</td> <td>262 PIECES</td> </tr> </table>	CHICKEN	1008 PIECES	FRENCH FRIES	105 BASKETS	FILLETS	262 PIECES
CHICKEN	1008 PIECES							
FRENCH FRIES	105 BASKETS							
FILLETS	262 PIECES							
14	Depress the OK/EXIT key to get the TIME PROMPT LIMIT display.	A. TIME PROMPT LIMIT (TIME xx) will be displayed, indicating TIME PROMPT LIMIT may be entered.						
15	Enter time of operation, in hours, before a TIME PROMPT LIMIT will be displayed. For example; enter 02 . Press the OK/EXIT key for this value to be accepted. NOTE: Entering  will disable this feature.	A. TIME 02 will be displayed indicating the entry has been accepted. B. When OK/EXIT key is pressed, FEATURE will appear in the display.						
16	Press Feature Key “8” to program the shortening DISPOSAL PROMPT .	A. Prompt DHL ##### will be displayed indicating the DISPOSAL HIT COUNT LIMIT for the Disposal Prompt may be entered.						
17	Enter the maximum number of HITS (product drops) to be cooked prior to alarming a DISPOSAL PROMPT . For example: enter 01458 . Press the OK/EXIT key for this value to be accepted. NOTES: 1) If shortening disposal was recommended after cooking 14,000 pieces of battered chicken, that would equate to cooking 48 pieces of battered chicken about 292 times. Therefore the max number of HITS (product drops) prior to alarming a DISPOSAL PROMPT would be 1458 (Hit Count Value 5 x 292 Product Drops). 2) Maximum value that can be entered is 65,535. 3) Entering  will disable this feature.	A. Current Disposal Hit Count DHCO 3704 will be displayed indicating a DISPOSAL PROMPT will be signaled after the following quantity of product has been cooked. For example: <table data-bbox="976 1602 1404 1686"> <tr> <td>CHICKEN</td> <td>14,016 PIECES</td> </tr> <tr> <td>FRENCH FRIES</td> <td>1,458 BASKETS</td> </tr> <tr> <td>FILLETS</td> <td>3,645 PIECES</td> </tr> </table> B. When the OK/EXIT key is pressed FEATURE will appear in the display.	CHICKEN	14,016 PIECES	FRENCH FRIES	1,458 BASKETS	FILLETS	3,645 PIECES
CHICKEN	14,016 PIECES							
FRENCH FRIES	1,458 BASKETS							
FILLETS	3,645 PIECES							
18	Press the SET key to exit the programming mode.							

V WIRING DIAGRAMS

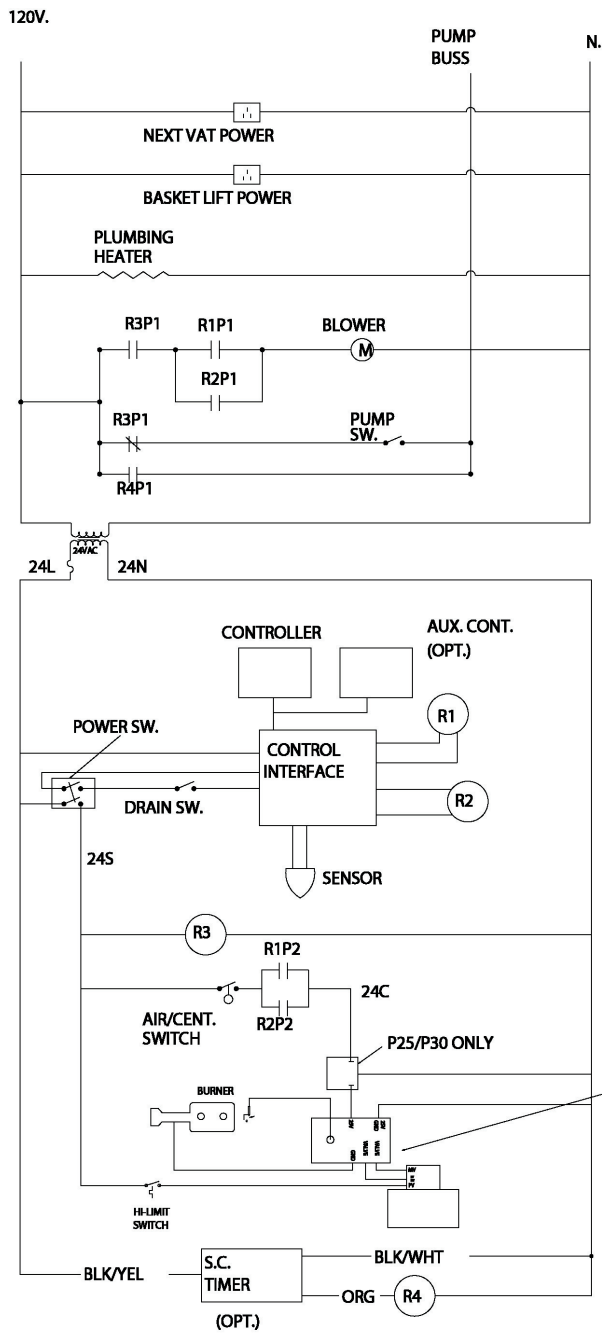

THIS DECAL IS LOCATED ON THE FAR RIGHT SIDE BACK PANEL FROM FRONT

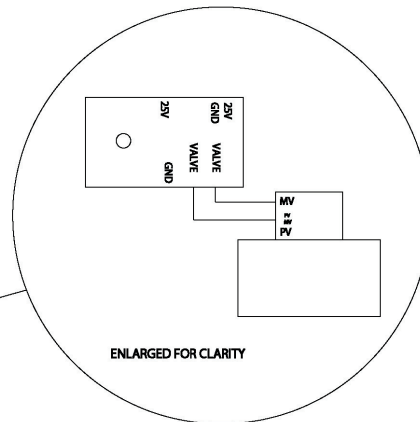

30A161

GAS FRYER W/COMPUTER WIRING DIAGRAM