



MODEL EU-14 EU-18 & EU-20 Electric Fryer Operation Instruction



THIS APPLIANCE IS FOR PROFESSIONAL USE AND IS TO BE USED ONLY BY QUALIFIED PERSONNEL

302 Spencer Lane • P.O. Box 5369

(800) 525-8130 • (210) 731-5000 • Fax: (210) 731-5099
www.ultrafryer.com

San Antonio, Texas 78201

30A187 CE revA March 2015

PREFACE

This manual was written and published by the Technical Publications Department, Ultrafryer Systems, for use by personnel who operate an Ultrafryer Model EUF Electric Fryer equipped with an Ultrastat 23 Cooking Computer.

**TECHNICAL PUBLICATIONS DEPARTMENT
ULTRAFRYER SYSTEMS
302 SPENCER LANE
SAN ANTONIO, TX 78201
1-800-545-9189 EXT. 5007**

NOTE: This manual is applicable to “Standard” Electric Model EUF Bank of Fryers. It can be used as a guide in operating special variations of an Electric Model EUF Bank of Fryers. It also replaces Model EU Electric Fryer Maintenance & Repair Manual PN 30A013.

TABLE OF CONTENTS

GENERAL INFORMATION PAGE

Preface	2
Table of Contents.....	3
Safety Information	4-7
General Information	8-10
Description / Specifications	11-13
INSTALLATION, START UP, and INITIAL CLEANING	14
Pre –Installation Instructions & Warnings	15-16
Install & Dis-assembly	17
Clearance, Ventilation & Electrical Grounding	18
Re-assembly	19-20
Leveling, Electrical Connection, & Initial Cleaning	22
FRYER START-UP	23
Shortening Installation	24
Computer Panel Key Description	25
Computer Programming	26
Fryer Start Up & Cooking	27-28
FILTERING INSTRUCTIONS	29
General	30
Filtering Shortening	31-33
Boiling Out Fryer	34
Cleaning	35-37
PREVENTIVE MAINTENANCE & TROUBLESHOOTING	38
Preventive Maintenance	40
Troubleshooting	40
SERVICE AND PARTS	41
Technical Assistance & Parts Ordering Information	42
Parts List	43
WIRING DIAGRAMS	44
Incoming Power	45
Ladder diagram	46

SAFETY INFORMATION

THIS APPLIANCE IS INTENDED FOR PROFESSIONAL USE AND IS TO BE OPERATING BY QUALIFIED PERSONNEL

Throughout this manual **NOTES**, **CAUTIONS** and **WARNINGS** are used to alert the operator to items of special circumstances. These items are identified as follows:

NOTES

These Items will be indented from the main text, the word “NOTE” will be in capital letters. These items alert the operator to items of special concern to achieve a desired result.

Examples:

NOTE:

Pull on the filter tub to ASSURE the male docking plug is SEATED in the female bulkhead socket

CAUTIONS: These items will be indented from the main body of text, the word “CAUTION” will be in bold, capitalized print and the entire text will be enclosed by a border. These items identify steps or procedures that if not adhered to could result in product, equipment malfunction or failure and the entire text will be enclosed by a bold border. These items identify steps or procedures that if not adhered to could result in property damage, injury or death.

CAUTION



TO ASSURE PRODUCING A QUALITY PRODUCT WHILE PROLONGING THE LIFE EXPECTANCY OF THE FRYER, ENSURE FILTERING, BOIL-OUT AND CLEANING INSTRUCTIONS ARE STRICTLY ADHERED TO.

WARNINGS

These items will be indented from the main body of text, the word “WARNING” as well as the text will be in bold, capitalized print

WARNING



DO NOT ALLOW ANY CLEANING SOLUTION OR WATER TO SPLASH INTO A VESSEL OF HOT COOKING OIL, AS IT WILL CONTAMINATE THE OIL AND MAY CAUSE THE OIL TO SPLATTER CAUSING SEVERE BURNS.

DANGER

These items will be indented from the main body of the text, the word “DANGER” as well as the text will be in bold. Capitalized print.

DANGER



DO NOT STORE GASOLINE AROUND OR NEAR ANY KIND OF OPEN FLAME.

NOTICE

IF, DURING THE WARRANTY PERIOD, THE CUSTOMER USES A PART FOR THIS ULTRAFRYER EQUIPMENT OTHER THAN AN UNMODIFIED NEW OR RECYCLED PART PURCHASED DIRECTLY FROM ULTRAFRYER SYSTEMS OR ANY OF ITS AUTHORIZED SERVICE CENTERS, AND/OR THE PART BEING USED IS MODIFIED FROM ITS ORIGINAL CONFIGURATION, THIS WARRANTY WILL BE VOID. FURTHER, ULTRAFRYER SYSTEMS AND ITS AFFILIATES WILL NOT BE LIABLE FOR ANY CLAIMS, DAMAGES, OR EXPENSES INCURRED BY THE CUSTOMER WHICH ARISE DIRECTLY OR INDIRECTLY, IN WHOLE OR IN PART, DUE TO THE INSTALLATION OF ANY MODIFIED PART AND/OR PART RECEIVED FROM AN UNAUTHORIZED SERVICE CENTER.



DANGER

The electrical power supply for this appliance must be the same as indicated on the rating and serial number plate located on the outside of the fryer door .



DANGER

All wiring connections for this appliance must be made in accordance with the wiring diagrams furnished with the equipment.



DANGER

Do not store or use gasoline or other flammable vapors and liquids in the vicinity of this or any other appliance.



DANGER

Do not store or use gasoline or other flammable vapors and liquids in the vicinity of this or any other appliance.



WARNING

Do not attach accessories to this fryer unless fryer is secured from tipping. Personal injury may result.



WARNING

Do not use water jets to clean this equipment.



WARNING

This equipment is intended for indoor use only. Do not install or operate this equipment in outdoor areas.



DANGER

The front apron of this appliance is not a step! Do not stand on the appliance, Serious injury can result from slips or contact with the hot oil.



DANGER

Do not store or use gasoline or other flammable liquids or vapors of this or any other appliance.



DANGER

The crumb tray in fryers equipped with a filter systems must be emptied into a fireproof container at the end of frying operation each day. Some food particles can spontaneously combust if left soaking in certain shortening material.



WARNING

Do not bang fry baskets or other utensils on the fryer's joiner strip. The strip is present to seal the joint between the fry vessels. Banging fry baskets on the strip to dislodge shortening will distort the strip, adversely affecting its fit. It is designed for a tight fit and should only be removed for cleaning.



DANGER

Adequate means must be provided to limit the movement of this appliance without depending on or transmitting stress to the electrical conduit. A restraint kit is provided with the fryer or local dealer.



DANGER

Prior to movement, testing, maintenance and any repair on your Ultrafryer, disconnect all electrical power from the fryer.



WARNING

No structural material on the fryer should be altered or removed to accommodate placement of the fryer under a hood.

NOTICE

This appliance is intended for professional use only and is to be operated by qualified personnel only. A qualified professional should perform installation, maintenance, and repairs. Installation, maintenance, or repairs by unqualified personnel may void the manufacturer's warranty.

NOTICE

This equipment must be installed in accordance with the appropriate national and local codes of the country and/or region in which the appliance is installed. See NATIONAL CODE REQUIREMENTS of this manual for specifics.

NOTICE

Drawings and photos used in this manual are intended to illustrate operational, cleaning technical procedures and may not conform to onsite management operational procedures.



DANGER

Improper installation, adjustment, maintenance or service, and unauthorized alterations or modifications can cause property damage, injury, or death. Read the installation, operating, and service instructions thoroughly before installing or servicing this equipment.

GENERAL INFORMATION

ULTRAFRYER EUF SERIES ELECTRIC FRYER INTRODUCTION

1.1 General

This manual covers all configurations of EUF series electric fryers. The fryers in this model family have most parts in common, and when discussed as a group, will be referred to as “EUF” electric fryers.

1.2 Safety Information

Before attempting to operate your unit, read the instructions in this manual thoroughly. Throughout this manual, you will find notations enclosed in bordered boxes similar to the one below.



DANGER

Hot cooking oil causes severe burns. Never attempt to move a fryer containing hot oil or to transfer hot oil from one container to another.



CAUTION boxes contain information about actions or conditions that *may cause or result in a malfunction of your system.*



WARNING boxes contain information about actions or conditions that *may cause or result in damage to our system, and which may cause your system to malfunction.*



DANGER boxes contain information about actions or conditions that *may cause or result in injury to personnel, and which may cause damage to your system and/or cause your system to malfunction.*

Fryers in this series are equipped with the following automatic safety features:

1. High-temperature detection features shut off power to the elements should the temperature controls fail.
2. A safety switch built into the drain valve prevents the elements from heating with the drain valve even partially open.

1.3 Controller Information

This equipment has been tested and found to comply with the limits for a Class A digital device, pursuant to Part 15 of the FCC rules. While this device is a verified Class A device, it has been shown to meet the Class B limits. These limits are designed to provide reasonable protection against

harmful interference when the equipment is operated in a commercial environment. This equipment generates, uses and can radiate radio frequency energy and, if not installed and used in accordance with the instruction manual, may cause harmful interference to radio communications. Operation of the equipment in a residential area is likely to cause harmful interference in which case the user will be required to correct the interference at their own expense.

The user is cautioned that any changes or modifications not expressly approved by the party responsible for compliance could void the user's authority to operate the equipment.

If necessary, the user should consult the dealer or an experienced radio and television technician for additional suggestions.

The user may find the following booklet prepared by the Federal Communications Commission helpful: "How to Identify and Resolve Radio-TV Interference Problems". This booklet is available from the U.S. Government Printing Office, Washington, DC 20402, Stock No. 004-000-00345-4. 1.4 European Community (CE) Specific Information The European Community (CE) has established certain specific standards regarding equipment of this type. Whenever a difference exists between CE and non-CE standards, the information or instructions concerned are identified by means of shadowed boxes similar to the one below.

CE STANDARD

Example of box used to distinguish CE and Non-CE specific information.

A. Installation, Operating, and Service Personnel

Operating information for Ultrafryer equipment has been prepared for use by qualified and/or authorized personnel only, as defined in Section 1.6. All installation and service on Ultrafryer equipment must be performed by qualified, certified, licensed, and/or authorized installation or service personnel, as defined in Section 1.6.

B. Definitions

1. QUALIFIED AND/OR AUTHORIZED OPERATING PERSONNEL

Qualified/authorized operating personnel are those who have carefully read the information in this manual and have familiarized themselves with the equipment functions, or who have had previous experience with the operation of the equipment covered in this manual.

2. QUALIFIED INSTALLATION PERSONNEL

Qualified installation personnel are individuals, firms, corporations, and/or companies which, either in person or through a representative, are engaged in and are responsible for the installation of electrical appliances. Qualified personnel must be experienced in such work, be familiar with all electrical precautions involved, and have complied with all requirements of applicable national and local codes.

3. QUALIFIED SERVICE PERSONNEL

Qualified service personnel are those who are familiar with Ultrafryer equipment and who have been authorized by Ultrafryer. to perform service on the equipment. All authorized service personnel are required to be equipped with a complete set of service and parts manuals, and to stock a minimum amount of parts for Ultrafryer equipment. A list of Ultrafryer Factory Authorized Servicers (FAS's) is located on the Ultrafryer website at www.ultrafryer.com. ***Failure to use qualified service personnel will void the Ultrafryer warranty on your equipment.***

SAFETY

The major safety factor associated with the Ultrafryer Model EUF Electric Fryer is burns from hot shortening. In order to prevent serious burns, good housekeeping habits are required. The floor in front of and the area around the fryer should be kept clean and dry. Whenever anything is placed in to a fryer vat, care should be used not to splash the hot shortening. Product should always be “PLACED” into the shortening, not thrown. Safety goggles, neoprene insulated gloves and an apron must be worn while filtering or boiling-out a fryer vat. Extreme caution should be exercised when connecting the “Wash Down Hose’ QUICK-CONNECT COUPLER to the QUICK-CONNECT STEM on the rear wall of the fryer vat during filtering or boil-out operations. If this plug is not securely attached to the stem, HOT shortening will be discharged around this connection which could cause SEVERE BURNS. The Ultrafryer Model EUF Electric Fryer utilizes 120 volts and 208, 220, 240, 380, 400, 415 or 480 volts, single and three phase electrical power and no adjustments or replacement of electrical controls or parts should ever be attempted without first disconnecting ALL electrical power. FAILURE to do so could result in serious electrical shock or death. Electrical power to the fryer is supplied from more than one (1) circuit breaker and it should be determined that ALL electrical power has been removed prior to beginning a repair. The fryer and its controls should not be operated with wet hands or while standing in water. To do so can result in serious electrical shock or death.

Fire in liquid shortening should always be a constant concern of team members operating or working nearby the Electric Fryer. The fryer should be equipped with a Fire Suppression system, that automatically OPENS the shunt trip circuit breakers, removing electrical power from the fryer if a fire occurs. In addition, this system MUST be inspected by a licensed distributor each six (6) months to assure it is operational.

DESCRIPTION/SPECIFICATIONS

The Ultrafryer Model EUF Electric Fryer is constructed from 16 and 18 gauge, type 304 polished satin finished stain-less steel. Most Model EUF Electric Fryers are equipped with an Ultrastat Model 23 Cooking Computer. In addition, the Model EUF Electric Fryer has a shortening Filtration system that uses a Permafil Stainless Steel Filter Screen. The customer has the option of ordering a Magnepad Filter System that uses a Paper Filter Pad in lieu, of a S/S filter screen. The dimensions of each size fryer is as follows:

ITEM DESCRIPTION	EUF-14		EUF-18		EUF-20	
	In. (mm)		In. (mm)		In. (mm)	
Overall Width	15½”	(394)	19½”	(494)	21½”	(546)
Overall Depth	28¾”	(730)	38¾”	(984)	38¾”	(984)
Work Height	36”	(914)	36”	(914)	36”	(914)
Oil Capacity						
High Level		----	110 lbs	(55 liters)	138 lbs	(69 liters)
Low Level	45 lbs	(22.5 liters)	70 lbs	(35 liters)	----	
Shipping Cube	10.49 ft³	(.30 m³)	18.01 ft³	(.51 m³)	19.77 ft³	(.56 m³)
Shipping Weight	235 lbs	(106 kgs)	265 lbs	(116 kgs)	275 lbs	(124 kgs)

NOTE: Test Start-Up, Operation, Cooking, Filtering, and Boil-Out Procedures of a Model EUF Electric Fryer in this manual are based on the Ultrastat 23 Cooking Computer Procedures. Refer to Manual Instruction to form these functions in a fryer equipped with this controls.

POWER REQUIREMENTS TABLE

MODEL	VOLTS Rated	VOLTS Applied	#WIRES	MIN WIRE SIZE		KW 2 ELEM	AMPS per leg
				AWG	MM		
EUF14 17KW	208	208	3	6	4.11	17KW	42
		240	3	6	4.11	22.6KW	48.5
		220/380	4	6	4.11	18.9KW	25.5
		230/400	4	6	4.11	20.9KW	26.9
		240/415	4	6	4.11	22.5KW	27.9
		480	3	8	2.59	30.2KW	32.3
EUF18 20KW	208	208	3	6	4.11	20KW	56
		240	3	6	4.11	26.6KW	64.5
		220/380	4	6	4.11	22.2KW	34
		230/400	4	6	4.11	24.6KW	35.8
		240/415	4	6	4.11	26.5KW	37.2
		480	3	8	2.59	35.5KW	43.1
EUF20 20KW	208	208	3	6	4.11	20KW	56
		240	3	4	4.11	26.6KW	64.5
		220/380	4	6	4.11	22.2KW	34
		230/400	4	6	4.11	24.6KW	35.8
		240/415	4	6	4.11	26.5KW	37.2
		480	3	8	2.59	35.5KW	43.1

POWER REQUIREMENTS TABLE

MODEL	VOLTS	VOLTS	#WIRES	MIN WIRE SIZE		KW 2 ELEM	AMPS per leg
	Rated	Applied		AWG	MM		
EU14 17KW	240	208	3	6	4.11	12.8KW	35.5
		240	3	6	4.11	17.0KW	40.9
		220/380	4	6	4.11	14.2KW	21.5
		230/400	4	6	4.11	15.7KW	22.7
		240/415	4	6	4.11	16.9KW	23.5
		480	3	8	2.59	22.7KW	27.3
EU18 20KW	240	208	3	6	4.11	15.0KW	41.6
		240	3	6	4.11	20.0KW	48.1
		220/380	4	6	4.11	16.7KW	25.4
		230/400	4	6	4.11	18.5KW	26.7
		240/415	4	6	4.11	19.9KW	27.7
		480	3	8	2.59	26.7KW	32.1
EU20 20KW	240	208	3	6	4.11	15.0KW	41.6
		240	3	6	4.11	20.0KW	48.1
		220/380	4	6	4.11	16.7KW	25.4
		230/400	4	6	4.11	18.5KW	26.7
		240/415	4	6	4.11	19.9KW	27.7
		480	3	8	2.59	26.7KW	32.1

INSTALLATION, START UP, AND INITIAL CLEANING

NOTIFICATION

All installation and service on Ultrafryer equipment must be performed By qualified, licensed, and/or authorized installation or service personnel. Qualified personnel must be experienced in such work, be familiar with all electrical precautions involved, and have complied with all requirements of applicable national and local codes.

ELECTRIC FRYER INSTALLATION INSTRUCTIONS

General

Proper installation is essential for the safe, efficient, trouble-free operation of this appliance.

Qualified, licensed, and/or authorized installation or service personnel, as defined in Section of this manual, should perform all installation and service on Ultrafryer equipment.

Failure to use qualified, licensed, and/or authorized installation or service personnel (as defined in Section of this manual) to install or otherwise service this equipment will void the Ultrafryer warranty and may result in damage to the equipment or injury to personnel.

Where conflicts exist between instructions and information in this manual and local or national codes or regulations, installation and operation shall comply with the codes or regulations in force in the country in which the equipment is installed.

Service may be obtained by contacting your local Factory Authorized Servicer.

NOTICE

All fryers shipped without factory supplied cords and plug assemblies must be hardwired using flexible conduit to the terminal block located on the rear of the fryer. These fryers should be wired to NEC specifications. Hardwired units must include installation of restraint devices.

NOTICE

If this equipment is wired directly into the electrical power supply, a means for disconnection from the supply having a contact separation of at least 3-mm in all poles must be incorporated in the fixed wiring.

NOTICE

This equipment must be positioned so that the plug is accessible unless other means for disconnection from the power supply (e.g., a circuit breaker) is provided.

NOTICE

If the electrical power supply cord is damaged, it must be replaced by a Ultrafryer Factory Authorized Servicer or a similarly qualified person in order to avoid a hazard.



DANGER

All wiring connections for this appliance must be made in accordance with the wiring diagram(s) furnished with the appliance. Refer to the wiring diagram(s) affixed to the inside of the appliance door when installing or servicing this equipment.

NOTICE

If this appliance is permanently connected to fixed wiring, it must be connected by



DANGER

This appliance must be connected to a power supply having the same voltage



DANGER

All wiring connections for this appliance must be made in accordance with the wiring diagram(s) furnished with the appliance. Refer to the wiring diagram(s) affixed to the inside of the appliance door when installing or servicing this equipment.



DANGER

No structural material on the fryer should be altered or removed to accommodate placement of the fryer under a hood. Questions? Call the Ultrafryer Service Hotline at 1-800-525-8130.

INSTALLATION

GENERAL - Each Model EUF Electrical Fryer should be installed as follows:

1. Properly unpacked and positioned at its operating location within the store.
2. Placed beneath a properly designed exhaust hood and protected by a Fire Suppression System
3. **LEVELED** using a spirit level to assure each vat contains the proper amount of shortening.
4. Installed by a licensed electrician and connected to the 1 phase and 3 phase voltages shown on the data plate.
5. Restrained by use of a restraining device to avoid splashing hot liquid and to ensure tension cannot be placed on electrical connections.



WARNING: UNPACKING - Check that the container is upright. Use an outward prying motion. **DO NOT USE A HAMMER** to remove the wood braces and carton. Check the fryer bank for visible damage; if damage has occurred do not refuse shipment, but contact the carrier and file the appropriate freight claims. Remove the two shipping bolts in the front and rear legs and remove the two 2" x 6" (51mm x 152mm) wood supports.

INSTALLING - If sufficient clearance is available to roll the assembled fryer bank into the building, proceed to the **LEVELLING** paragraph below. In the event entrance doors are too narrow to roll the assembled fryer into the building; disassemble and reassemble the fryer as follows:

reassemble the fryer as follows:

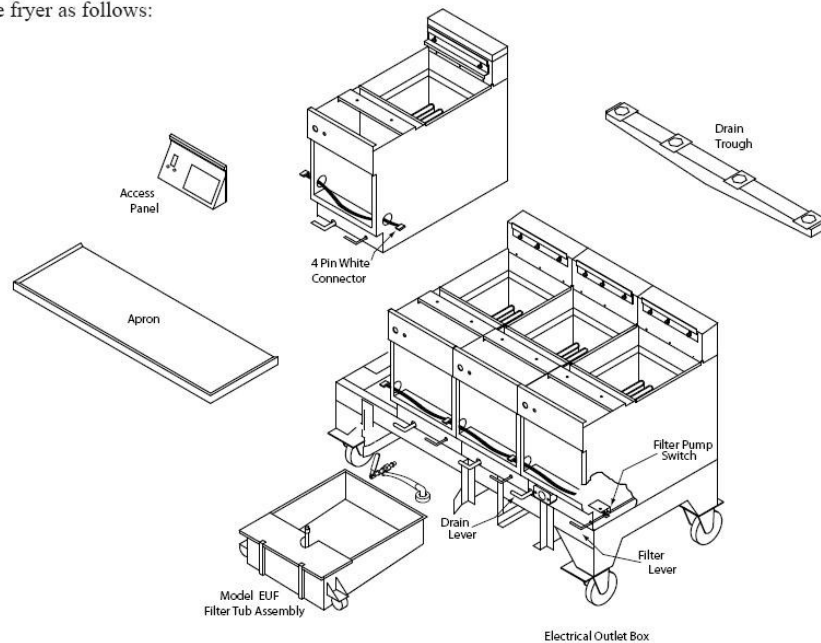

DIS-ASSEMBLY

- A. Perform the following steps facing the **FRONT** of the fryer:
1. Number each vat cabinet from **LEFT** to **RIGHT** and place these numbers on the front and rear Panel of each cabinet.
 2. Lower the Temperature Control access panel from each vat cabinet.
 3. **CAREFULLY** remove the **APRON** from the fryer bank by removing the two (2) 1/4 - 20 wing nuts, 1/4" split washers, and n" flat washers from each 1/4 - 20 weld stud beneath each cabinet hat section.

NOTE: It may be necessary to cut the **SILICONE SEAL** between the apron and vat cabinets to separate the apron. **DO NOT DAMAGE THE GASKET.**

4. CAREFULLY disconnect the 4 PIN WHITE connector from its mating receptacle located on the LOWER right hand end of each vat; then remove the BLACK wiring harness protector from the 2" opening in each Vat.
5. CAREFULLY disconnect the ELECTRICAL OUTLET BOX BLACK and WHITE electrical wires connect- ed to wires by WIRE NUTS located on the LEFT HAND side of the "extreme" RIGHT HAND vat.
6. Remove the 10 - 24 truss head screw and nut on the right hand side of each vat used to secure adjoining vats and remove the 10 - 24 truss head screw and nut that secures the "extreme" left hand vat cabinet to the base frame.

B. Perform these steps facing the REAR of the fryer:

1. Remove the REAR panel from each vat by removing the four (4) pan head self-tapping screws.
2. Remove the two (2) 10 - 24 truss head screws and nuts on the right hand side of each vat used to secure adjoining vats.

NOTE: It may be necessary to loosen and move the two (2) electrical contactors to gain access to these screws and nuts.

3. CAREFULLY remove the two (2) philips head self-tapping screws along the BOTTOM flange of each cabinet.
4. CAREFULLY disconnect the SHORTENING LINE RED and WHITE heater tape electrical wires terminated in the terminal block of the EXTREME right hand fryer.
5. CAREFULLY disconnect the FILTER PUMP MOTOR RED, GREEN and WHITE electrical wires terminat- ed in a 4 PIN WHITE connector from its mating receptacle located on the left hand side of the "extreme" LEFT HAND vat.
6. CAREFULLY disconnect the POWER LINE BLACK and WHITE electrical wires terminated in a 4 PIN WHITE connector from its mating receptacle located on the left hand side of the "extreme" LEFT HAND vat.
7. SECURE the SHORTENING LINE to the base frame on the LEFT HAND end of the fryer bank; then CAREFULLY loosen and separate the shortening line union attached to each 3/4" ball valve.
8. CAREFULLY remove each cabinet from the base frame, carry each cabinet into the building; then place the base frame into position in the kitchen.
9. PRIOR to re-assembling the fryer bank, remove DRIED silicone used to seal the apron to vats, opening between each set of vats, front and rear of each cabinet, lower edge of the two (2) end vats, and perimeter of the base frame.

RE-ASSEMBLY

- A. Place each vat cabinet in numerical order in FRONT of the base frame from LEFT to RIGHT.
- B. Install each vat cabinet on the base frame as follows:
 1. Place a bead of silicone around the perimeter of the base frame for the FIRST vat cabinet.
 2. CAREFULLY place VAT CABINET #1 in position on the base frame; then secure the cabinet to the base frame by installing a 10 - 24 truss head screw and nut on the left hand flange to the base frame then install two (2) philips head self- tapping screws in the two holes on the REAR bottom flange of the cabinet.
 3. Repeat the above procedures to install remaining vat cabinets on the base frame.
- C. When all vat cabinets are installed on the base frame, secure the cabinets as follows:
 1. Place a bead of silicone along the FRONT, TOP and REAR space between vat cabinets #1 and #2.
 2. Install a 10-24 truss head screw and nut in the 1/4" holes on the FRONT right hand side of vat cabinet #1 and left hand side of vat cabinet #2.
 3. Install two (2) 10-24 truss head screws and nuts in the two (2) x" holes on the REAR left hand side of vat cabinet #1 used to secure it to cabinet #2.
 4. Repeat the above procedures to secure remaining vat cabinets to adjoining vat cabinets.

D. Perform these steps facing the REAR of the fryer:

1. CAREFULLY connect each shortening line union HAND TIGHT, remove the device used to secure the SHORTENING LINE to the LEFT end of the base frame; then SECURELY tighten each shortening line union.
2. SECURELY connect the SHORTENING LINE RED and WHITE heater tape electrical wires to the Black and White wire terminals on the Terminal Block of the EXTREME right vat.
3. SECURELY connect the FILTER PUMP MOTOR RED, GREEN and WHITE electrical wires terminated in a 4 PIN WHITE connector to its mating receptacle located on the left-hand side of the “extreme” LEFT HAND vat.
4. SECURELY connect the POWER LINE BLACK and WHITE electrical wires terminated in a 4 PIN WHITE connector to its mating receptacle located on the left hand side of the “extreme” LEFT HAND vat.
5. Install a large cabletye on the cable harness on the “extreme” LEFT and RIGHT vats; then replace the REAR PANEL on each vat cabinet using four (4) pan head self-tapping screws in each cabinet panel and fan cover.

E. Perform these steps facing the FRONT of the fryer:

1. Install the BLACK wiring harness protector in the 2” opening of each vat; then SECURELY connect the 4 PIN WHITE wiring harness connector to its mating receptacle on each vat.
2. CAREFULLY connect the ELECTRICAL OUTLET box BLACK and WHITE wires on the “extreme” right hand vat to the POWER line BLACK and WHITE wires using the wire nuts previously removed.
3. Remove any dried silicone from the SHORTENING DRAIN TROUGH, place a bead of silicone to the same location on the drain trough, position the drain trough beneath the fryer; then SECURE the drain trough to each 2” ball valve plate using four (4) 1/4 - 20 hex head bolts and nuts previously removed.
4. Remove any dried silicone from each JOINER STRIP, place a bead of silicone in each strip; then place the joiner strip over the edge of all adjoining fryer vats.
5. CAREFULLY replace the APRON as follows:
 - a. Remove any dried silicone from the front edge of each vat cabinet and the bottom of the APRON.
 - b. Place a bead of silicone along the FRONT edge of each vat cabinet and fill the REAR corners of the apron with silicone so it will be flush with the top of the apron.
 - c. Place the apron in position with the REAR flange towards the FRONT inside edge of each vat and the FRONT of the apron, elevated approximately 45 degrees; seat the rear flange of the apron over the front inside edge of each vat; then CAREFULLY lower the front of the apron until each 1/4 - 20 weld stud is seated in the notches of the front and rear hat section of each cabinet. Slip the apron a little bit to the left and right to center it on the fryer.
 - d. When the apron is properly positioned, secure it to the hat sections of each cabinet using the wing nuts, split washers and the flat washers removed earlier.
 - e. After the apron has been secured to each fryer cabinet, apply a small bead of multi-purpose sealant to the areas shown in the sketch below.

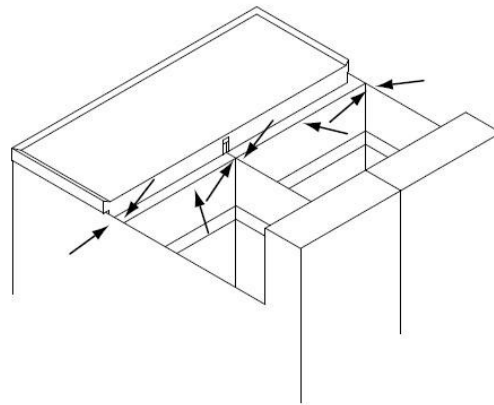

6. Replace the Temperature Control Access Panel.

DIS-ASSEMBLY, Continue

A. Continue

4. Remove the **JOINER STRIP** located between each set of vats; then cut the **SILICONE SEAL** between the vats.

5. **CAREFULLY** separate the **SHORTENING DRAIN TROUGH** from each 2” ball valve plate by removing the four (4) 1/4 - 20 hex head bolts and nuts; then remove the drain trough from the fryer.



WARNING

A neoprene gasket was placed between the ball valve and drain trough opening of each vat and sealed with silicone. Therefore it may be necessary to use a sharp instrument to separate the trough from the valve. **DO NOT DAMAGE THE NEOPRENE GASKET.**



DANGER

Do not attach an apron drainboard to a single fryer. The fryer may become unstable, tip over and cause injury. The appliance area must be kept free and clear of combustible material at all times.

In the event of a power failure, the fryer(s) will automatically shut down. If this occurs, turn the power switch OFF. Do not attempt to start the fryer(s) until power is restored.

Clearance and Ventilation

This appliance must be kept free and clear of combustible material.

A clearance of 6 inches (15cm) must be provided at both sides and back adjacent to combustible construction. A minimum of 24 inches (61cm) should be provided at the front of the equipment for servicing and proper operation.



WARNING

Do not block the area around the base or under the fryers.

Electrical Grounding Requirements

All electrically operated appliances must be grounded in accordance with all applicable national and local codes, and, where applicable, CE codes. All units (cord connected or permanently connected) should be connected to a grounded power supply system. A wiring diagram is located on the inside of the fryer door. Refer to the rating plate on the inside of the fryer door for proper voltages.

Australian Requirements

To be installed in accordance with AS 5601 / AG 601, local authority, gas, electricity, and any other relevant statutory regulations.

LEVELING - After the Ultrafryer Electric Fryer has been properly positioned in the store, it should be **LEVELED** using a Spirit Level by inserting the appropriate number of shim plates between each leg and caster plate. Leveling will assure that each vat contains the same amount of shortening when checked at the engraved shortening level mark on the rear wall of the fryer vat.

ELECTRICAL CONNECTION - Each Model EUF Electric Fryer is wired internally to operate on 230 volt single phase and 380 or 415 volt 3 phase electrical power as shown on the fryer's rating plate. The 230 volt control circuit of each individual fryer in a bank of fryers are internally wired in parallel to an eight (8) foot 230 volt electrical cord with a molded electrical plug. The 380 or 415 volt 3 phase circuit of each fryer in a bank of fryers is internally wired to a **SEPARATE** terminal block which is to be used to connect to the building power source. It is **ESSENTIAL** that the 230 volt electrical receptacle is located within 8 feet of the fryer bank location and that provisions are made so that the fryer bank can be moved to service fryers from the rear. Electrical connections to the fryer bank should be made by a licensed electrician, and they must conform to all local electrical codes and/or ordinances. To avoid electrical hazards and assure proper operation of the electric fryer, the following precautions should be observed during installation:

- A. **MATCH VOLTAGE:** Before connecting electrical power, insure the line voltage matches the voltage rating on the fryer's data plate.
- B. **CIRCUIT BREAKERS:** The fryer must be connected to a circuit having shunt-trip circuit breakers sized in accordance with requirements of all local electrical codes and ordinances.
- C. **GROUNDING:** The fryer **MUST** be grounded to the building ground system according to local electrical codes and ordinances.
- D. **FIRE PROTECTION:** The fryer should be installed beneath a powered exhaust hood which complies with local electrical codes and ordinances and which is equipped with an approved Fire Suppression System designed to automatically shut off all sources of electrical power to the fryer in case of a vat fire.
- E. **CLEARANCES** - The Model EUF Electric Fryer **MUST** be kept free and clear of all combustibles. The **MINIMUM** clearances from combustible and non-combustible construction is 6" (152 mm) from the sides and 6" (152 mm) from the rear of the fryer. The fryer may be installed on combustible floors.

INITIAL CLEANING

New Electric Fryers are wiped clean with solvents at the factory to remove any visible signs of dirt, oil, grease, etc. remaining from the manufacturing process; then given a light coat of oil. Each fryer and filter tub assembly should be **THOROUGHLY** washed with **HOT** sanitizer solution to remove film residue, installation dust or debris and then wiped dry prior to placing the fryer into operation.

FRYER START-UP

SHORTENING INSTALLATION

A. LIQUID SHORTENING: When using liquid shortening (cooking oil) fill the fryer with shortening to the bend line between the words “MIN and MAX” on the rear wall of the fryer vat.

B. SOLID SHORTENING:

1. Cut a block of solid shortening into small pieces.
2. Place small pieces of solid shortening EVENLY on top of the HEAT MECHANISM or THOROUGHLY PACK these pieces of solid shortening between, below and above the HEAT MECHANISM. While packing solid shortening is messy and time consuming, it is the safest and fastest way to melt solid shortening.
3. Ultrastat 21 equipped Fryer
 - A. Turn the fryer Toggle ON/OFF switch ON; then place the computer in the SHORTENING MELT MODE by depressing the ON/OFF button. The MELT lamp will LIGHT to indicate the computer is in the SHORTENING MELT MODE; and the HEAT lamp and RED heat mechanism indicator lamp on the fryer will cycle ON and OFF indicating the heat mechanism is periodically being turned ON and OFF to gently heat the shortening.
 - B. When the heat mechanism is COMPLETELY covered with LIQUID shortening and the shortening is ABOVE the Melt Limit Temperature, replace the grill in the fryer vat; then push the EXIT MELT button on the computer. Proceed to Paragraph B 5) below.
4. Continue adding solid shortening as follows:
 - A. Place small pieces of solid shortening into a fry basket.
 - B. CAREFULLY lower the basket into the fryer vat.
 - C. GENTLY turn the basket to allow these pieces of solid shortening to float away.
 - D. Repeat the above steps until liquid shortening is even with the bend line of the fryer vat between the words “MIN and MAX” on the rear wall of the fryer vat.



WARNING

- | |
|--|
| <p>I DO NOT MOVE A FRYER FILLED WITH HOT LIQUID.</p> <p>II ALWAYS WEAR OIL-PROOF, INSULATED GLOVES WHEN WORKING WITH A FRYER FILLED WITH HOT OIL.</p> <p>III ALWAYS DRAIN HOT OIL INTO A METAL TUB, POT OR CAN ... HOT OIL CAN MELT PLASTIC BUCKETS OR SHATTER GLASS.</p> |
|--|

COMPUTER PANEL KEY DESCRIPTIONS

1. HOLD LAMP
When lit (bright) indicates a product hold time is being tracked.
2. HEAT LAMP
When lit (bright) indicates the computer is calling for heat.
3. DISPLAY
Displays modes, functions and operations of the computer.
4. MELT LAMP
When lit (bright) indicates the computer is in the melt cycle.
5. PROGRAM LAMP
When lit (bright) indicates the computer is in the program mode.
6. ON/OFF KEY
Turns the computer ON and OFF when the fryer power switch is in the ON position and the drain valve lever is in the closed UP position.
7. PROGRAM KEY
 - a. In “operating” mode, allows access to the programming mode.
 - b. In “programming” mode, allows access to the operating mode and general navigation function.
8. SCAN KEY
 - a. In “operating” mode, displays the remaining cook time on every product currently in a cook cycle and lights the respective products “LED” for 2 seconds.
 - b. In “programming” mode, steps to the next function to be programmed.
9. ENTER EXIT FILTER KEY
This key will force a filter the fryer into the filter mode. This key is an optional feature.
10. TEMP/TOGGLE CLEAR KEY
 - a. In “operating” mode, displays the actual temperature followed by the programmed “set” temperature.
 - b. In “programming” mode, allows the user to “toggle” (switch) between choices in an entry field and “clear” values from a data field.
11. HOLD KEY
 - a. In “operating” mode, used to view remaining hold times.
12. SET BACK
 - a. In operating mode forces setback . Display will show “setback” and appliance will be controlled to **setback** temperature instead of **set point** temperature.
13. EXIT/MELT KEY
 - a. In “operating” mode, used to manually exit the shortening melt cycle.
 - b. In “programming” mode, used to enter numerical value 0.
14. PRODUCT LED
 - a. When lit (bright) in the “operating” mode, identifies the product data being displayed.
 - b. When lit (bright) in the “programming” mode, identifies the product being programmed.
15. PROGRAMMING AND PRODUCT COOK KEY
 - a. In “operating” mode, used to start and stop a product’s cook cycle.
 - b. In “programming” mode, used to enter numerical values 1 to 10.

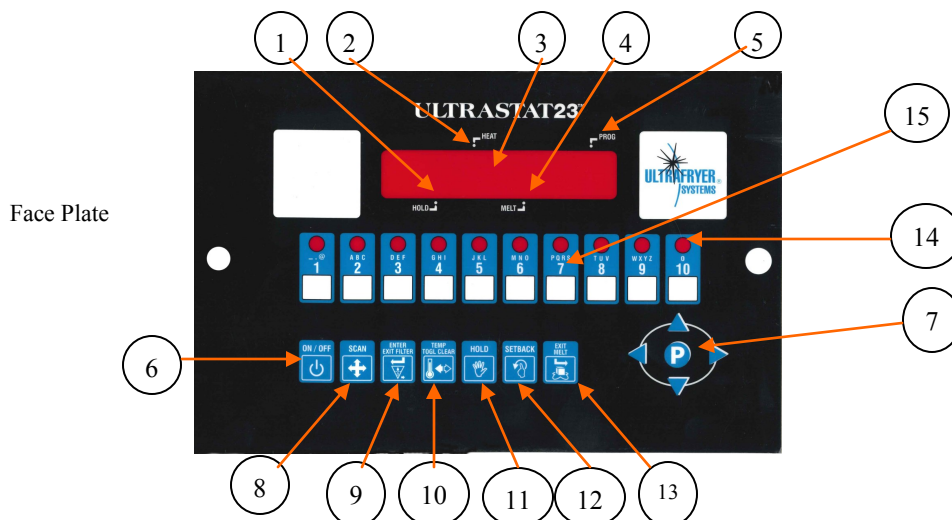



Ultrastat 23 Programming Guide

- 1** Turn Toggle ON/OFF switch to ON position and amber power indicator lamp will illuminate. Then press power ON/OFF key.

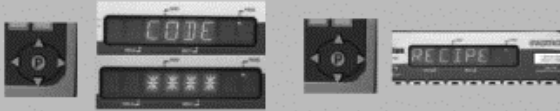

- 2** Push and hold the "P" key for 3 seconds to enter PROGRAMMING MODE. PROGRAM will appear in display.



- 3** Push "P" key the second time to display CODE. Enter "1724" and push the "P" key. RECIPE will display.



- 4** Push "P" key and "PRODUCT" will display. Hit product key you want to program and hit "P" key.



- 5** Display shows "ALL". Push "P" key to program each function and "NAME" appears. To change hit the "DOWN ARROW" and scroll to find the word you want in the library. Then push the "P" key to enter it and go to the next item.



- 6** "TIME 1" will display. To change the time hit "TOGGLE CLEAR" index the time you want on the number pad and press the "P" key to save.



- 7** "TEMP 1" will display. To change hit "TOGGLE CLEAR" and key in the amount you want and hit the "P" key.



- 8** "FLEX" or "STRAIGHT" time will appear. To change from one to the other, hit the left arrow key. Then hit the "P" key to save it.



- 9** Display shows "TIME 2". Repeat steps 6, 7, and 8 for each profile. After the last profile, display will show "ALARM TIME 1".

- 10** To change "ALARM TIME 1" hit "TOGGLE CLEAR" and index what you want on the number keys and hit the "P" key and the display will show "ALARM NAME".

- 11** To change "ALARM NAME" hit "DOWN ARROW" and scroll until you find the name you want. Then hit the "P" key. Repeat for alarm 2 and 3 if applicable.

- 12** Display will show "HOLD TIME 1". For most applications this is not used so exit at this point. To exit press the "DOWN ARROW" key repeatedly until "EXIT" shows on the display. Then hit the "P" key. "PRODUCT" will show on the display.

- 13** Then hit the "UP ARROW" key and display will show "EXIT". Hit the "P" key and display shows "RECIPE". Hit the "UP ARROW" again then hit "P" key and "PREHEAT" or "READY" should appear. You are now out of program mode and ready to operate with the latest changes.



ULTRASTAT 23 START-UP AND COOKING COMPUTER OPERATION

- NOTES:** 1) The computer will keep the fryer in the MELT CYCLE until the EXIT MELT button is manually depressed.
- 2) The computer CANNOT be taken out of the SHORTENING MELT MODE until the shortening temperature reaches the MELT LIMIT TEMPERATURE. The Melt Limit Temperature is factory set for a HIGH exit temperature (135°F / 57°C) or a LOW exit temperature (100°F/38°C).

The following are abbreviated operating procedures for a fryer equipped with an Ultrastat 23 Cooking Computer. The attached Ultrastat 23 Ultrafryer Computer Operating Instructions, Manual PN 30A216, contains DETAILED Operating, Filtering, Boil-Out and Programming Instructions.

1. START-UP and COOKING

Safely start-up a gas fryer equipped with an Ultrastat 23 Cooking computer as follows:

1. ULTRASTAT 23 START-UP - Safely start-up an electric fryer equipped with an Ultrastat 23 Cooking computer as follows:

<u>STEP</u>	<u>ACTION</u>	<u>RESPONSE</u>
1	ENSURE the drain valve lever on the fryer is in the CLOSED position, shortening is at the proper level, then turn the fryer ON/OFF switch to the on position.	A. The AMBER Power lamp beside the ON/OFF switch will LIGHT. B. The heating elements will power up and begin to heat the shortening.



CAUTION: PRIOR TO PROCEEDING TO STEP 2 VISUALLY CHECK THAT THE HEATING ELEMENTS ARE COVERED WITH AT LEAST 2" (51 mm) OF SHORTENING .

2.

2	Turn the Computer ON by depressing the computer ON/OFF button.	A. The MELT lamp will LIGHT to indicate the computer is in the SHORTENING MELT MODE. B. The HEAT lamp on the computer and the RED heat mechanism indicator lamp on the fryer will cycle ON and OFF indicating the heat mechanism is periodically being turned ON and OFF to gently heat the shortening.
3	Once the Melt Limit Temperature is reached depress the EXIT MELT BUTTON on the computer to cancel the SHORTENING MELT MODE.	A. LO will appear in the computer display indicating shortening temperature is more than 10°F (5°C) below the set-point temperature. B. The HEAT lamp on the computer and the RED heat mechanism indicator lamp will remain ON until the set-point temperature is reached.
4	When "Ready" appears in the Computer display indicating the SET-POINT TEMPERATURE of the shortening has been reached, a COOK cycle can be initiated.	A. Stir the shortening several times to ensure that all the shortening has reached the set point temperature.

ULTRASTAT 23 COOKING COMPUTER PROGRAMING

Program the Ultrastat 23 Cooking Computer according to the, Computer Operating Instructions Manual, (PN 30A216) provided with the Fryer.

NOTE

PROGRAMMING OF AN ULTRASTAT 23 COOKING COMPUTER SHOULD ONLY BE PERFORMED BY A STORE MANAGER OR AREA SUPERVISOR.

A. GENERAL COOKING

Most products should be cooked with a shortening temperature about 350°F (177°C); however, each product should be cooked at the **LOWEST** temperature that produces a high quality product while obtaining maximum usage of the shortening.



WARNING

- I – DO USE A HIGH QUALITY SHORTENING TO ACHIEVE A CONSISTENT QUALITY PRODUCT AND LONG TERM SAVINGS**
- II – DO NOT SALT PRODUCTS OVER THE FRYER AS SALT QUICKLY DETERIORATES THE SHORTENING AND FLAVORS OTHER PRODUCTS COOKED IN THE SAME SHORTENING**
- III – DO FILTER SHORTENING AFTER THE LUNCH AND DINNER RUSH AND MORE OFTEN IN A**

NOTE

Startup steps 1, 2, 3, and 4 will have to be repeated each time any of the following occurs:

DRAIN VALVE IS OPEN. FRYER TOGGLE ON/OFF SWITCH IS TURNED OFF TO FILTER SHORTENING OR BOIL-OUT A FRYER. FRYER TOGGLE ON/OFF

When the Computer is taken out of the SHORTENING MELT MODE each morning, shortening in the fryer vat will be heated to its SETPOINT temperature **HEATING** will appear in the display to indicate the shortening temperature is MORE than 20°F (-6.6°C) BELOW the set point temperature. When shortening temperature rises to the SETPOINT temperature, **“READY”** will appear in the display indicating a COOK CYCLE can be started.

B. STARTING A COOK CYCLE

To start a cook cycle simply press the product key for the product you wish to cook. If the product is programmed, the correctly cooking time will be displayed **“3:00”** (example) and this time will immediately start to count down in minutes and seconds. If correctly programmed, it will count down to **“ :00”** followed by a beeping signal. To turn this signal OFF and reset the Computer, press the same product key used to start the COOK CYCLE.

C. CANCELLING A COOK CYCLE

If a cook cycle was inadvertently started it may be cancelled two (2) ways:

- 1) Press and hold the same product key used to start the cook cycle for 4 SECONDS. This prevents an accidental start of a cook cycle while a product is being cooked.
- 2) A cook cycle can be CANCELLED at any time by turning the fryer ON/OFF Switch to the OFF position.

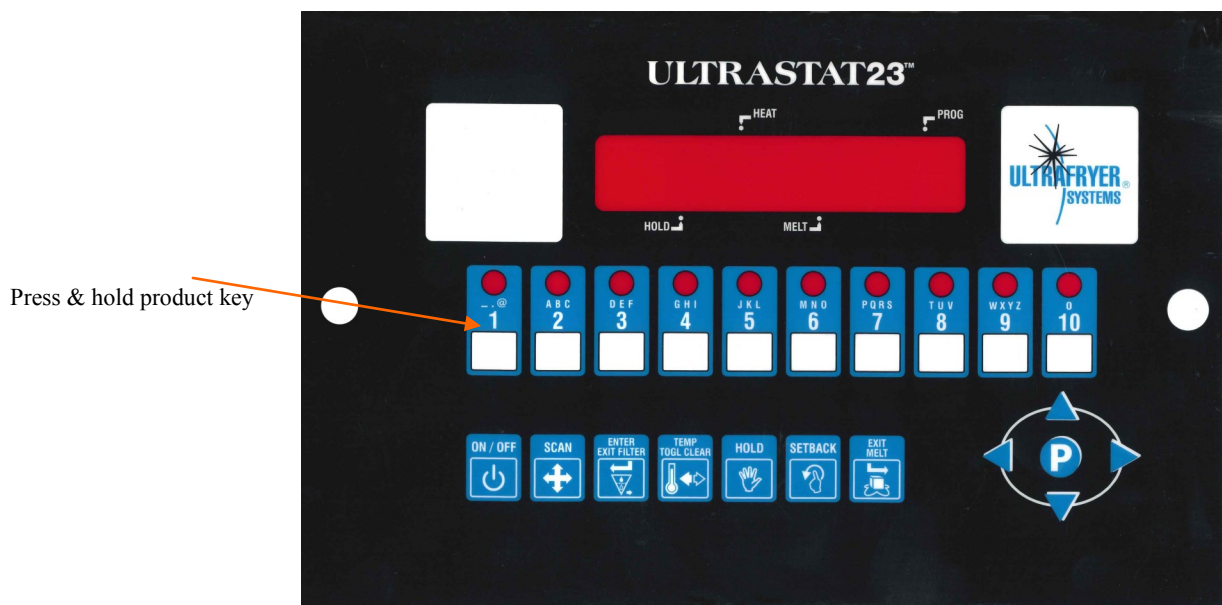

FILTERING INSTRUCTIONS

GENERAL - The Model EUF Electric Fryer is equipped with a Central Filtration System which is located on a Filter Tub Caddy located beneath the left side of the fryer as shown below. The Toggle ON/OFF Switch and AMBER Power Indicator Lamp and RED Heat Mechanism Indicator Lamp are located on the Temperature Control Access Door. The Drain Lever and Filter Lever are located beneath the access door, and other controls are located behind the hinged door.

FILTER TUB ASSEMBLY - The Model EUF Filter Tub Assembly consist of a “Micro-Mesh Stainless Steel Filter” or a “Magnepad Paper Envelope Filter”; and a Filter Tub Handle, Filter Tub Cover, and Filter Tub as well as, a Wash Down Hose Assembly shown to the right.

A. Assemble a clean Filter Screen as follows:

1. “Micro-Mesh” Stainless Steel Filter Screen

- a. Insert the SUCTION FITTING on the BAFFLE in the hole of the UPPER FILTER SCREEN; then place these items on top of the LOWER FILTER SCREEN.
- b. ENSURE all sides of the FILTER SCREEN assembly are aligned, place the PIN end of FRAME A on the FILTER SCREENS, place the CHANNEL on the frame adjacent to the PIN end over the FILTER SCREENS; then HINGE the frame so the edge of the FILTER SCREENS are inserted in the other CHANNEL of FRAME A.
- c. Place the PIN end of FRAME B on the FILTER SCREENS so the PIN is seated in the CHANNEL of FRAME A near the FINGER LOOP, place the CHANNEL on the frame adjacent to the PIN end over the edge of the FILTER SCREENS; then HINGE the frame so the edge of the FILTER SCREENS are inserted in the other CHANNEL of FRAME B and the PIN of FRAME A is seated in the CHANNEL of FRAME B .
- d. Adjust FRAME A and B so both PINS are properly seated in the CHANNEL of the opposite frame; then CAREFULLY connect the KNURL KNOB attached to the STANDPIPE to the SUCTION FITTING on the FILTER SCREEN assembly.

2. “Magnapad Paper Envelope” Filter

- a. Insert the BAFFLE into the FILTER PAD ENVELOPE, when inserted properly the SUCTION FITTING will protrude through the hole in the pad.
- b. Fold FLAP over (in the direction of the hole), securing the Baffle inside the FILTER PAD ENVELOPE.
- c. CAREFULLY, align the CLIP & STANDPIPE ASSEMBLY so that the CLIP can secure the FLAP on the Envelope and the STANDPIPE will align over the SUCTION FITTING protruding through the Envelope.
- d. Tighten the Knurled NUT on the STANDPIPE on the SUCTION FITTING protruding through the Envelope.

FILTERING

1. Turn the Toggle ON/OFF Switch on the fryer vat to be filtered OFF, place 16 ounces (.454 kg) by volume of FILTER AGENT in a 20" (508 mm) and 18" (457 mm) deep fryer vat; 14 ounces (.397 kg) in an 18" (457 mm) SHALLOW fryer vat; and 8 ounces (.227 kg) in a 14" (356 mm) fryer vat; thoroughly stir the filter agent into the shortening using the skimmer, then skim the shortening to remove any floating crumbs.



CAUTION

Be careful of hot metal parts and splashing oil

2. Carefully open the drain valve on the vat to be filtered by turning the DRAIN LEVER slightly downward. When the bottom of the filter tub is covered with about 2" (51 mm) of shortening, OPEN the drain valve and slowly drain shortening to allow the heat mechanism to gradually COOL.
3. When all shortening in the vat has drained into the filter tub, use the DRAIN ROD to stand the wire grill on one side of the vat.
4. Use the drain rod to break up the sediment cake on the bottom of the vat and to pull the sediment toward and into the Drain Valve Opening.
5. Use a scraper to remove encrusted material from the sides of the vat and a scrubbing pad to remove carbon buildup from the top and sides of the heat mechanism.
6. SECURELY connect the Wash Down Hose female QUICK-CONNECT COUPLER to the male QUICK-CONNECT STEM on the rear wall of the vat.
7. Place the Wash Down Hose Nozzle into the fryer and hold it firmly against an inner wall. This prevents the hose from "recoiling upward" when the Filter Pump is turned on.



WARNING

Watch for recoiling wash wand hose when pumping shortening thru hose

8. Turn the FILTER PUMP LEVER to the open (DOWN) position, hold the nozzle at a 45° angle from the bottom of the fryer causing shortening and debris to bounce off the rear wall of the vat and flow towards the drain valve opening.
9. Use the "L" shaped vat brush to push the sediment through the drain valve to keep the drain clear. Hose off the Heat Elements and all walls of the vat until all the shortening and residue at the bottom of the fryer has been flushed through the drain into the filter tub.
10. Turn the FILTER PUMP LEVER to the closed (UP) position, disconnect the Wash Down Hose COUPLER from the STEM on the rear wall of the vat; then hang the wash down hose in an upright position so shortening can drain into a container.
11. Replace the wire grill in the fryer with the SHORTENING DEFLECTOR on the right COVERING the quick-connect stem on the vat.
12. Set a timer for the amount of time established for POLISHING shortening, then turn the FILTER PUMP LEVER to the open (DOWN) position to allow shortening to circulate through the system to POLISH the shortening.

13. At the end of the established time, TURN the FILTER PUMP LEVER, and the DRAIN VALVE LEVER to the closed UP position; then TURN the FILTER PUMP LEVER to the OPEN (DOWN) position to automatically return shortening in the filter tub to the fryer vat.
14. When all shortening in the filter tub has been returned to the fryer, TURN the FILTER PUMP LEVER to the CLOSED (UP) position, check and if necessary add fresh shortening so shortening is level with the applicable shortening level mark on the rear wall of the fryer.
15. Disconnect the suction line hose from the standpipe and Fryer's Bulkhead Suction Coupling; then THOROUGHLY clean the filter tub assembly.

CAUTION



Hoses and couplings contain hot oil. Be careful when disconnecting hoses and couplings from fryer.

C. SHORTENING DISPOSAL/FRYER BOIL-OUT

1. SHORTENING REMOVAL / DISPOSAL - Fryer vats should be BOILED-OUT at least every 7 DAYS to remove carbon build up and other encrusted materials. Fryers with an Ultrastat 23 Cooking Computer with the SHORTENING MANAGEMENT SYSTEM should be BOILED-OUT.
 - a. If the store is equipped with a Shortening Disposal System, remove used shortening from the fryer vat that is CLOSEST to the Shortening Disposal System connector. If the store is NOT equipped with a Shortening Disposal System, remove used shortening from the first fryer vat.
 - b. Assemble the filter Tub as described earlier. Position the filter tub on the FILTER TUB GUIDES beneath the LEFT side of the fryer; then SECURELY connect the Suction Line Hose Assembly to the STANDPIPE on the Filter Screen and the BULKHEAD Suction Coupling on the fryer as shown to the left.
 - c. Turn the TOGGLE ON/OFF SWITCH to the first vat OFF
 - d. Drain shortening from EACH fryer vat as follows:
 1. Carefully open the drain valve by turning the DRAIN LEVER slightly downward. When the bottom of the filter tub is covered with about 2" (51 mm) of shortening, OPEN the drain valve and slowly drain shortening to allow the heat mechanism to gradually COOL.
 2. When all shortening has drained into the filter tub, use the DRAIN ROD to stand the wire grill on one side of the vat.
 3. Use a scraper to remove encrusted material from the sides of the vat and a scrubbing pad to remove carbon buildup from the top and sides of the heat mechanism.
 4. SECURELY connect the Wash Down Hose female QUICK-CONNECT COUPLER to the male QUICK-CONNECT STEM on the rear wall of the vat.
 5. Place the Wash Down Hose Nozzle into the fryer and hold it firmly against an inner wall. This prevents the hose from "recoiling up" when the filter pump is turned on.



WARNING : Watch for recoiling wash wand hose when pumping shortening thru hose

6. Turn the FILTER PUMP LEVER to the open (DOWN) position, hold the nozzle at a 45° angle from the bottom of the fryer causing shortening and debris to bounce off the rear wall of the vat and flow towards the drain valve opening.
7. Use the "L" shaped vat brush to push the sediment through the valve to keep the drain clear. Hose off the burner tubes and walls of the vat until all the shortening and residue at the bottom of the fryer has been flushed through the drain into the filter tub.

8. Turn the FILTER PUMP LEVER to the closed (UP) position, disconnect the Wash Down Hose COUPLER from the STEM on the rear wall of the vat; then hang the wash down hose in an upright position so shortening can drain into a container.
9. Dispose of used shortening as follows:
 - a) Restaurants NOT equipped with a Shortening Disposal System
 1. Connect the Wash Down Hose female QUICK-CONNECT COUPLER to the male QUICK-CONNECT STEM on the rear wall of the vat, place the hose nozzle into a METAL container and hold it firmly against an inner wall.
 2. Turn the FILTER PUMP LEVER to the open (DOWN) position and pump shortening in the filter tub into the metal container.
 3. When all shortening has been pumped into the container, turn the FILTER PUMP LEVER to the closed (UP) position, disconnect the Wash Down Hose COUPLER from the STEM on the rear wall of the vat; then hang the wash down hose in an upright position so shortening can drain into a container.
 4. Remove any sediment from the Micro-Mesh filter screen using the filter tub scraper.

NOTE

Magnapad Paper Filter Assemblies **DO NOT** have to be **SCRAPED**.

5. Repeat steps d 1) through d 9)
 - A. (4) above to remove shortening from each of the remaining vats into metal containers.
 - B. Restaurants EQUIPPED with a Shortening Disposal System
 1. SECURELY connect the Shortening Disposal System Hose fitting to the male QUICK-CONNECT STEM on the rear wall of the vat and connect the fitting on the other end of the hose to the Disposal System connector on the wall.
 2. Turn the **FILTER PUMP LEVER** to the open (**DOWN**) position and pump shortening in the filter tub into the exterior rendering tank.
 3. When all shortening has been pumped into the rendering tank, turn the **FILTER PUMP LEVER** to the closed (**UP**) position, remove any sediment from the Micro-Mesh filter screen using the filter tub scraper.

NOTE

Magnapad Paper Filter Assemblies **DO NOT** have to be **SCRAPED**.

4. Repeat steps d 1) through d 7) above; then, turn the **FILTER PUMP LEVER** to the closed **UP** position.

NOTE

Leave the Shortening Disposal Hose connected to the vat stem and Disposal System connector.

5. Repeat steps 9) b) (1) through 9) b) (3) to remove shortening from all remaining vats to the existing render tanks.
10. When shortening has been removed from all Fryers, **THOROUGHLY** clean and re-assemble the filter tub.

2. FRYER BOIL-OUT

A. **BOIL-OUT** each fryer following cleaning instructions contained in the Cleaning Manual provided by your approved chemical supplier. The following are generic procedures:

1. Ensure all Drain Levers are in the closed (**UP**) position, then add water to each vat until it reaches the “**MIN**” shortening level mark on the rear wall of the vats.
2. Add the amount of **BOIL-OUT COMPOUND** in each fryer vat as prescribed in the Cleaning Manual provided by the Chemical Supplier.
3. Turn the Toggle ON/OFF switch and, if applicable, Manual Gas valve for each fryer vat to the **ON** position; then depress the Computer ON/OFF key to the **ON** position.

4. Place the Computer in the **BOIL MODE**. See computer operation Instruction Manual 30A214 for details instructions.

CAUTION



ONLY USE A “NON-CHLORINE” BOIL-OUT COMPOUND!!!

NOTE

The drain lever must be in the closed **UP** position to turn the computer **ON**.

5. When the boil-out solution reaches **190°F (88°C)** set a timer for 30 minutes. Frequently scrub the sides, front and rear of each fryer vat with a long handled scrub brush.

NOTE



will appear in the Computer display and the Computer will turn the Ultrafryer heat mechanism **ON** and **OFF** to heat and maintain the boil-out solution to **190°F (88°C)**.

6. After the boil-out solution has ‘**BOILED**’ for 30 minutes and the timer sounds press the following computer keys in the order shown to **EXIT BOIL MODE**:
7. Turn the Toggle ON/OFF Switch and, if applicable, the Manual Gas Valve for each fryer to their **OFF** position and **CAREFULLY** dispose of the boil-out solution in each fryer into a floor drain.
8. Use a scrubbing pad to remove carbon buildup from the top of the heat mechanism. To remove carbon build-up on the sides and bottom of the heat mechanism; slide one end of a stropping pad under each section, grasp that end with a pair of tongs, and rock the pad up and down along the length of each section until all encrusted material has been removed.
9. Rinse each fryer with hot water until the water coming out of the drain valve is **clear**.
10. Mix a solution of **ONE PART** vinegar to **25 PARTS** of water. Place this mixture into a one gallon garden pressure sprayer; and **THOROUGHLY** spray this solution onto the **SIDES, HEAT EXCHANGER, and BOTTOM** of each fryer to neutralize the Boil-Out Compound.
11. **THOROUGHLY** wipe the sides, heat mechanism, and bottom of each fryer with clean, lint-free, dry towels to remove any remaining water; then fill each fryer with **NEW** shortening following procedures on page 24 of this manual.



WARNING

Do not use the filter pump to remove water from the vats as this will cause premature pump failure and void the pump warranty.



CAUTION: Boil-Out Compound will cause shortening to break down rapidly if it is not neutralized.

CLEANING - Any item of equipment operates better and lasts longer when it is kept cleaned and properly maintained, and the ULTRAFRYER and FILTER TUB ASSEMBLY are no exception. Clean the FILTER SCREEN after Filtering Shortening and at Closing; and THOROUGHLY clean the FILTER TUB ASSEMBLY each DAY and WEEK as described below.

A. Daily

1. Clean the Filter Tub and Filter Assembly after **FILTERING** and **AT CLOSING** as follows:
 - a. After Filtering Shortening:
 1. Disassemble the Filter Tub by removing the following items in the order listed; (1) **FILTER TUB HANDLE**, (2) **COVER**, (3) **WASH DOWN HOSE**, (4) **SUCTION LINE HOSE**, and (5) **FILTER ASSEMBLY**.
 2. Clean the Suction Line Hose and Wash Down Hose with sanitizer solution; then hang these hoses in an upright position so any shortening can drain into a container.
 3. Raise the Filter Assembly above the Filter Tub and let any sediment or shortening drain into the tub; then **THOROUGHLY** clean the filter assembly as follows:
 - a. “Micro-Mesh” Stainless Steel Filter Screen
 1. **CAREFULLY** remove any debris from the screen using a scraper.
 2. Remove the **STANDPIPE** and **KNURL** knob from the **FILTER SCREEN** assembly, grasp the **FINGER LOOP** on **FRAME A** and adjacent **FINGER LOOP** on **FRAME B**, **EVENLY** pull the frames apart; then **HINGE** FRAME A to remove it from the **FILTER SCREENS FIRST**.
 3. Grasp the **FINGER LOOP** on the straight side of **FRAME B**; then **HINGE** it to remove FRAME B from the **FILTER SCREENS**.
 4. Separate the **UPPER FILTER SCREEN** and **BAFFLE** from the **LOWER FILTER SCREEN**.
 5. **CAREFULLY** clean the two frames, screens and baffle in the 3 compartment sink with hot water and allow these items to air dry. **DO NOT USE SOAP**. If necessary the channels in each frame can be cleaned with the edge of a scotch-brite pad.
 6. Insert the **SUCTION FITTING** on the **BAFFLE** in the hole of the **UPPER FILTER SCREEN**; then place these items on top of the **LOWER FILTER SCREEN**.
 7. **ENSURE** all sides of the **FILTER SCREEN** assembly are aligned, place the **PIN** end of **FRAME A** on the **FILTER SCREENS**, place the **CHANNEL** on the frame adjacent to the **PIN** end over the **FILTER SCREENS**; then **HINGE** the frame so the edge of the **FILTER SCREENS** are inserted in the other **CHANNEL** of **FRAME A**.
 8. Place the **PIN** end of **FRAME B** on the **FILTER SCREENS** so the **PIN** is seated in the **CHANNEL** of **FRAME A** near the **FINGER LOOP**, place the **CHANNEL** on the frame adjacent to the **PIN** end over the edge of the **FILTER SCREENS**; then **HINGE** the frame so the edge of the **FILTER SCREENS** are inserted in the other **CHANNEL** of **FRAME B** and the **PIN** of **FRAME A** is seated in the **CHANNEL** of **FRAME B**.
 9. Adjust **FRAME A** and **B** so both **PINS** are properly seated in the **CHANNEL** of the opposite frame; then **CAREFULLY** connect the **KNURL KNOB** and **STANDPIPE** to the **SUCTION FITTING** on the **FILTER SCREEN** assembly. **DO NOT OVERTIGHTEN!!!**
 - A. “Magnepad Paper Envelope” Filter: Magnepad Paper Filter Assemblies **DO NOT** have to be **SCRAPED** after filtering shortening.
 4. Remove any sediment and shortening in the Filter Tub using a scraper; then wipe the tub dry with paper towels.
 5. Carefully insert the Filter Assembly in the bottom of the Filter Tub with the **STANDPIPE** centered in the handle end of the tub.



CAUTION

WHEN ASSEMBLED, ENSURE THERE ARE NO FINGER LOOPS ON THE STANDPIPE SIDE OF THE FILTER.

6. Install the assembled Filter Tub Assembly on the filter tub guides beneath the fryer; then **SECURELY** connect the Suction Hose Assembly to the **STANDPIPE** on the Filter Screen and the **BULK-HEAD SUCTION COUPLING** on the Fryer as shown to the right.

B. At Closing

1. Repeat **DAILY** steps A 1 a 1) thru A 1 a 3) above.
2. **THOROUGHLY** clean the Filter Assembly as follows:
 - a. “Micro-Mesh” s/s Filter Screen:
 1. **THOROUGHLY** flush any remaining sediment from both sides of the filter screen with **HOT WATER**.
 2. Remove the **STANDPIPE** and **KNURL** knob from the **FILTER SCREEN** assembly, grasp the **FINGER LOOP** on **FRAME A** and adjacent **FINGER LOOP** on **FRAME B**, **EVENLY** pull the frames apart; then **HINGE FRAME A** to remove it from the **FILTER SCREENS FIRST**.
 3. Grasp the **FINGER LOOP** on the straight side of **FRAME B**; then **HINGE** it to remove **FRAME B** from the **FILTER SCREENS**.
 4. Separate the **UPPER FILTER SCREEN** and **BAFFLE** from the **LOWER FILTER SCREEN**.
 5. **CAREFULLY** clean the two frames, screens and baffle in the 3 compartment sink with hot water and allow these items to air dry. **DO NOT USE SOAP**. If necessary the channels in each frame can be cleaned with the edge of a scotch-brite pad.
 6. Insert the **SUCTION FITTING** on the **BAFFLE** in the hole of the **UPPER FILTER SCREEN**; then place these items on top of the **LOWER FILTER SCREEN**.
 7. **ENSURE** all sides of the **FILTER SCREEN** assembly are aligned, place the **PIN** end of **FRAME A** on the **FILTER SCREENS**, place the **CHANNEL** on the frame adjacent to the **PIN** end over the **FILTER SCREENS**; then **HINGE** the frame so the edge of the **FILTER SCREENS** are inserted in the other **CHANNEL** of **FRAME A**.
 8. Place the **PIN** end of **FRAME B** on the **FILTER SCREENS** so the **PIN** is seated in the **CHANNEL** of **FRAME A** near the **FINGER LOOP**, place the **CHANNEL** on the frame adjacent to the **PIN** end over the edge of the **FILTER SCREENS**; then **HINGE** the frame so the edge of the **FILTER SCREENS** are inserted in the other **CHANNEL** of **FRAME B** and the **PIN** on **FRAME B** is seated in the **CHANNEL** of **FRAME A**.
 9. Adjust **FRAME A** and **B** so other **PINS** are properly seated in the **CHANNEL** of the opposite frame; then **CAREFULLY** connect the **KNURL KNOB** and **STANDPIPE** to the **SUCTION FITTING** on the **FILTER SCREEN** assembly. **DO NOT OVERTIGHTEN!!!**
 10. “Magnepad” Envelope Filter - Remove and discard the **USED** Filter Pad Envelope, **CAREFULLY** clean the Baffle Assembly and Clip / Standpipe Assembly in the 3 compartment sink with **HOT** water and allow these items to air dry. **DO NOT USE SOAP!!** Re-assemble the Magnepad Envelope Filter using a **NEW** Filter Pad Envelope as follows:
 1. Insert the **BAFFLE** into the **FILTER PAD ENVELOPE**, when inserted properly the **SUCTION FITTING** will protrude through the hole in the pad.
 2. Fold **FLAP** over (in the direction of the hole), securing the Baffle inside the **FILTER PAD ENVELOPE**.
 3. **CAREFULLY**, align the **CLIP & STANDPIPE ASSEMBLY** so that the **CLIP** can secure the **FLAP** on the Envelope and the **STANDPIPE** will align over the **SUCTION FITTING** protruding through the Envelope.
 4. Tighten the knurled **NUT** on the **STANDPIPE** to the **SUCTION FITTING** protruding through the Envelope.
3. Repeat **DAILY** steps A1 a 4) through steps A1 a 6) page 30.

C. WEEKLY

1. Perform the daily cleaning steps A 1 a 1) through A 1 a 3) above.
2. Clean the Filter Assembly as follows:
 - a. “Micro-Mesh” stainless steel filter screen:
 1. Disassemble the filter according to **DAILY** steps A 1 a 3) a) (1) through A 1 a 3) a) (4) and clean the two (2) frames as described in step A 1 a 3) a) (5).
 2. Place the upper and lower **FILTER SCREENS** in the fryer with **BOIL-OUT SOLUTION** for cleaning. **DO NOT PLACE THE BAFFLE OR STANDPIPE IN THIS SOLUTION!!! BOIL-OUT** the fryer vat according to instructions contained in the cleaning manual provided by your chemical supplier.
 3. After the filter screens have been cleaned in the Boil-Out Solution, **ENSURE** they are **THOROUGHLY** sprayed with a solution of **1 PART** vinegar to **25 PARTS** of water to **NEUTRALIZE** the boil-out solution, then allow the screens to air dry. **NOTE:** any residue of boil-out solution on the filter screens could cause the rapid break-down of the shortening.
 4. Reassemble the “Micro-Mesh stainless steel filter screen according to **DAILY** steps A 1 a 3) a) (6) through A 1 a 3) a) (9).
 - b. “Magnepad” Envelope Filter - Disassemble, clean, and re-assemble the “Magnepad” Filter Assembly according to **DAILY** cleaning steps A 1 b 2) b) above.
3. **THOROUGHLY** clean the Filter Tub and Cover with **HOT SANITIZER SOLUTION** and allow them to air dry.
4. Re-assemble the Filter Tub according to **DAILY** steps A 1 a 5) and A 1 a 6) .



CAUTION

WHEN ASSEMBLED, ENSURE THERE ARE NO FINGER LOOPS ON THE STANDPIPE SIDE OF THE MICRO-MESH FILTER.

**PREVENTATIVE MAINTENANCE
AND TROUBLESHOOTING**



WARNING

ENSURE REPAIRMEN ARE ADVISED THAT FRYER RESTRAINTS MUST BE DISCONNECTED/CONNECTED IF A FRYER IS TO BE MOVED DURING MAINTENANCE OR REPAIR AND THAT ELECTRICAL POWER AND/OR GAS MUST BE TURNED OFF PRIOR TO PERFORMING ANY MAINTENANCE OR REPAIR.

PREVENTIVE MAINTENANCE

Minimal maintenance is required on a fryer because of its design and materials used in manufacture. However, some preventive maintenance and inspection must be performed periodically to prevent break downs which

could curtail food sales. Any preventive maintenance or inspection should be accomplished with **CAUTION**

while the fryer is in operation since **HOT** liquid shortening could cause severe burns. If service or repair is required, all electrical power **MUST BE TURNED OFF PRIOR TO** performing that service or repair.

PREVENTIVE MAINTENANCE SCHEDULE

DAILY

ITEM

INSPECT FOR:

Grease Filters

Clean grease filters in the exhaust hood each evening and allow them to dry overnight. Thoroughly clean the filter tub assembly as prescribed on page 34 of the Cleaning Section of this manual.

Filter Tub

ENSURE THE WASH DOWN HOSE IS HUNG IN AN UPRIGHT POSITION (BY ONE END) SO SHORTENING CAN DRAIN INTO A CONTAINER

WEEKLY

Drain/Filter Pump Valve Levers

Determine that the drain and pump levers are securely attached to the drain and pump valves, and that the valves can be easily opened and closed.

Drain Hoses

Inspect the suction line hose, wash down hose and if applicable the shortening disposal hose for any evidence of deterioration.

Plumbing Heat Tape Insulation

Ensure that insulation and electric heat tape wrapped around the plumbing directly behind the drain trough has not been damaged.

Temperature Sensing Probes

During boil-out of the fryer, inspect the temperature and high limit sensing probes for any visual damage.

TROUBLESHOOTING

A. GENERAL: The problems and possible solutions listed in the troubleshooting chart below are typical Problems that

are frequently encountered. **ONLY** qualified repairmen are to use the troubleshooting chart to repair this fryer. In the event an electrical malfunction occurs, perform the following checks **PRIOR** to contacting a repairman:

1. Ensure high voltage circuit breakers are in their proper position.
2. Check that the fryer electrical plug is connected to an electrical receptacle.
3. Ensure the applicable Circuit Breaker is in the **ON** position and that the Toggle ON/OFF Switch is in the **ON** position, and computer is "Powering Up".

B TROUBLESHOOTING CHART: Should a problem occur that cannot be corrected after performing the above **CHECKS**, contact an authorized repairman and/or Greenfield World Trade (954) 202-7336 and provide the information acquired while performing these checks.

SERVICE AND PARTS

TECHNICAL ASSISTANCE AND PARTS ORDERING INFORMATION

1. **TECHNICAL ASSISTANCE** - Contact an authorized service agent or the Customer Service Department, Ultrafryer Systems at 1-800-525-8130 for technical assistance.
E-Mail technical assistance at: techserv@ultrafryer.com

2. ORDERING INFORMATION:

- A. **REPLACEMENT PARTS** - Provide the following information when ordering replacement parts by phone, fax or mail:

Your company name and phone number
Your company purchase order number
Bill-to address
Ship-to address
Quantity desired
Part number and description of the desired-item Your name or signature of authorized-buyer

Phone in order to: 954-202-7336

FAX order to: 954-202-7337

Mail order to: Greenfield World Trade
U.S. Office
3355 Enterprise Ave. Suite 160
Ft. Lauderdale, FL 33331

Website: www.Greenfieldworld.com

3. **DAMAGES** - Ultrafryer Systems is not responsible for damage occurring in transit. All deliveries must be inspected for damage to shipping containers prior to departure of the delivering carrier. Any damage must be stated on the receiving document to facilitate filing of freight claims. Carriers must be notified immediately and freight inspections must be requested from the carrier. Ultrafryer Systems can and will gladly assist you in preparing and processing of the necessary claims only if proper notification has been accomplished on the carrier delivery document. Damaged equipment and or containers must be available for the claims inspector to inspect.

ITEM	DESCRIPTION	PN
1	2" (51mm) Drain Valve for EUF - 18/20" Electric Fryers (Uses Gasket PN 22A119).	12775
	1 1/4" (32mm) Drain Valve for EUF - 14" Electric Fryers (Uses Gasket PN 22A119).	12A483
2	Drain Clean-out Rod.	12569
	Filter Valve Lever for EUF-14" Electric Fryer.	12A476
3	Filter Valve Lever for EUF-18" Electric Fryer.	12A477
	Filter Valve Lever for EUF-20" Electric Fryer.	12A477
4	Drain Ball Valve Lever for EUF-14 Electric Fryer.	12A476
	Drain Ball Valve Lever for EUF-18/20 Electric Fryer	12A477
5	Heat Element Teflon Washer.	18-174
6	3 Pole, 60 Ampere Mechanical Contactor	18A100
7	Computer, Cook U23 Basic Fast Meridian	22A436
8	Temperature Sensing Probe (Used with Ultrastat Cooking Computers)	18A006
9	Type K Step Down 100 KVA Square D Step Down Transformer	22707
	208 Volt, 3 Ø, 8.5 KW Heat Element for EUF-14 Electric Fryer.	18A012
10	208 Volt, 3 Ø, 10 KW Heat Element for EUF-18/20 Electric Fryer.	18A013
	240 Volt, 3 Ø, 8.5 KW Heat Element for EUF-14 Electric Fryer	18A014
	240 Volt, 3 Ø, 10 KW Heat Element for EUF-18/20 Electric Fryer.	18A015
11	Drain Valve Lever Microswitch mounting bracket for all EUF Electric Fryers.	19A104
	Heat Element Support Bracket for all EUF-18 Electric Fryer.	19A117
12	Heat Element Support Bracket for all EUF-20 Electric Fryer.	19A118
	Heat Element Support Bracket for all EUF-14 Electric Fryer.	19A178
13	Hi-Limit Switch Pre-Set to trip at 450° F (232°C) for all EUF-18/20 Electric Fryers (NOTE1).	22543
	Hi-Limit Switch Pre-Set to trip at 435° F (224°C) for all EUF-14 Electric Fryers (NOTE1).	19A193
14	Hi-Limit Switch Probe Holder for all EUF Electric Fryers.	19A788
	Basket Hanger Bracket for all EUF-14 Electric Fryer.	19A949
15	Basket Hanger Bracket for all EUF-18 Electric Fryer.	19A950
	Basket Hanger Bracket for all EUF-20 Electric Fryer.	19A951
16	Hi-Voltage Terminal Block for all EUF Electric Fryers.	22-544
	19 1/4" x 19 1/4" (489 mm x 489 mm) Vat Grill with Deflector for EUF-20 Electric Fryer.	12A071
17	13 1/4" x 13 1/4" (337 mm x 337 mm) Vat Grill with Deflector for EUF-14 Electric Fryer.	12A070
	17 1/4" x 17 1/4" (438 mm x 438 mm) Vat Grill with Deflector for EUF-18 Electric Fryer.	12A062
18	Hexagon Neoprene Pump/Motor Bushing for all EUF Electric Fryers.	22-769
19	Power Cord with Molded Plug (Schuko CEE7-7 Type F)	23A303
20	240 Volt 75 Watt Silicon Rubber Heater Tape 5' (1352 mm) for all EUF Electric Fryers.	23-401
21	Type AP-2 Fuse Holder Assembly for all EUF Electric Fryers.	23-373
22	Buss Type AGC-8 8 Ampere Fuse for all EUF Electric Fryers.	23-374
23	Filter System Ball Valve for all EUF Electric Fryers 1/2" (13mm)	24-036
24	Model GPV-0519 7.7 GPM (29.26 LPM) Viking Pump/Motor for all EU 18" & 20" Fryers.	24A036
25	Medium Duty 4" (102mm) Front Caster w/Brake for all EUF Electric Fryers.	28-015
26	Medium Duty 4" (102mm) Rear Caster w/o Brake for all EUF Electric Fryers.	28-016
27	"L" Shaped Tip cleaning Brush for all EUF Electric Fryers.	29A044
28	Switch, Micro Crouzet (#831060C3.AL	18A064
29	Surge Protector 3 Phase OKAYA R.A.V. - 781BXZ-4	23a148
NOTE: 1) Order a 1/4" (6 mm) Compression Fitting PN 24-247 when ordering this item.		
30	Filtration Assy, R-SM-RUL-Permf-G6A (6in)	12C889
31	Filtration Assy, R-LB-RUT-Permf-G6A	11B707
32	230/240 VAC 50/60 MHz motor for 14" fryer 5.5 GPM (19.25 LPM) pump	24A206 24329

WIRING DIAGRAMS

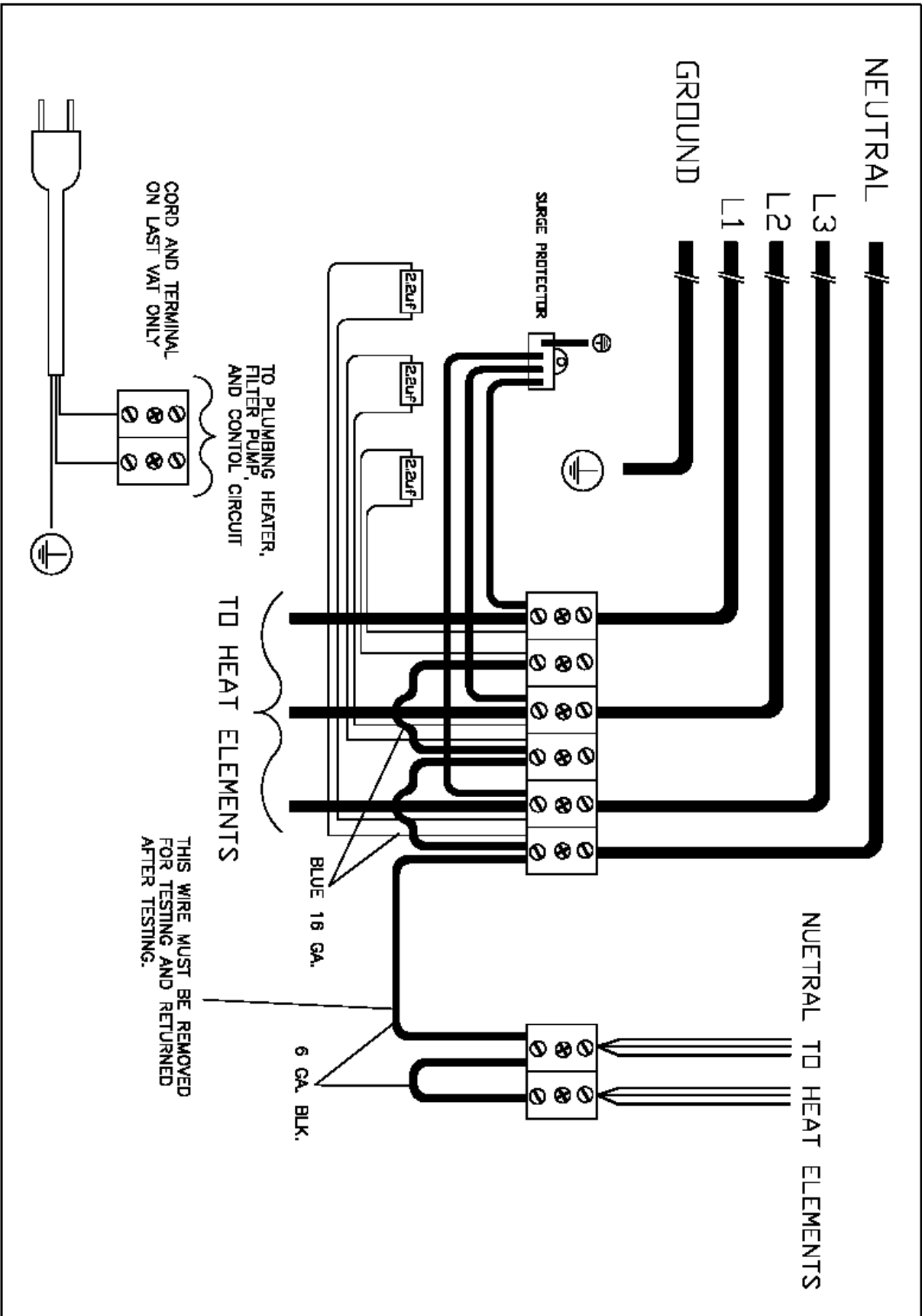

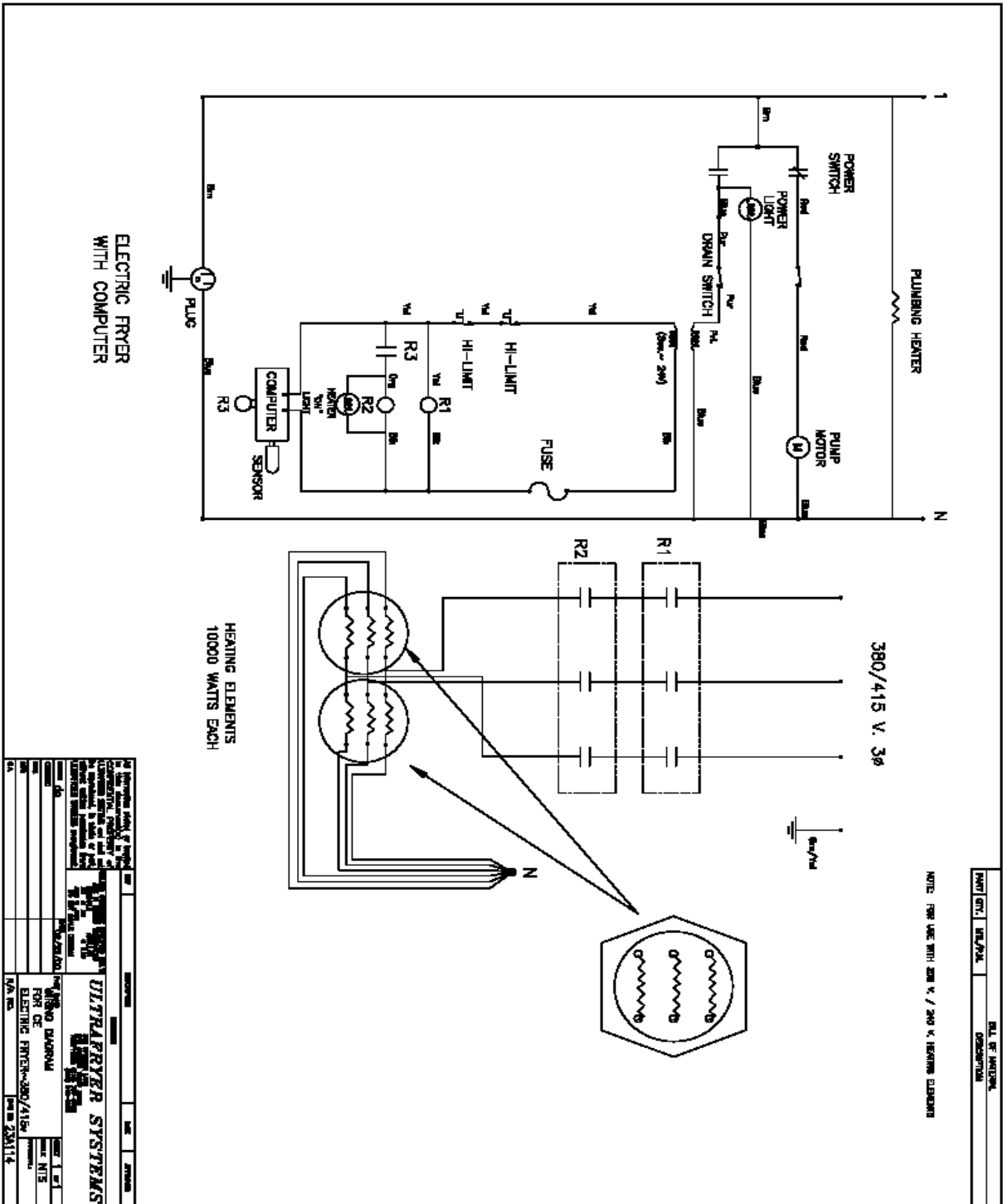

REV	DESCRIPTION	DATE	BY	CHKD
01	REVISED TO ADD 208V/240V HEATING ELEMENTS	03/11/14	WJ	WJ
02	REVISED TO ADD 10000W HEATING ELEMENTS	03/11/14	WJ	WJ
03	REVISED TO ADD 380/415V SUPPLY	03/11/14	WJ	WJ
04	REVISED TO ADD 10000W HEATING ELEMENTS	03/11/14	WJ	WJ
05	REVISED TO ADD 380/415V SUPPLY	03/11/14	WJ	WJ
06	REVISED TO ADD 10000W HEATING ELEMENTS	03/11/14	WJ	WJ
07	REVISED TO ADD 380/415V SUPPLY	03/11/14	WJ	WJ
08	REVISED TO ADD 10000W HEATING ELEMENTS	03/11/14	WJ	WJ
09	REVISED TO ADD 380/415V SUPPLY	03/11/14	WJ	WJ
10	REVISED TO ADD 10000W HEATING ELEMENTS	03/11/14	WJ	WJ

ULTRAFRYER SYSTEMS

FOR THE FRYER

FOR ICE

ELECTRIC FRYER-380/415V

REV. 1.0

REV. N13

REV. 23X11.4