



**Model F-IRD-14  
Operation Instructions**



<p><b>FOR YOUR SAFETY</b></p> <p>Do not store or use gasoline or other flammable vapors or liquids in the vicinity of this or any other appliance. Indoor use only.</p> <p>Purchaser to post in a prominent location instructions to be followed in the event the user smell gas.</p> <p>This information shall be obtained by consulting the local gas supplier.</p>	<p><b>WARNING</b></p> <p>Improper installation, adjustment, alteration, service, or maintenance can cause property damage, injury, or death. Read the installation, operating, and maintenance instructions thoroughly before installing or servicing this equipment.</p>
---	---

302 Spencer Lane • P.O. Box 5369, San Antonio, Texas 78201  
 (800) 525-8130 • (210) 731-5000 • Fax: (210) 731-5099  
[www.ultrafryer.com](http://www.ultrafryer.com)

## PREFACE

This manual was written and published by the Ultrafryer Systems Engineering Department for use by personnel who will operate a Model F-IRD-14 Premix Gas Fryer in a commercial cooking environment. Proper use of a manual will allow store employees to operate, clean, and maintain equipment properly, thereby reducing service call expenses.

**This appliance is intended for professional use and is to be operated by qualified personnel.**

**This manual is to be retained for future reference.**

Throughout this manual, **NOTES**, **CAUTIONS**, **WARNINGS** and **DANGERS** are used to alert the operator to items of special circumstances.

These items are identified as follows:

### NOTE:

**Test Start-Up. Operation, Cooking Filtering and Boil-Out Procedures of a 14" Model IRD Premix Gas Fryer in the manual are based on the Ultrastat 402 Cooking Computer.  
Refer to Manual P/N 30A286 to perform these functions in a fryer equipped with this controller.**

### CAUTION:



**TO ASSURE PRODUCING A QUALITY PRODUCT WHILE PROLONGING THE LIFE EXPECTANCY OF THE FRYER, ENSURE THAT THE BOIL-OUT AND CLEANING INSTRUCTIONS ARE STRICTLY FOLLOWED.**

### WARNING:



**DO NOT ALLOW ANY CLEANING SOLUTION OR WATER TO SPLASH INTO A VESSEL OF HOT COOKING OIL, AS IT WILL CONTAMINATE THE OIL AND MAY CAUSE THE OIL TO SPLATTER CAUSING SEVERE BURNS.**

### DANGER:



**THE FRYER MUST BE CONNECTED ONLY TO THE TYPE OF GAS IDENTIFICATION ON THE RATING PLATE !**

### NOTE:

**This manual is intended as a guide for all Model F-IRD-14 Premix Gas Fryers, regardless of configuration and controllers. It is to be used in conjunction with the applicable controller manual that is included with the fryer.**

# TABLE OF CONTENTS

<b>1. GENERAL INFORMATION.....</b>	<b>5</b>
1.1. DESCRIPTION .....	5
1.2. SAFETY .....	5
1.3. AUTOMATIC SAFETY FEATURES.....	5
1.4. SPECIFICATIONS.....	6
1.5. RATING PLATE.....	6
1.6. INLET GAS LINE SIZING .....	7
1.7. FLEXIBLE GAS LINE LENGTHS .....	8
<b>2. PRE-INSTALLATION .....</b>	<b>8</b>
2.1. GENERAL.....	8
2.2. STANDARDS.....	9
2.3. AIR SUPPLY AND VENTILATION.....	9
<b>3. RECEIVING AND INSTALLING .....</b>	<b>10</b>
3.1. UNPACKING .....	10
3.2. INSTALLING.....	10
3.3. LEVELING .....	10
3.4. GAS CONNECTION .....	11
3.5. ELECTRICAL CONNECTION .....	13
<b>4. ULTRASTAT 402 COOKING COMPUTER.....</b>	<b>13</b>
4.1. THE ULTRASTAT 402 COOKING COMPUTER .....	13
4.2. COMPUTER PANEL KEY DESCRIPTIONS.....	14
4.3. ULTRASTAT 402 PROGRAMMING GUIDE.....	16
4.4. ULTRASTAT 402 START-UP AND COOKING COMPUTER OPERATION .....	17
4.5. GENERAL COOKING .....	18
4.6. STARTING A COOK CYCLE.....	19
4.7. CANCELLING A COOK CYCLE .....	19
<b>5. CLEANING .....</b>	<b>20</b>
5.1. GENERAL CLEANING .....	20
<b>6. PREVENTIVE MAINTENANCE AND TROUBLESHOOTING .....</b>	<b>20</b>
6.1. PREVENTIVE MAINTENANCE .....	20
6.2. TROUBLESHOOTING .....	21
<b>7. TECHNICAL ASSISTANCE, WARRANTY PARTS &amp; REPLACEMENT PARTS ASSISTANCE ....</b>	<b>23</b>
7.1. TECHNICAL ASSISTANCE.....	23
7.2. WARRANTY PARTS .....	23
7.3. REPLACEMENT PARTS .....	23

**8. RECOMMENDED SPARE PARTS..... 23**

8.1. RECOMMENDED SPARE PARTS ..... 23

**9. PARTS IDENTIFICATION ..... 24**

9.1. IRD -14 - CONTROL PANEL ..... 24

9.2. INSIDE ELECTRICAL BOX ASSEMBLY..... 25

9.3. CABINET FRONT VIEW ..... 26

9.4. CABINET REAR VIEW..... 27

9.5. CABINET SIDE VIEW ..... 28

**10. SERVICE PROCEDURES AND ADJUSTMENTS..... 29**

10.1. HARMONIC TONE ..... 29

10.2. GAS VALVE ..... 29

10.3. MODULATING GAS VALVE ADJUSTMENTS ..... 29

10.4. TEMPERATURE PROBE SETTING ..... 30

10.5. HI LIMIT PROBE SETTING ..... 30

10.6. INFRARED BURNER SPARK IGNITOR AND FLAME SENSOR SETTING ..... 31

10.7. GROUND ROD GROUND WIRE CONNECTION ..... 31

10.8. CONTROL, 24 VAC UNIVERSAL GAS BLOWER (PWM) SETTINGS..... 32

**11. LADDER DIAGRAM ..... 33**

11.1. LADDER DIAGRAM..... 33

11.2. SCHEMATIC DIAGRAM..... 34

## 1. GENERAL INFORMATION

### 1.1. DESCRIPTION

The Ultrafryer 14" (355mm) IRD premix gas fryer was designed by Ultrafryer Systems® to operate as an energy-efficient, gas-fired and is design-certified by the Canadian Standards Association (CSA) and the National Sanitation Foundation (NSF). It is manufactured to operate on either NATURAL or PROPANE gas according to the following Operational Requirements. Each fryer is shipped completely assembled with the accessories packed inside the fryer vat and each fryer has been adjusted, tested and inspected prior to shipment. This gas fryer is designed to be used in a commercial food preparation environment after it is properly installed as outlined in this manual.

### 1.2. SAFETY

The major safety concern associated with the Ultrafryer Premix Gas fryer are burns from hot shortening. In order to prevent serious burns, good housekeeping habits are required. The floor in front of and the area around the fryer should be kept clean and dry. Whenever anything is placed into a fryer vat, care should be used not to splash the hot shortening. Product should always be "PLACED" into the shortening, NOT THROWN. Safety goggles, neoprene insulated gloves, and an apron must be worn while boiling-out a fryer vat.

Electrical controls used in the gas fryer operate on 120 volts single phase electrical power, and no adjustments or replacement of electrical controls should ever be attempted without first disconnecting electrical power. The fryer should never be operated with wet hands or while standing in water. To do so can result in serious electrical shock or death.

### 1.3. AUTOMATIC SAFETY FEATURES

**This fryer is equipped with the following Automatic Safety Features:**

1. High Limit thermostat to shut off gas to the main burners by operating a solenoid-activated safety valve in the combination gas control valve if shortening temperature exceeds 400°F (204°C).
2. Combination gas control valve which includes a built-in pressure regulator.
3. Air pressure switch to open the 24volt electrical circuit to the gas control valve, which turns gas to the fryer OFF if a blower motor becomes inoperable.
4. Sensing Circuit within the spark ignitor module to turn gas OFF if a burner FLAME OUT occurs.
5. A current sensor and air pressure switch, combined provide an air proof system for the fryer.

**1.4. SPECIFICATIONS**

MODEL 14" (355mm) IRD PREMIX GAS FRYER OPERATIONAL EQUIREMENTS.

<u>SPECIFICATION ITEM</u>	<b>IRD - 14"</b>
Overall Width	14.875" (378mm)
Overall Depth	34.23" (869mm)
Work Height	34.95" (888mm)
Oil Capacity High Level	58 lbs. (26.3 liters)
Vat Container Size	14.00"x14.00" (355mmx355mm)
Gas Pressure (inlet to fryer)	
Natural Gas	7" (178mm) W.C.
Propane	14" (280mm) W.C.
Gas Rating	
Natural Gas	100,000 BTU/hr (105.43 MJ/HR)
Propane	100,000 BTU/hr (105.43 MJ/HR)
Power Input	120 Volt, 15 Amps, 60Hz, 1 Phase

FT<sup>3</sup>/HR (M<sup>3</sup>/HR) VALUES May vary due to heating value and specific gravity of gas supplied by local Gas Company.

**NOTE:**

**Test Start-Up. Operation, Cooking Filtering and Boil-Out Procedures of a 14" Model IRD Premix Gas Fryer in the manual are based on the Ultrastat 402 Cooking Computer.**  
**Refer to Manual P/N 30A286 to perform these functions in a fryer equipped with this controller.**

**1.5. RATING PLATE**

The rating plate is located on the inside of the Service Access door and contains the following information: the model and serial numbers, BTU/HR input rating of the burners, gas manifold pressure in inches W.C., minimum inlet gas required and gas type. This data is essential for proper identification when communication with ULTRAFRYER SYSTEMS or requesting special parts or information.

**DANGER:**



**THE FRYER MUST BE CONNECTED ONLY TO THE TYPE OF GAS IDENTIFICATION ON THE RATING PLATE !**

**1.6. INLET GAS LINE SIZING**

INLET GAS LINE SIZING - The Table below is to be utilized to calculate the size (diameter) of the inlet gas line from the building regulator to the fryer manifold.

INLET GAS LINE REQUIREMENTS									
PIPE LENGTH	PIPE DIAMETERS (inches & (mm equivalents))								
	Maximum Allowable Flow (Shown in ft <sup>3</sup> /hr (M3/hr))								
Feet (Meters)	½" (13mm)	¾" (19mm)	1" (25mm)	1¼" (32mm)	1½" (38mm)	2" (51mm)	2½" (64mm)	3" (76mm)	4" (102mm)
15 (4.6)	62 (1.7)	108 (4.7)	350 (9.8)	620 (17.4)	960 (26.9)	2,000 (56.0)	3,500 (98.0)	5,400 (151.2)	11,200 (313.6)
30 (9.1)	43 (1.2)	120 (3.4)	245 (6.9)	430 (12.0)	680 (19.0)	1,400 (39.2)	2,450 (68.6)	3,800 (106.4)	7,900 (221.2)
45 (13.7)	35 (1.0)	98 (2.7)	200 (5.6)	355 (9.9)	530 (14.8)	1,150 (32.2)	2,000 (56.0)	3,200 (89.6)	7,900 (182.0)
60 (18.3)	30 (0.8)	84 (2.4)	175 (4.9)	310 (8.7)	480 (13.4)	1,000 (28.0)	1,760 (49.3)	2,700 (75.6)	5,600 (156.8)
75 (22.9)	27 (0.8)	76 (2.1)	155 (4.3)	275 (7.7)	430 (12.0)	890 (24.9)	1,560 (43.7)	2,450 (68.6)	5,000 (140.0)
90 (27.4)	25 (0.7)	70 (2.0)	145 (4.1)	250 (7.0)	395 (11.1)	810 (22.7)	1,430 (40.0)	2,260 (63.3)	4,550 (127.4)
105 (32.0)	23 (0.6)	64 (1.8)	132 (3.7)	232 (6.5)	370 (10.4)	750 (21.0)	1,300 (36.4)	2,100 (58.8)	4,200 (117.6)
120 (36.6)	21 (0.6)	60 (1.7)	125 (3.5)	215 (6.0)	340 (9.5)	700 (19.6)	1,200 (33.6)	1,950 (54.6)	4,000 (112.0)
150 (45.7)	19 (0.5)	54 (1.5)	110 (3.1)	195 (5.5)	310 (8.7)	630 (17.6)	1,080 (30.2)	1,750 (49.0)	3,550 (99.4)
180 (54.9)	17 (0.5)	49 (1.4)	100 (2.8)	175 (4.9)	280 (7.8)	570 (16.0)	960 (26.9)	1,600 (44.8)	3,200 (89.6)
210 (64.0)	16 (0.4)	44 (1.2)	94 (2.6)	165 (4.6)	260 (7.3)	530 (14.8)	890 (24.9)	1,450 (40.6)	3,000 (84.0)
240 (73.2)	15 (0.4)	43 (1.2)	88 (2.5)	155 (4.3)	240 (6.7)	500 (14.0)	840 (23.5)	1,350 (37.8)	2,800 (78.4)
270 (82.3)	14 (0.4)	40 (1.1)	83 (2.3)	145 (4.1)	230 (6.4)	470 (13.2)	780 (21.8)	1,300 (36.4)	2,650 (74.2)
300 (91.4)	14 (0.4)	38 (1.1)	79 (2.2)	138 (3.9)	215 (6.0)	440 (12.3)	750 (21.0)	1,250 (35.0)	2,500 (70.0)
450 (137.2)	11 (0.3)	31 (0.9)	64 (1.8)	112 (3.1)	176 (4.9)	360 (10.1)	630 (17.6)	1,000 (28.0)	2,050 (57.4)
600 (182.9)	10 (0.3)	27 (0.8)	56 (1.6)	97 (2.7)	152 (4.3)	315 (8.8)	530 (14.8)	860 (24.1)	1,750 (49.0)

**NOTE:**

1. FT<sup>3</sup>/HR (M<sup>3</sup>/HR) values may vary due to heating value and specific gravity of gas supplied by local companies.
2. To determine the inlet gas line diameter for the distance between the fryer and main gas regulator, locate the FT<sup>3</sup>/HR (M<sup>3</sup>/HR) of gas required for the fryer and pipe length and read the pipe diameter on the top row. For example: a bank of fryers containing three (3) Par-3-14 fryer operating on Natural gas requires 257.13 FT<sup>3</sup>/HR (7.29 M<sup>3</sup>/HR) <3x85.71 (2.43)>. If the fryer bank is located 60 feet from the building gas regulator, a 1¼" (32mm) diameter gas line MUST be installed between the fryer gas manifold and the building gas regulator.

**1.7. FLEXIBLE GAS LINE LENGTHS**

The Flexible Gas Line used to connect the gas manifold to the building gas supply line must be rated for the BTU/Hr (MJ/Hr) designated for the Fryer. Flexible gas lines and their ratings stocked by Ultrafryer Systems are listed below:

<b>FLEXIBLE GAS LINES STOCKED BY ULTRAFRYER SYSTEMS</b>			
<b>NUMBER</b>	<b>DESCRIPTION</b>	<b>RATING</b>	
		<b>BTU/HR</b>	<b>(MJ/HR)</b>
24322	¾" (19mm) Diameter Flexible Gas Line (w/quick connect couplings) 48" (1219mm) long. Connect-It SSGC75-48-UCQ	225,000	(238)
24323	1" (25mm) Diameter Flexible Gas Line (w/quick connect couplings) 48" (1219mm) long. Connect-It SSGC100-48-UCQ	435,000	(459)
24456	1 ¼" (32mm) Diameter Flexible Gas Line (w/quick connect couplings) 48" (1219mm) long. Connect-It SSGC125-48-UCQ	875,000	(924)

**2. PRE-INSTALLATION**

**2.1. GENERAL**

Safe and satisfactory operation of a Model F-IRD-14 premix gas fryer depends on its proper installation. Installation must conform to local codes or, in the absence of local codes, with the current National Fuel Gas Code ANSI Z223.1/NFPA 54 or (latest edition). In Canada, gas installation shall be in accordance with the current CSA B 149.1 and .2 installation codes and/or local codes. Each Model F-IRD-14 premix gas fryer should be installed as follows:

1. Placed beneath a properly designed exhaust hood
2. Installed by a licensed electrician and plumber.
3. Connected to the type gas for which the unit was fabricated as shown on the rating plate.
4. Connected to the proper size pressure regulator installed in the gas supply line and adjusted to the proper manifold pressure.
5. Connected to the main gas supply line with the proper size supply line.
6. Restrained by use of a restraining device to avoid splashing of hot liquid and to assure tension cannot be placed on the flexible gas or electrical lines or fittings. CLEARANCES: The appliance must be kept free and clear of all combustibles. The minimum clearance from combustible and non-combustible construction is 6" (152 mm) from the sides, and 6" (152 mm) from rear. The fryer may be installed on combustible floors.

**NOTE:**

**Adequate clearance must be provided for servicing and proper operation.**

## 2.2. STANDARDS

Installation must be planned in accordance with all applicable state and local codes, considering the following standards:

1. The fryer and its individual shut-off valve must be disconnected from the gas supply piping system during any pressure testing of that system at pressures in excess of 1/2 psig (3.45kPa). In Canada, gas installation shall be in accordance with the current CSA B 149.1 and .2 installation codes and/or local codes.
2. The fryer must be isolated from the gas supply piping system by closing its individual manual shut-off valve during any pressure testing of the gas supply piping system at pressures equal to or less than 1/2 psig (3.45kPa).
3. When installed the fryer must be electrically grounded in accordance with local codes, or in the absence of local codes, in accordance with the current National Electrical code ANSI/NFPA 70 (latest edition). In Canada electrical installation must be in accordance with the current CSA C22.1 Canadian Electrical Code and/or local codes.
4. Other applicable nationally recognized installation standards such as:
  - a. National Fuel Gas Code ANSI Z223.1/NFPA 54 (latest edition)  
American Gas Association
  - b. NFPA Standards #54, #94 and #221 (latest edition)  
National Fire Protection Association
  - c. ANSI Z21.69/CSA-6.16 AND ANSI Z21.41/CSA 6.9
5. Exhaust vent hood, when installed must conform to the current NFPA 54-1 and Canadian Standards (latest edition)

**NOTE:**

**Local building codes will usually not permit a fryer with its open tank of hot oil to be installed immediately next to an open flame of any type, whether a broiler or an open burner or range. Check local codes before beginning installation.**

## 2.3. AIR SUPPLY AND VENTILATION

The area around the appliance must be kept clear of any combustible or flammable products and avoid any obstruction to the flow of ventilation air as well as for ease of maintenance and service. NOTHING is to be stored in the interior of the fryer's cabinet.

1. A means must be provided for any commercial, heavy duty-cooking appliance to exhaust combustion wastes outside of the building. It is essential that a fryer be set under a powered exhaust vent hood or that an exhaust fan be provided in the wall above the unit, as exhaust temperatures are in the vicinity of 400°F (204°C).

**NOTE:**

**Strong exhaust fans in a hood or in the overall air conditioning system can produce slight air drafts in the room, which can interfere with burner performance and be hard to diagnose. Air movement should be checked during installation and if burner problems persist, make-up air openings or baffles may have to be provided in the room.**

2. Exhaust temperature, in addition to the open tank of hot oil, make the storage of anything on shelving over or behind the fryer unsafe.
3. Filters and drip troughs should be part of any industrial hood, but consult local codes before constructing and installing any hood.
4. Provisions must be made for an adequate supply of fresh air and adequate clearance must be maintained for air openings into the combustion chamber.

### 3. RECEIVING AND INSTALLING

#### 3.1. UNPACKING

Check that the container is upright. Use an outward prying motion – DO NOT USE A HAMMER - to remove the carton. Check the fryer for visible damage; if such damage has occurred do not refuse shipment, but contact the carrier and file the appropriate freight claims.

#### 3.2. INSTALLING

Roll the assembled fryer into the building, to its operating location.



**IMPROPER INSTALLATION, ADJUSTMENT, ALTERATION, SERVICE, OR MAINTENANCE CAN CAUSE PROPERTY DAMAGE, INJURY, OR DEATH. READ THE INSTALLATION, OPERATING AND MAINTENANCE INSTRUCTIONS THOROUGHLY BEFORE INSTALLING OR SERVICING THIS EQUIPMENT.**

#### 3.3. LEVELING

1. When the fryer is placed in its operating location, check to be sure it is level. If not, loosen the casters and insert the appropriate number of shim plates between leg and caster plates then retighten the caster bolts.
2. If the floor is smooth and level, adjust to the high corner and measure with a spirit level. If the floor is uneven or has a decided slope, level the unit with metal shims.

**NOTE:**

**A Caster may not return exactly to the same position after being moved, which may require re-leveling after each move.**

3. Connect the gas manifold to the building gas supply line by means of a CSA Group APPROVED flexible gas line as shown in the figure below.

**NOTE:**

**CONNECT-IT Inc. ¾" (19mm), 1" (25mm) and 1 ¼" (32mm) flexible gas hose 4 feet long (1219mm) with a quick disconnect coupling on one end is available from Ultrafryer Systems under PN 24322 (¾" (19mm) hose), PN 24323 (1" (25mm) hose) and PN 24456 (1 ¼" (32mm) hose). These hoses are equipped with a fusible link, which melts at 316 °F (183 °C) that will SHUT OFF the gas supply when it melts. Reference Installation Instructions sheet provided with hose for additional information. A 44" (1119mm) long restraining device is also available under PN 24324. Install as Shown below between the wall and fryer using existing mounted hardware or add hardware to the wall and fryer making a secure connection at each end.**

CAUTION:



**THE BUILDING GAS SUPPLY LINE MUST BE SIZED TO PROVIDE THE VOLUME OF GAS REQUIRED FOR PROPER OPERATION AS EXPLAINED ON THE PREVIOUS PAGE.**

### Typical Gas Connection

- |                                |                              |
|--------------------------------|------------------------------|
| 1. BUILDING GAS SERVICE LINE   | 6. APPLIANCE MANIFOLD/NIPPLE |
| 2. MAIN GAS CUT-OFF VALVE      | 7. EYELET FASTENERS          |
| 3. CONNECT-IT QUICK-DISCONNECT | 8. SPRING HOOK               |
| 4. FLEX-CON CONNECTOR          | 9. RESTRAINING CHAIN         |
| 5. ELBOW                       |                              |

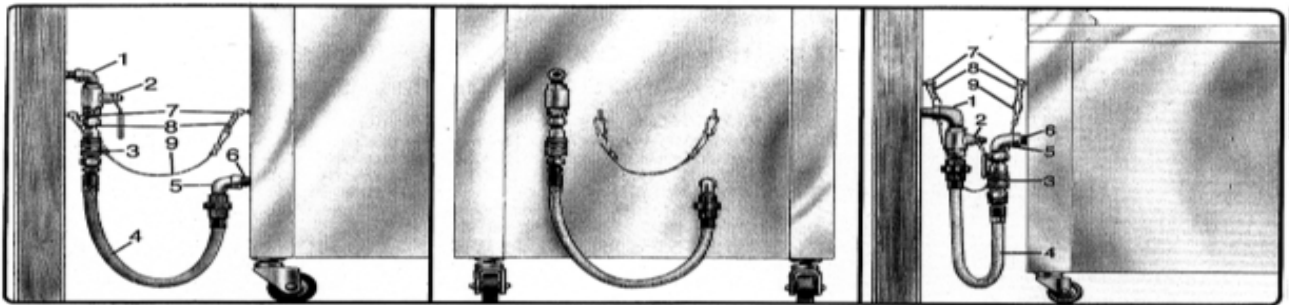

WARNING:



**THE RESTRAINT DEVICE (ITEM 9) MUST BE INSTALLED TO ASSURE TENSION CANNOT BE PLACED ON THE FLEXIBLE GAS LINE OR FITTING..**

### 3.4. GAS CONNECTION

The gas supply (service) line must be the same size or greater than the inlet line of the appliance. THE GAS SUPPLY LINES MUST BE SIZED TO ACCOMMODATE ALL THE GAS FIRED EQUIPMENT THAT MAY BE CONNECTED TO THAT SUPPLY.

Refer to the inlet gas line sizing table and inlet gas requirements.

#### NOTE:

**Sealant used on all pipe joints must be resistive to natural and propane gas**

1. Manual shut off valve: This supplier-installed valve must be installed in the gas service line ahead of the appliance and in a position where it can be reached quickly in the event of an emergency.
2. Pressure regulator: All commercial cooking equipment must have a pressure regulator on the incoming service line for safe and efficient operation, because service pressure may fluctuate with local demand. External regulators are not required on this fryer, as that function is performed by a combination gas control valve, however if the incoming pressure is in excess of 1/2 psi, a step-down regulator will be required.
3. Natural gas: Natural gas fryers require 7" (178mm) water column (W.C.) "inlet" pressure to the fryer's combination gas control valve for proper operation, when all gas units are operating simultaneously. Propane gas fryers require 14" (356mm) water column (W.C.) "inlet" pressure to the fryer's combination gas control valve for proper operation, when all gas units are operating simultaneously. This "inlet" pressure **MUST** be checked with a manometer **PRIOR** to placing the fryer in operation.



**IF THE "INLET" GAS PRESSURE AT THE FRYERS COMBINATION GAS CONTROL VALVE "EXCEEDS" 1/2 lb/in<sup>2</sup> (.035 kg/cm<sup>2</sup>) OR APPROXIMATELY 11" (280mm) W.C., AN EXTERNAL REGULATOR MAY BE NEEDED TO PREVENT DAMAGE TO THE COMBINATION GAS VALVE, AND VOIDING OF WARRANTY.**

4. Combination gas control valve: The correct combination gas control valve and orifice is installed at the factory for **NATURAL** and **PROPANE** units based on each Purchase Order. This valve should be **CHECKED/ADJUSTED** by qualified service personnel using proper test equipment for the following "**OUTLET**" gas pressure **PRIOR** to start-up of a fryer.
  - a. NATURAL GAS FRYERS 7" (178mm) W.C.
  - b. PROPANE FRYERS 14" (355.6mm) W.C.
5. Rigid connections: Visually check any installer-supplied intake pipe(s) with compressed air to clear dirt particles, threading chips or any other foreign matter before connecting to the service line as these particles may clog the orifice when gas pressure is applied. All connections must be tested with a soapy solution before lighting the fryer. **DO NOT USE AN OPEN FLAME TO CHECK FOR LEAKS!** Putting an open flame beside a new connection is not only dangerous, but will often miss small leaks that a soapy solution would find.

**FLEXIBLE COUPLINGS AND CONNECTORS:** The installation is to be made with a connector that:

1. Complies with the **Standard for Connectors for Movable Gas Appliances, ANSI Z21.69/CSA 6.16**, and a quick-disconnect device that complies with the **Standard for Quick-Disconnect Devices for Use With Gas Fuel, ANSI Z21.41/CSA 6.9**
2. Adequate means must be provided to limit the movement of the appliance without depending on the connector and the quick disconnect device or its associated piping to limit the appliance movement.

3. The location(s) where the restraining means may be attached to the appliance shall be specified. Mounting holes for restraining cable is located on the rear legs of the fryer carriage.

### **DOMESTIC CONNECTORS ARE NOT SUITABLE!!!**

**FRYER SERVICE:** The fryer is equipped with swivel casters. To service the fryer:

- a) Remove / unplug power supply from fryer
- b) Turn "OFF" gas supply at the supply source.
- c) Disconnect the flexible gas line quick-disconnect
- d) Disconnect restraint means and roll fryer out for rear service access.
- e) When the fryer is re-positioned, be sure to reconnect the restraint and level the fryer.

### **3.5. ELECTRICAL CONNECTION**

The MAXIMUM current draw per vat at Initial Start-up or during a Warm-up Cycle will be 3 Amperes at 120 Volts. Refer to the wiring diagram attached to the inside of the Service Access door for internal electrical connections.

**WARNING:**



#### **ELECTRICAL GROUNDING INSTRUCTIONS**

**THIS APPLIANCE IS EQUIPPED WITH A THREE-PRONG (GROUNDING) PLUG FOR YOUR PROTECTION AGAINST SHOCK HAZARD AND SHOULD BE PLUGGED DIRECTLY INTO A PROPERLY GROUNDED THREE-PRONG RECEPTACLE. DO NOT CUT, REMOVE OR OTHERWISE BYPASS THE GROUNDING PRONG ON THIS PLUG!**

## **4. ULTRASTAT 402 COOKING COMPUTER**

### **4.1. THE ULTRASTAT 402 COOKING COMPUTER**

The Ultrastat 402 Cooking Computer is a high performance, microprocessor-based electronic controller designed for use in commercial appliance temperature and timing control applications. Utilizing a Touch Screen Display front panel, the Ultrastat 402 cooking computer has been customized for ultrafryer systems applications by the addition of up to 10 stage cooking profiles for each of the 10 product keys; features can be programmed to cook products under "Flex" or "Straight" timing modes. Operation of the Ultrastat 402 cooking computer is covered in its instruction manual PN 30A286 provided with the Fryer.

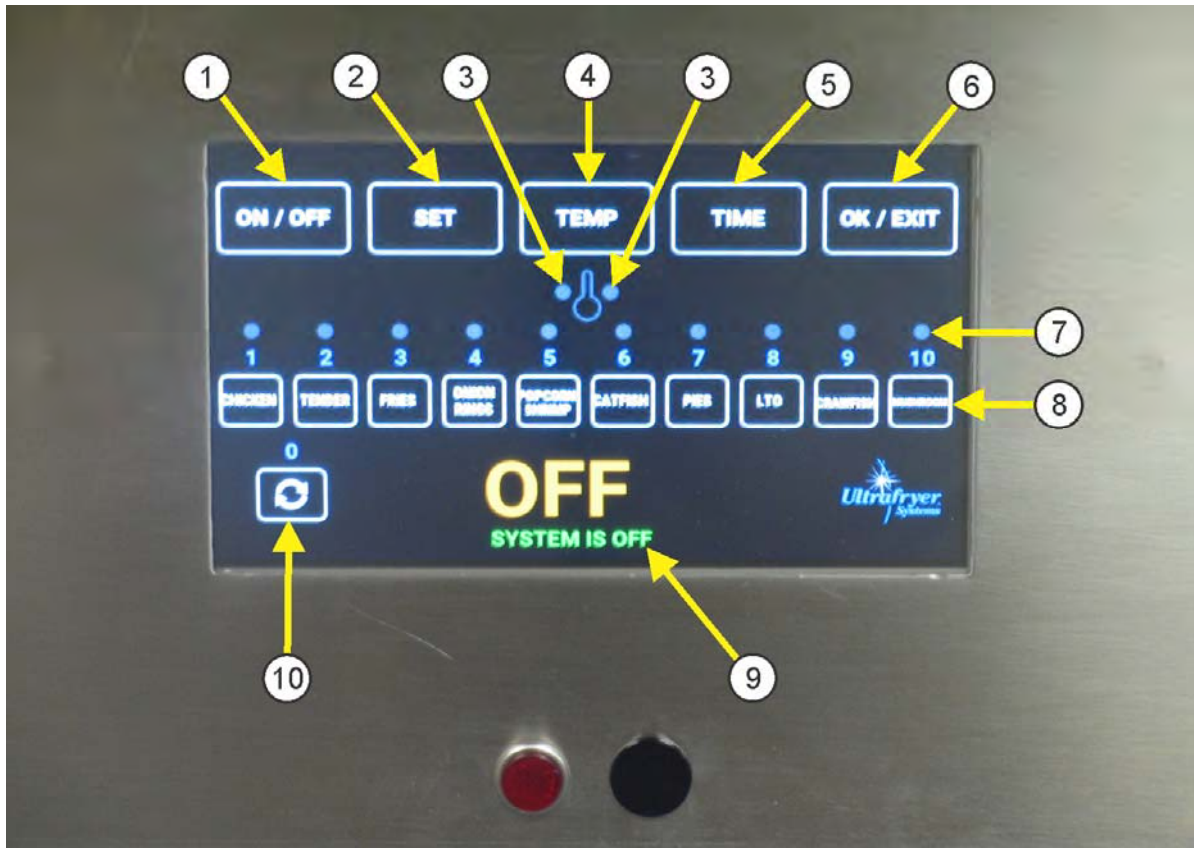

## 4.2. COMPUTER PANEL KEY DESCRIPTIONS

### 1. ON/OFF KEY

- Turn the Computer ON and OFF.
- If equipped, the fryer toggle ON/OFF switch is in the **ON** position and the Drain Lever in the closed **UP** position.

### 2. SET KEY

- In "operating" mode, allows access to the programming mode
- In "programming" mode, allows access to the operating mode.

### 3. HEAT DEMAND LEDS

When lit (bright) indicate the computer is calling for heat.

### 4. TEMPERATURE KEY

- When depressed one time, displays actual shortening temperature for 3 seconds.
- When depressed two times, within 3 seconds, displays current setpoint temperature for 3 seconds.
- When depressed three times, within 3 seconds, will return to previous display.

### 5. TIME KEY

Used to display remaining cook time of a product, activate/abort the recipe display of a product and start the Filter Timer.

**6. ON/EXIT KEY**

- a. In "operating" mode used to manually exit the shortening melt cycle, exit the Filter Timer, and activate/exit the setback mode.
- b. In "programming" mode serves as an ACCEPT key.

**7. PRODUCT LED**

- a. When **BLINKING** fast, in "cooking" mode indicates cooking of that product is in process.
- b. When **BLINKING** slow, indicates cooking of that product is complete.

**NOTE:** When several products are in the "cooking" mode and the **TIME KEY** is pushed, the Product LED of the first to finish will **BLINK** fast and the order LED's will **BLINK** slow. When the cook cycle of the "first" product key is complete, its LED will blink **FAST** and the other product key LEDs will turn **OFF**.

- c. When lit **BRIGHT** in the "programming" mode, indicates the product is being programmed.

**8. PRODUCT COOK AND PROGRAMMING KEY**

- a. In "operating" mode, used to start and stop a product cook cycle.
- b. In "programming" mode, used to enter numerical values 1 to 9 and to select **RECIPE** or **FEATURES** to be programmed.

**9. DISPLAY**

Displays modes, functions and operation of the computer.

**10. TOGGLE /PROGRAMMING KEY**

- a. In "programming" mode, it is used to enter the numerical value of "0" and "toggle" (switch) between **FLEX/STRAIGHT** time modes, **HIGH/LOW** melt release temperature and **CELSIUS/FARENHEIT** temperature unit.
- b. In "operating" mode, it can be pushed to display the current **HIT COUNT** and **TIME PROMPT**

4.3. ULTRASTAT 402 PROGRAMMING GUIDE



## ULTRASTAT 402 PROGRAMMING GUIDE

- 1



If equipped, turn **Toggle ON/OFF** switch to **ON** position and **AMBER** power indicator lamp will illuminate
- 2



Press **ON/OFF** key. **Melt E, G, or P** will appear in the display
- 3



Press the **SET** key. **PROGRAM** will appear in the display.
- 4



Enter the **COOK PASSWORD "3660"** to program product keys. **RECIPE** will appear in the display. All product key LED's will light.
- 5



Press the **PRODUCT KEY** to be programmed. ie. 1-8. Product Key LED will light, Indicating ready to be programmed. **NUMBER of STEPS** appears in the display.
- 6



Enter number of cooking steps to be programmed then press **OK/EXIT** key. The time for steps 1 to begin will appear in the display indicating **TOTAL COOK TIME**
- 7



Enter the time the **STEP** is to begin. Then press **OK/EXIT** key. **STRAIGHT/FLEX** will appear in the display.
- 8



Press the **0** KEY to toggle between **STRAIGHT** or **FLEX** timing mode and press **OK/EXIT**. **STEP TEMP** will appear in display indicating Temp. In "F" for product is to be entered.
- 9



Enter **TEMP** for this step. Then press **OK/EXIT** key. Repeat instructions 6-9 for each step. When finished with each step **NUMBER OF ALARMS** will appear in the display.
- 10



Enter number of stir alarms desired. Then press **OK/EXIT** **ALARM TIME** will be displayed indicating the time for the alarm signal to be entered.
- 11



Enter the Time the alarm is to begin. Then press the **OK/EXIT** key. **HITS 00** will be displayed. Enter **00** to finish programming for this product. Then press the **OK/EXIT** key.
- 12



Repeat above steps for each product key to be programmed. Once all product keys are programmed press the **SET** key **TWICE** to exit **PROGRAMMING MODE**

#### 4.4. ULTRASTAT 402 START-UP AND COOKING COMPUTER OPERATION

##### NOTE:

- 1) The computer will keep the fryer in the melt cycle until the exit melt button is manually depressed.
- 2) The computer cannot be taken out of the shortening melt mode until the shortening temperature reaches the melt limit temperature. The melt limit temperature is factory set for a high exit temperature (135°F/57°C) or a low exit temperature (100°F/38°C).

The following are abbreviated operating procedures for a fryer equipped with an Ultrastat 402 Cooking Computer. The attached Ultrastat 402 Ultrafryer Computer Operating Instructions, Manual PN 30A286, contains DETAILED Operating, Filtering, Boil-Out and Programming Instructions.

##### 4.4.1 START-UP and COOKING

STEP	ACTION	RESPONSE
1	ENSURE the drain valve lever on the fryer is in the CLOSED position, shortening is at the proper level, then turn the computer ON by depressing the computer ON/OFF button.	A. The fryer heat exchanger will power up and begin to heat the shortening.

4.4.2 ULTRASTAT 402 START-UP - Safely start-up a gas fryer equipped with a Ultrastat 402 Cooking computer as follows:

CAUTION:



PRIOR TO PROCEEDING TO NEXT STEP, VISUALLY CHECK THAT THE HEAT EXCHANGER IS COVERED WITH AT LEAST 2" (51mm) OF SHORTENING.

2	Turn the Computer ON by depressing the computer ON/OFF button.	<p>A. The MELT lamp will LIGHT to indicate the computer is in the SHORTENING MELT MODE.</p> <p>B. The HEAT lamp on the computer and the RED heat mechanism indicator lamp on the fryer will cycle ON and OFF indicating the heat mechanism is periodically being turned ON and OFF to gently heat the shortening.</p>
3	Once the Melt Limit Temperature is reached depress the EXIT MELT BUTTON on the computer to cancel the SHORTENING MELT MODE.	<p>A. "HEATING" will appear in the computer display indicating shortening temperature is more than 10°F (5°C) below the set-point temperature.</p> <p>B. The HEAT lamp on the computer and the RED heat mechanism indicator lamp will remain ON until the set-point temperature is reached.</p>
4	When "READY" appears in the Computer display indicating the SET-POINT TEMPERATURE of the shortening has been reached, a COOK cycle can be initiated.	A. Stir the shortening several times to ensure that all the shortening has reached the set point temperature.

#### 4.4.3 ULTRASTAT 402 COOKING COMPUTER PROGRAMMING

Program the Ultrastat 402 Cooking Computer according to the, Computer Operating Instructions Manual, (PN 30A286) provided with the Fryer.

#### NOTE:

Programming of an Ultrastat 402 cooking computer should only be performed by a store manager or area supervisor.

#### 4.5. GENERAL COOKING

Most products should be cooked with a shortening temperature about 350°F (177°C); however, each product should be cooked at the LOWEST temperature that produces a high quality product while obtaining maximum usage of the shortening.

#### WARNING:



- I. DO USE A HIGH QUALITY SHORTENING TO ACHIEVE A CONSISTENT QUALITY PRODUCT AND LONG TERM SAVINGS
- II. DO NOT SALT PRODUCTS OVER THE FRYER AS SALT QUICKLY DETERIORATES THE SHORTENING AND FLAVORS OTHER PRODUCTS COOKED IN THE SAME SHORTENING
- III. DO FILTER SHORTENING AFTER THE LUNCH AND DINNER RUSH AND MORE OFTEN IN A HIGH SALE VOLUME STORE; AND BOIL-OUT THE FRYER EVERY 7 DAYS

#### NOTE:

Startup steps 1, 2, 3 and 4 will have to be repeated each time any of the following occurs:

Drain valve is open, fryer ON/OFF switch is turned OFF to filter shortening or boil-out a fryer. Fryer ON/OFF switch is turned OFF at closing or any other reason.

#### POWER FAILURE

This fryer cannot be operated during power failures. **DO NOT** attempt to bypass safety and manually operate fryer.

#### CAUTION:



THE FRYER HAS A RESTRAINT ATTACHED TO THE WALL TO LIMIT MOVEMENT AND TIPPING IN ORDER TO AVOID SPLASHING OF HOT LIQUID.

MOVING THE FRYER WITH HOT COOKING OIL IN THE VESSEL MAY CAUSE SPLASHING OF THE HOT LIQUID CAUSING SEVERE BURNS.

IF MOVING THE FRYER IS REQUIRED FOR CLEANING OR SERVICING. TAKE THE REQUIRED STEPS OF REMOVING THE RESTRAINT, POWER AND GAS CONNECTIONS BEFORE MOVING THE FRYER AND MAKE SURE THE COOKING OIL IN THE VESSEL IS COLD OR HAS BEEN REMOVED FROM THE VESSEL TO LIMIT ACCIDENTAL BURNS OR DAMAGE TO THE FRYER.

When the Computer is taken out of the SHORTENING MELT MODE each morning, shortening in the fryer vat will be heated to its SETPOINT temperature, "HEATING" will appear in the display to indicate the shortening temperature is MORE than 20°F (-6.6°C) BELOW the set point temperature. When shortening temperature rises to the SETPOINT temperature, "READY" will appear in the display indicating a COOK CYCLE can be started.

#### 4.6. STARTING A COOK CYCLE

To start a cook cycle simply press the product key for the product you wish to cook. Cook time will be displayed "3:00" (example) and this time will immediately start to count down in minutes and seconds. It will count down to " :00" followed by a beeping signal. To turn this signal OFF and reset the Computer, press the same product key used to start the COOK CYCLE.

#### 4.7. CANCELLING A COOK CYCLE

If a cook cycle was inadvertently started it may be cancelled two (2) ways:

- 1) Press and hold the same product key used to start the cook cycle for 4 SECONDS. This prevents an accidental start of a cook cycle while a product is being cooked.
- 2) A cook cycle can be CANCELLED at any time by turning the fryer ON/OFF Switch to the OFF position.

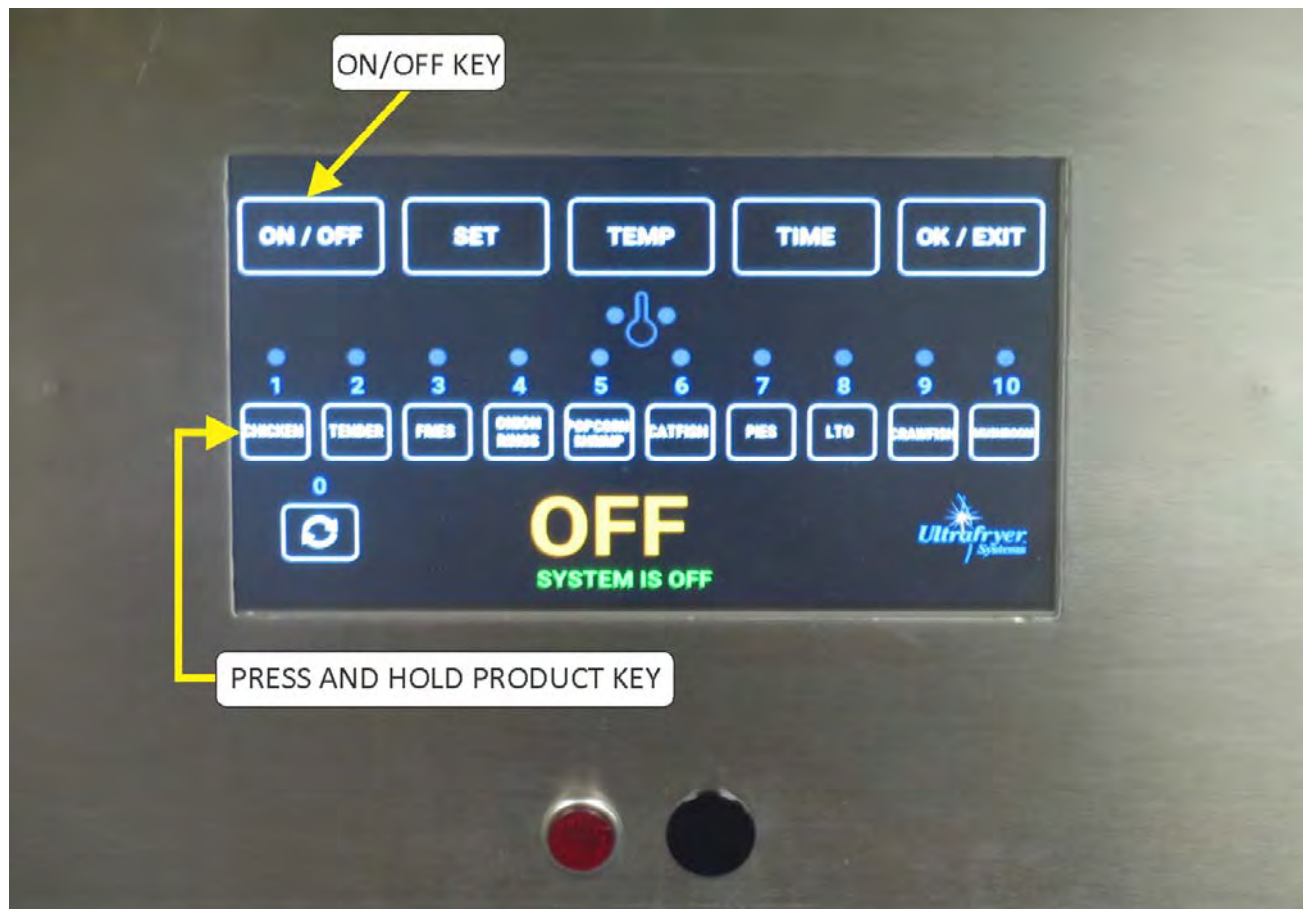

## 5. CLEANING

### 5.1. GENERAL CLEANING

Any item of equipment operates and lasts longer when kept clean and properly maintained, and the Ultrafryer is no exception.

In order for this fryer to provide years of trouble-free service, it must be CLEANED and MAINTAINED according to the instructions listed below.

#### DAILY

- 1) Clean the fryer surfaces periodically during operating hours with a solution of sanitizer and hot water, and at closing with stainless steel cleaner. If necessary, use a dampened type 7447 RED or 7440 BROWN (heavy duty) Scotch brite pad to remove encrusted material. DO NOT use steel wool, abrasive cloths, cleaners, powders, metal knife, spatula or any metal object to scrape stainless steel! Scratches on stainless steel are almost impossible to remove.
- 2) Filter the shortening in each fryer once a day or according to Company Policy.

CAUTION:



**DO NOT ALLOW ANY CLEANING SOLUTION OR WATER TO SPLASH INTO A VESSEL OF HOT COOKING OIL, AS IT WILL CONTAMINATE THE OIL AND MAY CAUSE THE OIL TO SPLATTER CAUSING SEVERE BURNS.**

#### WEEKLY

- 1) BOIL-OUT the fryer vat using Boil Out Compound according to procedures in the cleaning manual provided by the chemical provider.
- 2) Perform steps 1 and 2 listed above under the Daily Cleaning.

## 6. PREVENTIVE MAINTENANCE AND TROUBLESHOOTING

### 6.1. PREVENTIVE MAINTENANCE

Minimal maintenance is required on the fryer because of its design and the materials used in the manufacturing process. However, some preventive maintenance and inspection must be performed periodically to prevent break downs which could curtail food sales. Any preventive maintenance or inspection should be accomplished with **CAUTION** while the fryer is in operation since **HOT** liquid shortening could cause severe burns. If service or repair is required, all gas and electric power **MUST BE TURNED OFF PRIOR** to performing any service or repair. The following chart describes the minimum items to be inspected and the inspection interval:

**Table 1. Daily Preventive Maintenance Inspection Schedule.**

Item	Inspection Description
Grease Filters	Clean grease filters in the exhaust hood evening and allow them to dry overnight

**Table 2. Weekly Preventive Maintenance Inspection Schedule.**

Item	Inspection Description
Drain Valve Handle	Determine if the drain valve handle is securely attached to the drain valve and that the valve can be easily opened and closed.
Temperature Sensing and Dry Fire Probes	During boil-out of the fryer, inspect the temperature, high limit sensing and Dry Fire probes for any visual damage.

**6.2. TROUBLESHOOTING**

**6.2.1 GENERAL:** The problems and possible solutions listed in the troubleshooting chart below are typical problems that are frequently encountered. **ONLY** qualified repairmen are to use the troubleshooting chart to repair this fryer. In the event a main burner malfunction occurs, perform the following checks **PRIOR** to contacting a repairman:

1. Check that the fryer electrical plug is connected to an electrical receptacle.
2. Ensure the applicable Circuit Breaker is in the **ON** position and that the fryer ON/OFF switch is in the **ON** position.
3. Ensure the applicable fryer control has been placed in the **EXIT MELT** mode.
4. Ensure the gas supply line quick-disconnect coupling is **SEATED** on the gas manifold fitting.
5. Determine that the blower is operating.

**TROUBLESHOOTING CHART:** Should a problem occur that cannot be corrected after performing the above CHECKS, contact an **AUTHORIZED** repairman and/or Ultrafryer Systems Customer Service 1-800-525-8130 and provide the information acquired while performing these checks.

<u>ITEM</u>	<u>PROBLEMS</u>	<u>POSSIBLE SOLUTIONS</u>
1	Ignition Lockout	1.) Harness connection to gas valve 2.) Gas valve or gas pressure 3.) All harness connections 4.) Electrode 5.) Interconnecting wiring malfunction 6.) Ignition module malfunction 8.) Grounding Status
2	No spark, No blower	1.) Harness connections 2.) Probe lead wires 3.) Open probe 4.) Controller

3	“Puffing” during normal start up	1.) Incorrect gas pressure 2.) Cracked electrode 3.) Electrode gap exceeded
4	Burner lights but will not maintain flame	1.) Igniter / flame sense misalignment 2.) Insufficient gas pressure
5	Excessive Heat	1.) Incorrect temperature offset selected 2.) Set Temperature exceeding 400 deg F 3.) Temperature probe malfunction 4.) Cooking control malfunction 5.) Interface board malfunction 6.) Gas pressure incorrect
6	Low heat	1.) Incorrect temperature offset selected 2.) Cooking control malfunction 3.) Temperature probe malfunction 4.) High limit tripped 5.) Interface board malfunction 6.) Gas pressure incorrect
7	Intermittent problems	1.) High ambient temperatures 2.) Wiring connections loose
8	No power to cooking control, fryer does not heat	1.) Is displayed “OFF” when Powered 2.) Main circuit breaker off 3.) Transformer inoperative 4.) Interconnecting wiring malfunction
9	High limit thermostat shutting down system	1.) Shortening level below minimum fill line 2.) Probe malfunction 3.) Controller malfunction
10	Excessive time to melt shortening	1.) Melt cycle timing incorrect 2.) Insufficient gas pressure 3.) Probe malfunction 4.) Control malfunction
11	Dry fire fry tank	1.) No shortening in vat 2.) Control malfunction 3.) Probe malfunction



**ENSURE REPAIRMEN ARE ADVISED THAT FRYER RESTRAINTS MUST BE DISCONNECTED/CONNECTED. IF A FRYER IS TO BE MOVED DURING MAINTENANCE OR REPAIR, AND THAT ELECTRICAL POWER AND GAS MUST BE TURNED OFF PRIOR TO PERFORMING ANY MAINTENANCE OR REPAIR.**

## 7. TECHNICAL ASSISTANCE, WARRANTY PARTS & REPLACEMENT PARTS ASSISTANCE

**7.1. TECHNICAL ASSISTANCE** - Contact an authorized service agent or the Customer Service Department Ultrafryer Systems at 1-800-525-8130 for Technical Assistance.

E-mail technical assistance at: techserv@ultrafryer.com

**7.2. WARRANTY PARTS** - Contact the Customer Service Department, Ultrafryer Systems at 1-800-525-8130 for parts assistance.

E-mail customer service at: techserv@ultrafryer.com

**7.3. REPLACEMENT PARTS** - Contact the Customer Service Department, Ultrafryer Systems at 1-800-525-8130 for Replacement Parts Assistance.

## 8. RECOMMENDED SPARE PARTS

### 8.1. RECOMMENDED SPARE PARTS

To minimize downtime on the premix gas fryer upon failure of a component part, at least one (1) of the following items should be kept as a spare part in a local area:

<b>PREMIX GAS FRYER RECOMMENDED SPARE PARTS LISTING</b>	
<u>DESCRIPTION</u>	<u>PN</u>
Computer, Cook U402	22A838
Blower Premix 5.0 Power Burner and Gas Valve	17A033
Gasket, Blower Motor / Manifold IDE	22A810
Burner Infrared 1x3x8 W/Mounting Plate	19D152
Rod, Ignitor Infrared Burner F/22A807	18610
Gasket, Mount Infrared Burner IDE 20in	22A811
Module, Ignitor Spark Dual Infrared	18A384
Transformer, Step Down 110V to 24V	18180
Transformer, FAST Wiring Harness	18A047
Relay, 24V DC 10 Amp SPDT Computer	23A023
Relay, 24V AC Flange Mounted	18A034
Control, 24VAC Universal Gas Blower (PWM)	23A462
Switch, Air Pressure	18A291
Switch, HI Limit 385 deg	19B782
Switch, Hi Limit 400 deg (alternate)	19B783
Probe, Temp Thermistor	18A006

Snap Light, Red Neon 125V 1/3 Watt	23043
Oil Proximity Kit, Control Dry Fire	23A510

9. PARTS IDENTIFICATION

9.1. IRD -14 - CONTROL PANEL

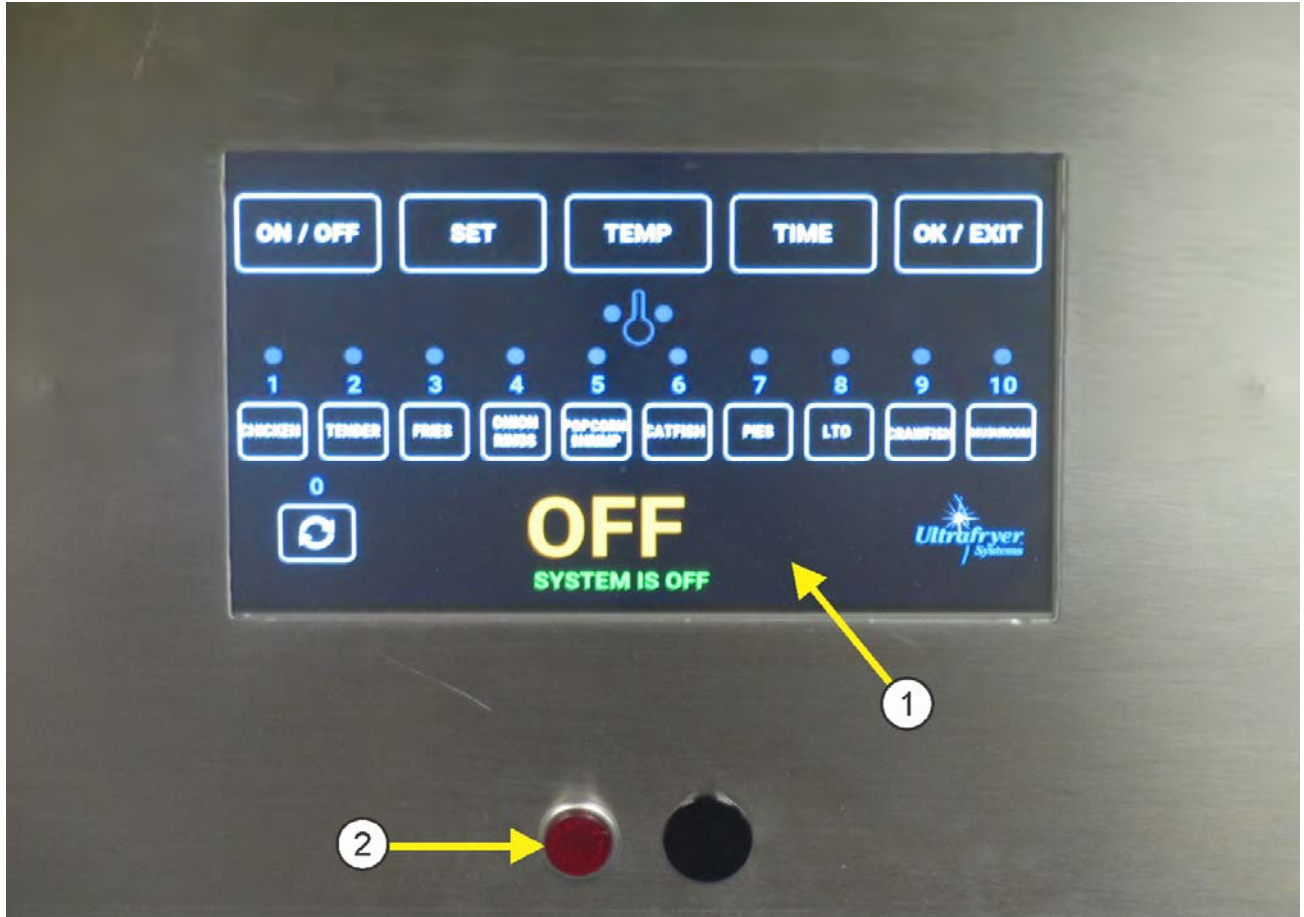

ITEM	DESCRIPTION
1	22A838 Computer, Cook U402
2	23043 Snap Light, Red Neon 125V 1/3 Watt

9.2. INSIDE ELECTRICAL BOX ASSEMBLY

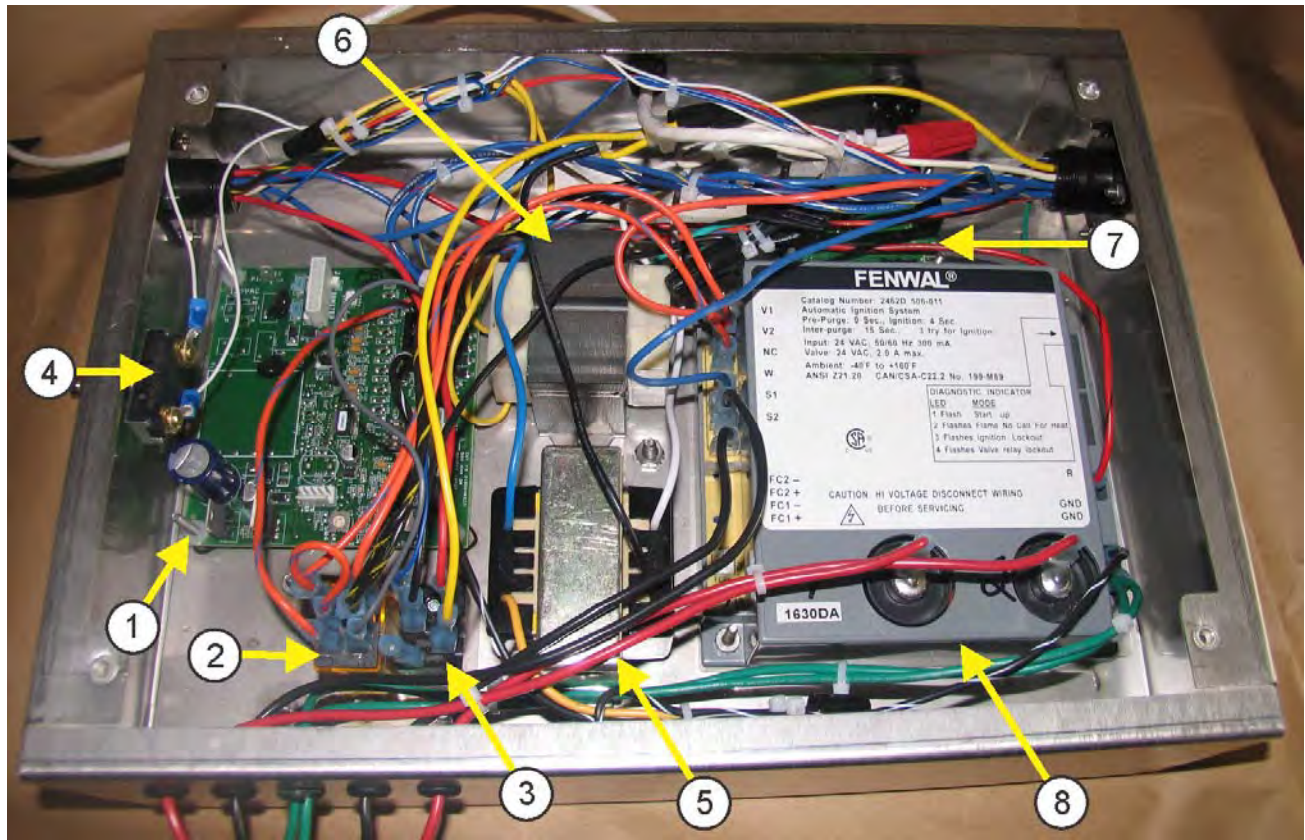

ITEM	DESCRIPTION
1	23A462 Control, 24VAC Universal Gas Blower (PWM)
2	18A034 Relay, 24VAC Flanged Mounted
3	23A023 Relay, 24VDC 10AMP SPDT Computer
4	18A387 Switch, Momentary Metal Plunger 15 AMP
5	18180 Transformer, Step Down 110V TO 24V
6	18A047 Transformer, Fast Wiring Harness
7	23A510 Oil Proximity Kit, Control Dry Fire
8	18A384 Module, Ignitor Spark Dual Infrared

## 9.3. CABINET FRONT VIEW

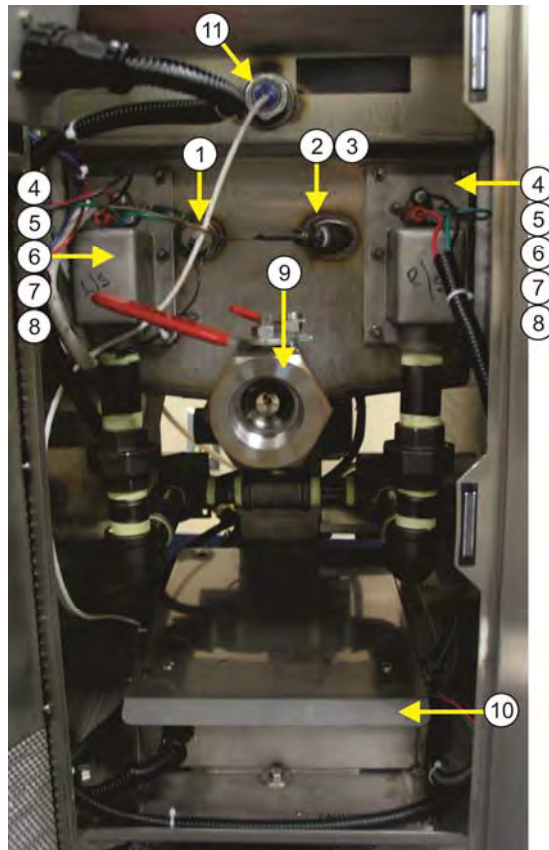

ITEM	DESCRIPTION
1	18A006 Probe, Temp Thermistor
2	19B782 Switch, Hi Limit 385 deg
2	19B783 Switch, Hi Limit 400 deg (alternate)
3	24A270 Fitting, Compression Male 3/8 NPT
4	19D078 Box Mount, Infrared Burner 14 IN
5	19D152 Burner Weld, IR 1x3x8
6	18610 Rod, Ignitor Infrared Burner
7	22A811 Gasket, Mount Burner Box
8	19D203 Baffle, Agitator 14 IN IRD Front
9	24A204 Valve, Ball 1½ IN Full W/Lock Mech.
10	12D208 Box Assy, Electrical 14" IRD
11	23A510 Oil Proximity Kit, Control Dry Fire

9.4. CABINET REAR VIEW

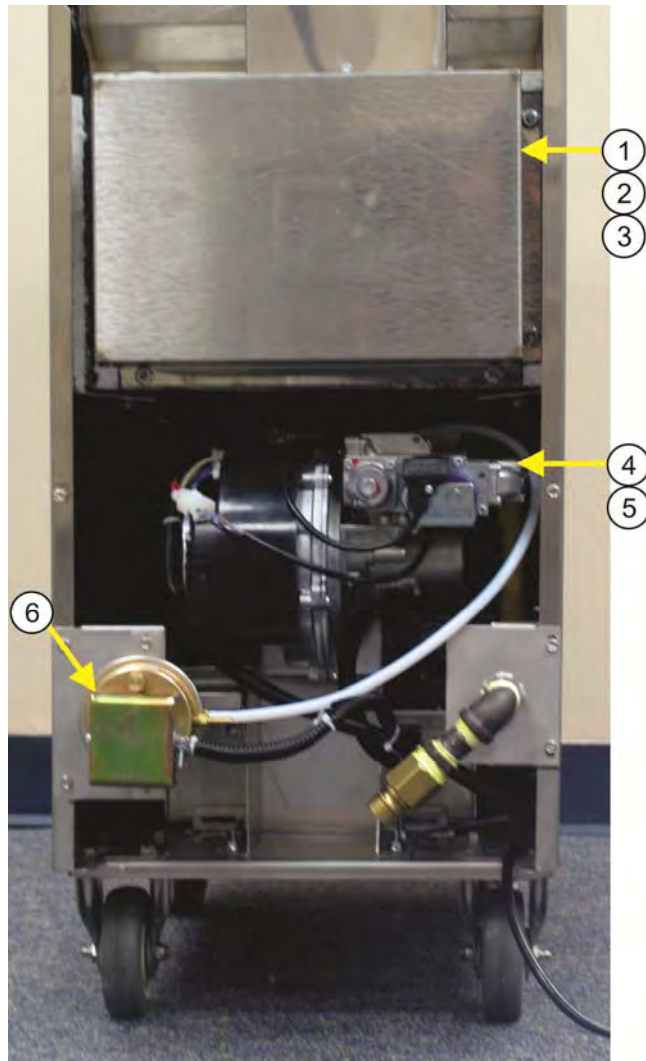

ITEM	DESCRIPTION
1	19D198 Box, Blower IRD 14 IN w/flue
2	22A852 Gasket, Blower Box IRD 14 IN
3	19D195 Baffle, Agitator 14 IN IRD Rear
4	17A033 Blower, Premix 5.0 Power Burner/Gas Valve
5	22A810 Gasket, Blower Motor/Manifold
6	18A291 Switch, Air Pressure SMD 1204

9.5. CABINET SIDE VIEW

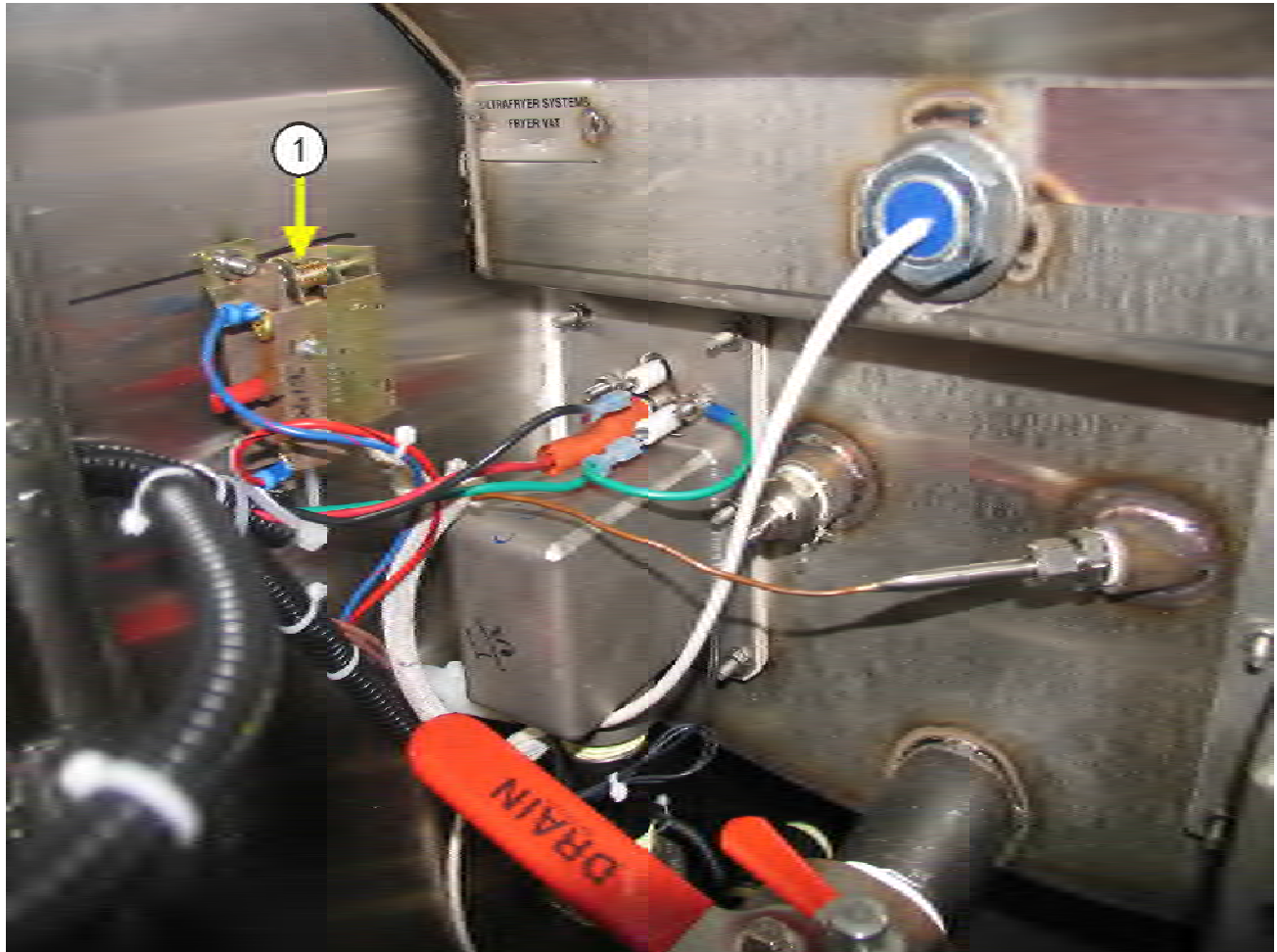

ITEM	DESCRIPTION
1	19B782 Switch, HI Limit 385 deg
1	19B783 Switch, HI Limit 400 deg (alternate)

## 10. SERVICE PROCEDURES AND ADJUSTMENTS

### 10.1. HARMONIC TONE

Harmonic tone (HUM) at first start, fryer will begin heating in low fire and a few seconds later go to high fire. There will be a harmonic tone that is normal to hear. As fryer continues to heat, harmonic tone will dissipate and become less noticeable.

### 10.2. GAS VALVE

WARNING:



**DISCONNECT THE ELECTRICAL POWER TO THE FRYER.**

WARNING:



**SHUT OFF THE GAS BEFORE SERVICING THE FRYER.**

WARNING:



**ALL GAS JOINTS DISTURBED DURING SERVICING MUST BE CHECKED FOR LEAKS.  
CHECK WITH A SOAP AND WATER SOLUTION (BUBBLES).  
DO NOT USE AN OPEN FLAME**

The gas valve is considered part of the Blower Premix 5.0 Power Burner and Gas Valve assembly. If the gas valve fails and needs to be replaced, you must order a complete blower / gas valve assembly (burner). The reason for this is every blower / gas valve assembly (burner) is set up at the factory to operate at the most efficient level possible. This set up procedure can not be duplicated in the field.

### 10.3 MODULATING GAS VALVE ADJUSTMENTS

WARNING:



**DISCONNECT THE ELECTRICAL POWER TO THE FRYER**

WARNING:



**SHUT OFF THE GAS BEFORE SERVICING THE FRYER.**

WARNING:



**ALL GAS JOINTS DISTURBED DURING SERVICING MUST BE CHECKED FOR LEAKS.  
CHECK WITH A SOAP AND WATER SOLUTION (BUBBLES).  
DO NOT USE AN OPEN FLAME**

The modulating gas valve is adjustable at the factory and requires no adjustment. If the modulating gas valve needs to be replaced, the new gas valve from the factory will be adjusted properly and will only need to have the gas pressure verified coming into the gas valve.

**10.4. TEMPERATURE PROBE SETTING**

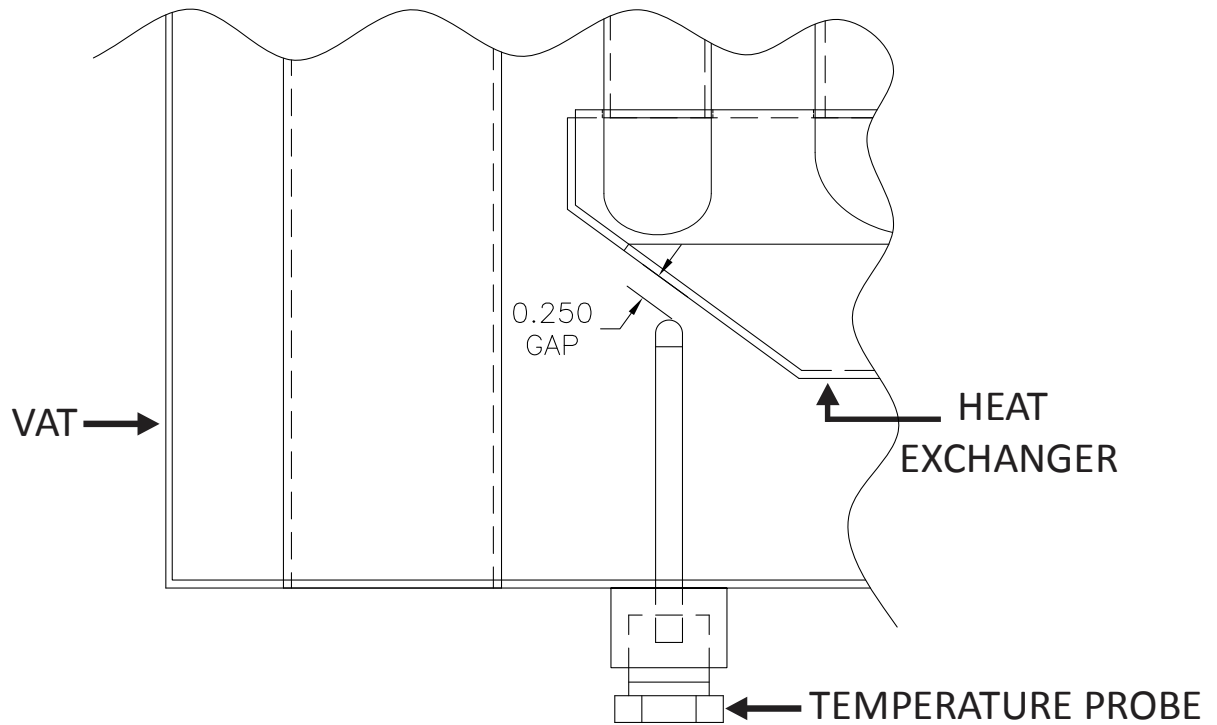

**10.5. HI LIMIT PROBE SETTING**

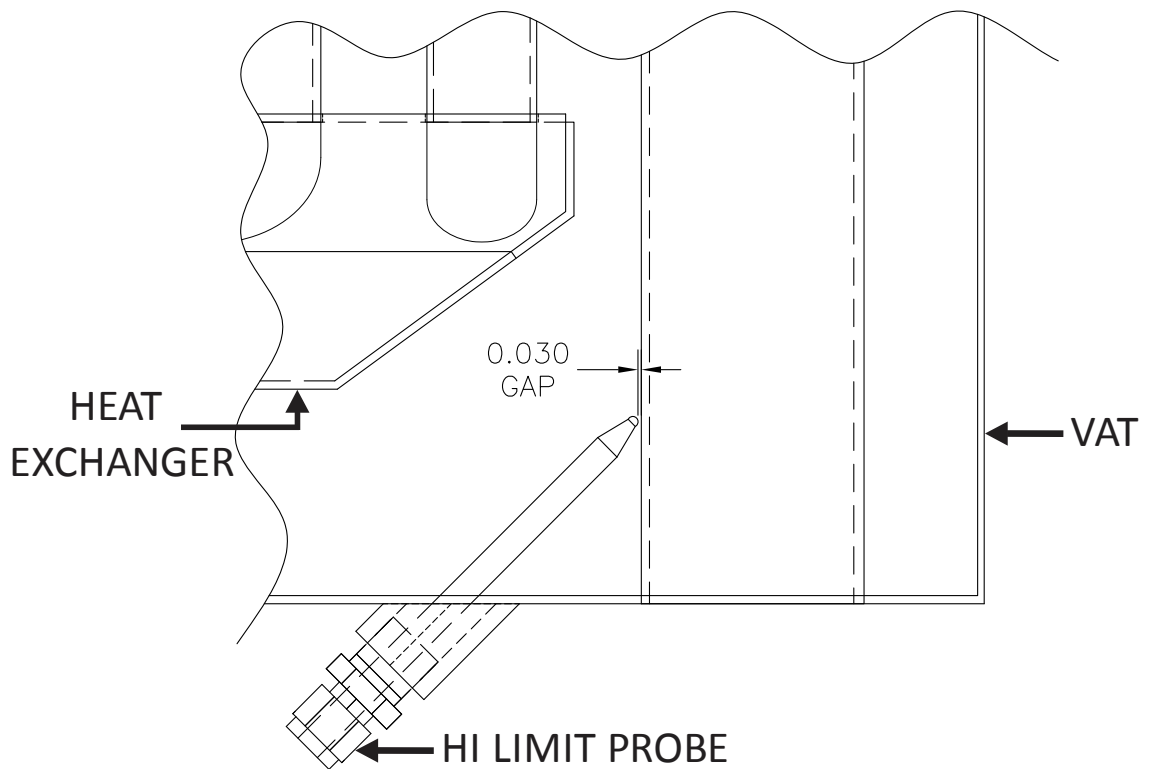



### 10.8. CONTROL, 24 VAC UNIVERSAL GAS BLOWER (PWM) SETTINGS

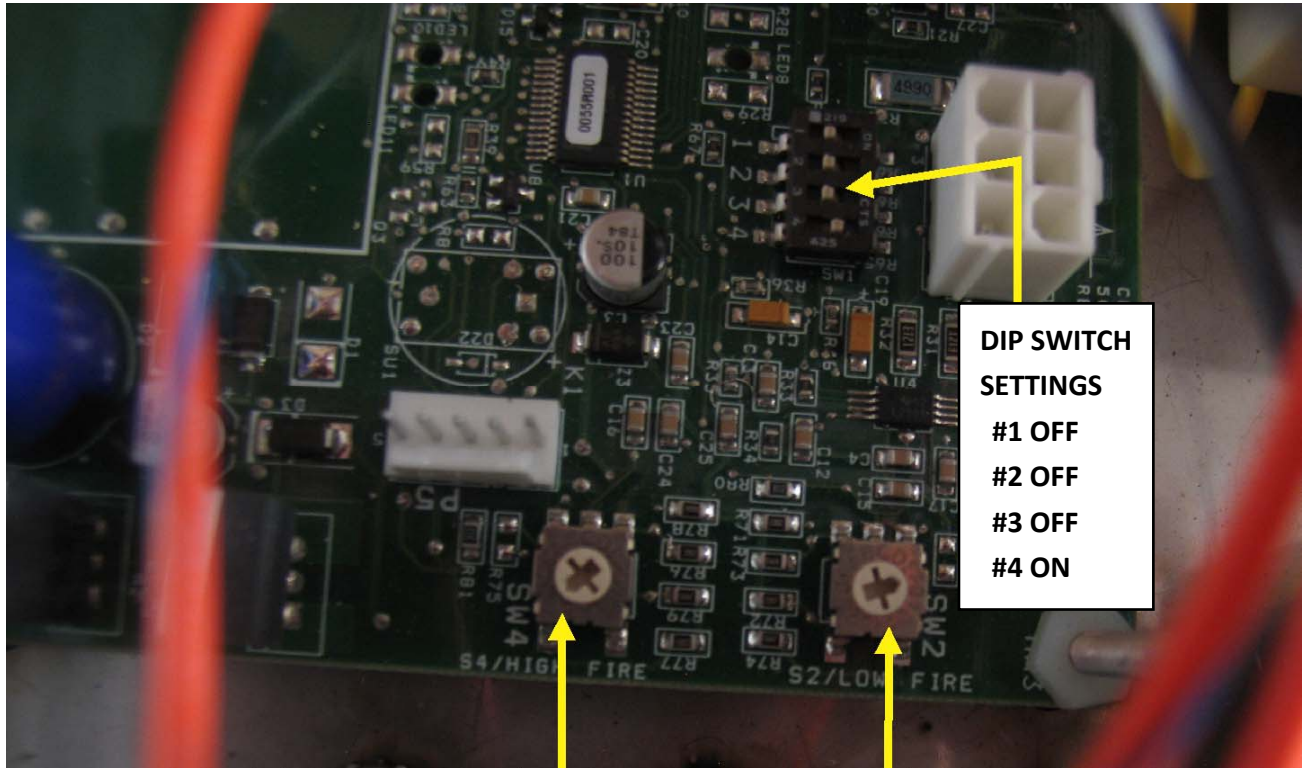

**DIP SWITCH  
SETTINGS**  
#1 OFF  
#2 OFF  
#3 OFF  
#4 ON

**HIGH FIRE = 6**

**LOW FIRE = F**

**Natural Gas**  
Low Fire = F  
High Fire = 6  
**SHOWN**

**Propane**  
Low Fire = 9  
High Fire = B

## 11. LADDER DIAGRAM

### 11.1. LADDER DIAGRAM

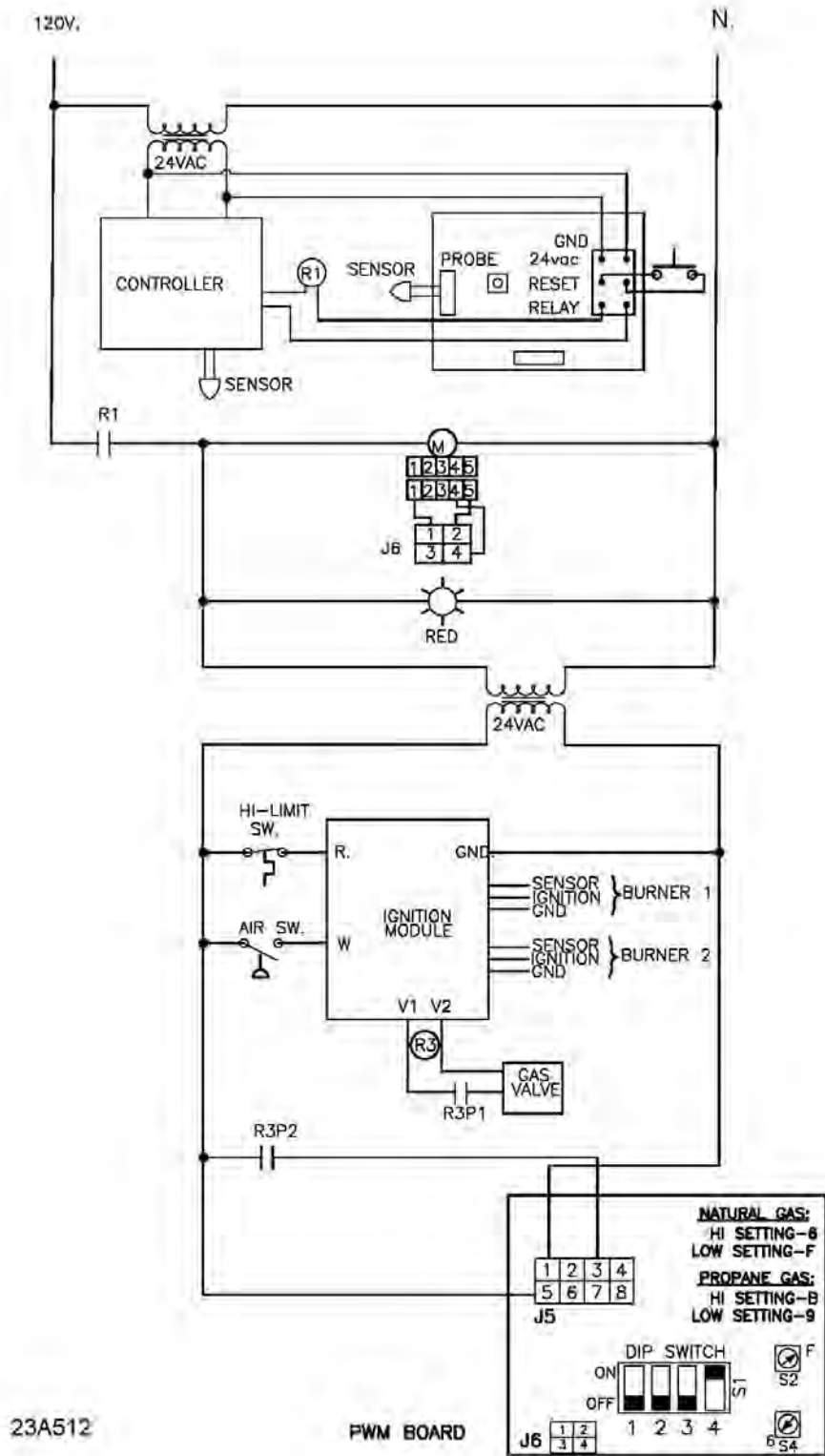

11.2. SCHEMATIC

