



## Model PD14" (356mm) Dual Rated Gas Fryer Operation Instructions



**Ultrafryer Systems**  
**302 Spencer Lane**  
**P.O. Box 5369**  
**San Antonio, TX 78201**

**Local: (210) 731-5000**  
**Toll-Free: (800) 525-8130**  
**Fax: (210) 731-5099**  
**Web: [www.ultrafryer.com](http://www.ultrafryer.com)**



**WARNING!!** TO ASSURE PRODUCING A QUALITY PRODUCT WHILE PROLONGING THE LIFE EXPECTANCY OF THE FRYER, ENSURE FILTERING, BOIL-OUT, AND CLEANING INSTRUCTIONS ARE STRICTLY FOLLOWED.

## PREFACE

This Manual was written and published by the Engineering Department, Ultrafryer Systems for use by personnel who will operate and maintain the Ultrafryer 14" Model PD Stand Alone Gas Fryer equipped with an Ultrastat 25 Computer. Proper use of this Manual will allow store employees to operate, clean, and maintain this equipment properly, thereby reducing service call expenses.

ENGINEERING DEPARTMENT  
ULTRAFRYER SYSTEMS  
302 SPENCER LANE  
SAN ANTONIO, TX 78201

**Please read all sections of this manual and retain for future reference.**

**This product has been certified as commercial cooking equipment and MUST be installed by professional personnel as specified. Installation, maintenance, and repairs should be performed by your ULTRAFRYER FACTORY AUTHORIZED SERVICE CENTER.**



### **DANGER**

**Do not store or use gasoline or other flammable vapors and liquids in the vicinity of this or any other cooking appliance.**



### **DANGER**

**Instructions explaining procedures to be followed MUST be posted in a prominent location in the event the operator detects a gas leak. This information can be obtained from the local gas company or gas supplier.**



### **WARNING**

**Improper installation, adjustment, alteration, service, or maintenance can cause property damage, injury, or death. Read the installation, operating, and maintenance instructions thoroughly before installing or servicing this equipment.**

## TABLE OF CONTENTS

	PAGE
GENERAL INFORMATION	
Warranty.....	6
Safety.....	7
Description / Specifications .....	7
Dimensions & Operational Requirements .....	8
Operating Controls .....	9
Automatic Safety Features .....	10
Rating Plate.....	10
Inlet Gas Line Sizing .....	11
Inlet Gas Requirements.....	11
PRE-INSTALLATION	
General .....	13
Standards .....	13
Air Supply & Ventilation.....	13
RECEIVING & INSTALLING	
Unpacking.....	15
Installing.....	15
Leveling.....	15
Gas Connection .....	16
Electrical Connection .....	16
Ultrastat 25 Cooking Computer .....	17
INITIAL STARTUP	
Cleaning .....	19
Startup.....	19
Lighting Instructions.....	19
Sequence Of Ignition.....	19
Burner Operation Test.....	19
Shortening Installation .....	19
Startup and Cooking.....	20
PREVENTIVE MAINTENANCE AND TROUBLESHOOTING	
Preventive Maintenance .....	22
Troubleshooting .....	23
Troubleshooting Chart .....	24

TABLE OF CONTENTS.....Continued

	PAGE
CLEANING	
General .....	25
Daily .....	25
Weekly.....	25
FRYER OPERATION	
General .....	27
Ultrastat 25 Cooking Computer .....	28
Ultrastat 25 Cooking Computer Operation .....	30
Ultrastat 25 Cooking Computer Programming.....	31
Shortening Installation .....	32
Start-Up And Cooking .....	34
TECHNICAL ASSISTANCE & ORDERING INFORMATION	
Technical Assistance .....	36
Ordering Information.....	36
RECOMMENDED SPARE PARTS.....	38
PARTS IDENTIFICATION	
Parts Identification .....	40
Air Switch Adjustment .....	43
WIRING DIAGRAM .....	45

GENERAL INFORMATION

**ULTRAFRYER® LIMITED WARRANTY: IN-N-OUT BURGER – PDE VAT**

Ultrafryer Systems warrants to the original purchaser of a gas or electric Ultrafryer® sold within the United States, its territories and Canada, that it will be free of defects in material and workmanship for the periods listed below:

**STAINLESS STEEL FRYER VAT** – Stainless Steel fryer vats are warranted for (10) ten years upon the terms hereinafter described. The (10) ten year warranty coverage applies ONLY to the Stainless Steel fryer vat and does not apply to the other components such as controls, burner, gaskets, mounting hardware, or the baffles. The (10) ten year limited warranty coverage for the Stainless Steel fryer vats are as follows: (1) Vats that fail due to faulty workmanship or materials within the first sixty (60) months from the date of shipment will be exchanged at no cost. The cost of labor to install the replacement vat will be covered by Ultrafryer Systems for vats, which fail within twelve (12) months from the date of initial start up. Labor for vat replacements after the first year is the responsibility of the owner (2) Vats that fail within the sixth through eighth year will be exchanged at 50% of current selling price of said vat FOB San Antonio. (3) Vats that fail within the ninth through tenth year will be exchanged at 70% of the current selling price of said vat FOB San Antonio. (Example: If the current selling price for a particular vat is \$2,000.00, then a failure during the sixth through eighth year would be exchanged for \$1,000.00; if the failure occurred in the ninth or tenth year it would be exchanged for \$1,400.00.) Proper credit issue for vat failures is contingent upon receipt, by Ultrafryer Systems, of the serial number identification tag for any failed vat.

**ULTRAFRYER PARTS** – All parts on the Ultrafryer® are covered for a period of one (1) year from the initial date of start up. This is to include gas valves, switches, thermostats, etc. Ultrafryer Systems reserves the right to charge for certain parts such as computers, filter pumps and motors or any item over the amount of \$100.00 until Ultrafryer Systems receives the defective part back. **After inspection, credit for the part will be issued to the purchaser provided the part is deemed defective and that defect is not the result of neglect or abuse by the user.** The shortening filtration system, (hoses) are warranted for ninety (90) days from the initial date of start up.

**PROCESSING WARRANTY CLAIMS** – The equipment owner must promptly notify Ultrafryer Systems Warranty Department of any alleged defects as soon as they are discovered by calling 1-800-525-8130. After such notice, the Warranty Department will perform its obligation under this warranty within a commercially reasonable period of time. If alleged defects develop after normal business hours, on weekends or on holidays the owner must call Ultrafryer Systems first at the above number. This number is monitored 24 hours a day, 7 days a week. Ultrafryer Systems will notify an authorized service agent to make repairs during normal hours or after hours. Any parts that need to be shipped back to Ultrafryer Systems will be shipped back **prepaid by the customer** marked with the processing number and to the attention of the WARRANTY DEPARTMENT.

**NON WARRANTY COVERAGE** – This warranty does not include coverage for any consequential cost of damages including, but not limited to, any loss in store sales, spoiled food products, transportation, duty or custom cost. This warranty does not cover the Ultrafryer® exported to countries outside the United States and its territories. This warranty does not cover original installation and adjustments such as leveling, calibrations and electrical and gas connections. This warranty does not cover travel over 100 miles or 2 hours driving time from the location of the Ultrafryer® or overtime or holiday charges unless the Warranty Department granted prior approval. This warranty does not cover damage due to misuse, abuse, alteration or accident. This Warranty does not cover improper or unauthorized repair or installation, damage in shipment, normal maintenance items such as gaskets, hoses, and exterior finishes. Ultrafryer Systems will begin the fryer warranty one week after shipment but will adjust the warranty upon receiving approved documentation. We reserve the right to void component part warranty on any Ultrafryer that is stored more than six (6) months after shipment from Ultrafryer Systems and not put into service.

**LABOR COVERAGE** – The cost for labor to replace parts are covered for one (1) year after the initial start up. **The Warranty Department must be promptly notified of any defects within the first year of operation.** The labor warranty does not include the cost to repair or clear dirty filter systems or perform any adjustments that would normally fall under the tasks associated with a proper start up and/or demonstration. **Labor is covered by Ultrafryer Systems for repairs by an AUTHORIZED service agent.** Owner is responsible for all costs associated with fryer installation and start up unless prior arrangements have been made with Ultrafryer Systems.

**DISCLAIMER OF WARRANTIES**

Other than as stated herein, ULTRAFRYER SYSTEMS makes no warranty of any kind, express or implied, including but not limited to any warranty of merchantability of fitness for a particular purpose, including trade usage. Ultrafryer Systems' sole obligation, and purchaser's sole remedy, under this warranty is repair or replacement, at the discretion of Ultrafryer Systems, of any part or component that proves to be defective in materials or workmanship. In no event shall Ultrafryer Systems be liable for consequential, incidental, or special loss or damages arising from the use of, or inability to use, the ULTRAFRYER®. This limited warranty is the only and complete statement with respect to warranties of NEW Ultrafryer® PAR-3 Gas ULTRAFRYERS® sold after June 1<sup>st</sup>, 2000. There are no other documents or oral statements for which Ultrafryer Systems will be responsible. Effective 3-1-2008.

## B. SAFETY

The major safety concern associated with the Ultrafryer gas fryer is burns from hot shortening. In order to prevent serious burns, good housekeeping habits are required. The floor in front of and the area around the fryer should be kept clean and dry. Whenever anything is placed into a fryer vat, care should be used not to splash the hot shortening. Product should always be “PLACED” into the shortening, not thrown. Safety goggles, neoprene insulated gloves, and an apron must be worn while boiling-out a fryer vat. Electrical controls used in the gas fryer operate on 120 volts single phase electrical power, and no adjustments or replacement of electrical controls should ever be attempted without first disconnecting electrical power. The fryer should never be operated with wet hands or while standing in water. To do so can result in serious electrical shock or death.

## C. DESCRIPTION



**ULTRAFRYER 14" (356 mm) PD14 GAS FRYER**

The Ultrafryer 14" (356 mm) PD gas fryer was designed by Ultrafryer Systems® to operate as an energy-efficient, gas-fired fryer and is design-certified by the Canadian Standards Association (CSA) and the National Sanitation Foundation (NSF). It is manufactured to operate on either NATURAL, BUTANE, or PROPANE gas according to the following Operational Requirements. Each fryer is shipped completely assembled with the accessories packed inside the fryer vat, and each fryer has been adjusted, tested and inspected prior to shipment. This gas fryer is designed to be used in a commercial food preparation environment after it is properly installed as outlined in this manual.

D. SPECIFICATIONS

MODEL 14" (356 mm) PD GAS FRYER  
OPERATIONAL REQUIREMENTS

SPECIFICATION ITEM		14" PD
Overall Width		14 3/4" (375 mm)
Overall Depth		35" (889 mm)
Work Height		34" (864 mm)
Oil Capacity	High Level	55 Lbs (27.5 Liters)
	Low Level	42.5 Lbs (21.3 Liters)
Size Vat Container		14" x 14" (356 x 356 mm)
Gas Valve Pressure	Natural Gas	4.2" (107 mm) W.C.
	Butane	10.1" (257 mm) W.C.
	Propane	10.0" (254 mm) W.C.
Orifice Drill Size	Natural Gas (105k)	#10
	Natural Gas (95k)	#13
	Butane (105k)	#33
	Butane (95k)	7/64
	Propane (105k)	#31
	Propane (95k)	3.0mm
Gas Rating	Natural Gas	105,000 BTU/hr (111 MJ/hr) / 95,000 BTU/hr (100 MJ/hr)
	Butane	105,000 BTU/hr (111 MJ/hr) / 95,000 BTU/hr (100 MJ/hr)
	Propane	105,000 BTU/hr (111 MJ/hr) / 95,000 BTU/hr (100 MJ/hr)
Inlet Flow Required At STP	Natural Gas	105 FT <sup>3</sup> /hr (3.0 M <sup>3</sup> /hr) / 95 FT <sup>3</sup> /hr (2.7 M <sup>3</sup> /hr)
	Butane	33 FT <sup>3</sup> /hr (.9 M <sup>3</sup> /hr) / 30 FT <sup>3</sup> /hr (0.84 M <sup>3</sup> /hr)
	Propane	42 FT <sup>3</sup> /hr (1.2 M <sup>3</sup> /hr) / 38 FT <sup>3</sup> /hr (1.0 M <sup>3</sup> /hr)
Shipping Cube		13.32 FT <sup>3</sup> (.36 M <sup>3</sup> )
Shipping Weight		185 lbs (84 kgs)
Power Input		120 Volt 36 Amp 60 Hz 1 Ø

FT<sup>3</sup> / HR (M<sup>3</sup>/HR) VALUES May vary due to heating value and specific gravity of gas supplied by local Gas Company

**NOTE:**  
TEST START-UP, OPERATIONS, COOKING, FILTERING, AND BOIL OUT PROCEDURES OF A 14" MODEL PD GAS FRYER IN THIS MANUAL ARE BASED ON A ULTRASTAT 25 (30A051) COOKING COMPUTER. REFER TO MANUAL PN 30A053, ULTRASTAT 11 COOKING COMPUTER OPERATING INSTRUCTIONS; OR MANUAL PN 30A009, ULTRASTAT 21 COOKING COMPUTER OPERATING INSTRUCTIONS; OR MANUAL PN 30A066, DEFAULT-TO-MANUAL-RESTART (DTMR) CONTROLLER OPERATING INSTRUCTIONS TO PERFORM THESE FUNCTIONS IF A PD14 FRYER WITH A COOKING COMPUTER OTHER THAN THAT LISTED IN THIS MANUAL.

**ADDENDUM SHEET #1 for PD-14" GAS FRYER MANUAL PAGES 8 & 11**

**PD-14 Inlet Gas & Operational Requirements With Cast Burner\***

<b>MODEL</b>	<b>GAS TYPE</b>	<b>NOMINAL INPUT RATE</b>	<b>ORIFICE DRILL SIZE</b>	<b>PRESSURE (W.C.)</b>	<b>INLET FLOW @ STP</b>
PD-14 H	Natural	105,000 BTU's/Hr (111Mj/hr)	#10	4.0 in. (102 mm)	105FT <sup>3</sup> /hr (3.0M <sup>3</sup> /hr)
	Propane	105,000 BTU's/Hr (111Mj/hr)	#31	10.0 in. (254 mm)	105FT <sup>3</sup> /hr (3.0M <sup>3</sup> /hr)
	Butane	105,000 BTU's/Hr (111Mj/hr)	#33	10.0 in. (254 mm)	105FT <sup>3</sup> /hr (3.0M <sup>3</sup> /hr)
PD-14	Natural	100,000 BTU's/Hr (106Mj/hr)	#12	4.0 in. (102 mm)	100FT <sup>3</sup> /hr (2.8M <sup>3</sup> /hr)
	Propane	N/A	N/A	N/A	N/A
	Butane	N/A	N/A	N/A	N/A
PD-14 L	Natural	95,000 BTU's/HR (100Mj/hr)	#13	4.0 in. (102 mm)	95FT <sup>3</sup> /hr (2.7M <sup>3</sup> /hr)
	Propane	95,000 BTU's/HR (100Mj/hr)	3.0 mm	10.0 in. (254 mm)	38FT <sup>3</sup> /hr (1.0M <sup>3</sup> /hr)
	Butane	95,000 BTU's/HR (100Mj/hr)	7/64"	10.0 in. (254 mm)	30FT <sup>3</sup> /hr (0.84M <sup>3</sup> /hr)

\*NOTE: Rate values may vary due to heating values and specific gravity of gas supplied by local gas companies.

PD-14L is low input rate, PD-14 is standard input rate, PD-14H is high input rate.

E. OPERATING CONTROLS LOCATION

MODEL 14" PD  
GAS FRYER



Controller Door  
Ultrastat 25  
Cooking Computer

Red Heating  
Indicator Lamp

Service Access  
Door



High Limit  
Switch Reset  
Button

Temperature  
Probe



Drain Ball  
Valve

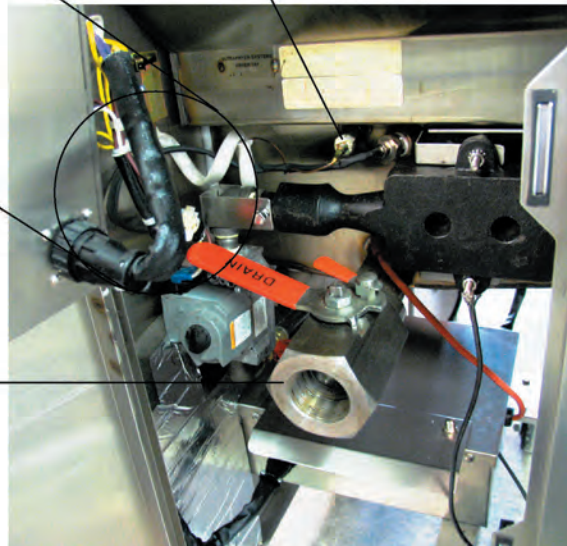

F. OPERATING CONTROLS:

The fryer is equipped with an Ultrastat 25 Cooking Computer as shown below. Operating instructions for the Ultrastat 25 Cooking Computer (PN 30A051) will be provided with the fryer. Operating controls on the fryer include the Ultrastat 25 Cooking Computer and the RED Heating Indicator Lamp. These controls are mounted on the Controller door; and the temperature probe , main drain valve, and other fryer controls are located behind the access door. These controls were identified in the illustrations shown on the previous page.



G. AUTOMATIC SAFETY FEATURES:

1. High limit thermostat to shut off gas to the main burners by opening a solenoid-actuated safety valve in the combination gas control valve.
2. Combination gas control valve which includes a built-in pressure regulator and manual valve.
3. Air pressure switch to open the 24 volt electrical circuit to the combination gas control valve, which turns gas to the fryer OFF if a Blower Motor becomes inoperable.
4. Sensing circuit within the spark ignitor module to which turns gas to the fryer OFF if a burner FLAME OUT occurs.
5. A Current Sensor and Air Pressure switch which, combined, provide an Air Proofing System for the fryer.
6. A Drain Valve Safety Switch that will turn the gas to the fryer OFF each time the drain valve is Opened.

H. RATING PLATE:

The Rating Plate is located on the inside of the Service Access door and contains the following information: the model and serial numbers, BTU/HR input rating of the burners, gas manifold pressure in inches W.C. , minimum inlet gas required, orifice size, and gas type. This data is essential for proper identification when communicating with ULTRAFRYER SYSTEMS or requesting special parts or information.

 **DANGER**  
**THE FRYER MUST BE CONNECTED ONLY TO THE TYPE OF GAS IDENTIFIED ON THIS RATING PLATE!**

I. INLET GAS LINE SIZING:

The Table below is to be utilized to calculate the size (diameter) of the inlet gas line from the building regulator to the fryer manifold.

INLET GAS LINE REQUIREMENTS									
PIPE LENGTH	PIPE DIAMETERS (inches & (mm equivalents))								
	Maximum Allowable Flow (Shown in ft <sup>3</sup> /hr (M <sup>3</sup> /hr))								
Feet (Meters)	½" (13 mm)	¾" (19mm)	1" (25mm)	1¼" (32mm)	1½" (38mm)	2" (51mm)	2½" (64mm)	3" (76mm)	4" (102mm)
15 (4.6)	62 (1.7)	170 (4.7)	350 (9.8)	620 (17.4)	960 (26.9)	2,000 (56.0)	3,500 (98.0)	5,400 (151.2)	11,200 (313.6)
30 (9.1)	43 (1.2)	120 (3.4)	245 (6.9)	430 (12.0)	680 (19.0)	1,400 (39.2)	2,450 (68.6)	3,800 (106.4)	7,900 (221.2)
45 (13.7)	35 (1.0)	98 (2.7)	200 (5.6)	355 (9.9)	530 (14.8)	1,150 (32.2)	2,000 (56.0)	3,200 (89.6)	7,900 (182.0)
60 (18.3)	30 (0.8)	84 (2.4)	175 (4.9)	310 (8.7)	480 (13.4)	1,000 (28.0)	1,760 (49.3)	2,700 (75.6)	5,600 (156.8)
75 (22.9)	27 (0.8)	76 (2.1)	155 (4.3)	275 (7.7)	430 (12.0)	890 (24.9)	1,560 (43.7)	2,450 (68.6)	5,000 (140.0)
90 (27.4)	25 (0.7)	70 (2.0)	145 (4.1)	250 (7.0)	395 (11.1)	810 (22.7)	1,430 (40.0)	2,260 (63.3)	4,550 (127.4)
105 (32.0)	23 (0.6)	64 (1.8)	132 (3.7)	232 (6.5)	370 (10.4)	750 (21.0)	1,300 (36.4)	2,100 (58.8)	4,200 (117.6)
120 (36.6)	21 (0.6)	60 (1.7)	125 (3.5)	215 (6.0)	340 (9.5)	700 (19.6)	1,200 (33.6)	1,950 (54.6)	4,000 (112.0)
150 (45.7)	19 (0.5)	54 (1.5)	110 (3.1)	195 (5.5)	310 (8.7)	630 (17.6)	1,080 (30.2)	1,750 (49.0)	3,550 (99.4)
180 (54.9)	17 (0.5)	49 (1.4)	100 (2.8)	175 (4.9)	280 (7.8)	570 (16.0)	960 (26.9)	1,600 (44.8)	3,200 (89.6)
210 (64.0)	16 (0.4)	44 (1.2)	94 (2.6)	165 (4.6)	260 (7.3)	530 (14.8)	890 (24.9)	1,450 (40.6)	3,000 (84.0)
240 (73.2)	15 (0.4)	43 (1.2)	88 (2.5)	155 (4.3)	240 (6.7)	500 (14.0)	840 (23.5)	1,350 (37.8)	2,800 (78.4)
270 (82.3)	14 (0.4)	40 (1.1)	83 (2.3)	145 (4.1)	230 (6.4)	470 (13.2)	780 (21.8)	1,300 (36.4)	2,650 (74.2)
300 (91.4)	14 (0.4)	38 (1.1)	79 (2.2)	138 (3.9)	215 (6.0)	440 (12.3)	750 (21.0)	1,250 (35.0)	2,500 (70.0)
450 (137.2)	11 (0.3)	31 (0.9)	64 (1.8)	112 (3.1)	176 (4.9)	360 (10.1)	630 (17.6)	1,000 (28.0)	2,050 (57.4)
600 (182.9)	10 (0.3)	27 (0.8)	56 (1.6)	97 (2.7)	152 (4.3)	315 (8.8)	530 (14.8)	860 (24.1)	1,750 (49.0)

NOTE: 1) FT<sup>3</sup>/HR (M<sup>3</sup>/HR) values may vary due to heating value and specific gravity of gas supplied by local companies.  
 2) To determine the inlet gas line diameter for the distance between the fryer and main gas regulator, locate the FT<sup>3</sup>/HR (M<sup>3</sup>/HR) of gas required for the fryer and pipe length and read the pipe diameter on the top row. For example: a 14" PD fryer operating on NATURAL GAS requires 105 FT<sup>3</sup>/HR (3.0 M<sup>3</sup>/HR) of gas at the fryer's inlet gas manifold. If the fryer bank is located 60 feet from the building gas regulator, a 1" (25mm) diameter gas line **MUST** be installed between the manifold and regulator.

J. INLET GAS REQUIREMENTS

INLET GAS REQUIREMENTS								
14" (356mm) IN-N-OUT								
VAT SIZE Model ZRT3-H IN MM	GAS TYPE	GAS VALVE PRESSURE (WC)		ORIFICE HOLE SIZE	RATING		INLET GAS FLOW AT STP	
		IN	MM		BTU/HR	MJ/HR	FT <sup>3</sup> /HR	M <sup>3</sup> /HR
14" (356)	Butane	10.1	(257)	#33 7/64	105,000 (111) 95,000 (100)		33 (90) 30 (84)	
	Natural	4.2	(107)	#10 #13	105,000 (111) 95,000 (100)		105 (3.0) 95 (2.7)	
	Propane	10.0	(254)	#31 3.0mm	105,000 (111) 95,000 (100)		42 (1.2) 38 (1.0)	

The Flexible Gas Line used to connect the gas manifold to the building gas supply line must be rated for the BTU/Hr (MJ/Hr) designated for the Fryer. Flexible gas lines and their ratings stocked by Ultrafryer Systems are listed below:

FLEXIBLE GAS LINES STOCKED BY ULTRAFRYER SYSTEMS			
NUMBER	DESCRIPTION	RATING	
		BTU/HR	(MJ/HR)
24322	¾" (19mm) Diameter Flexible Gas Line (w/quick connect couplings) 48" (1219mm) long. Connect-It SSGC75-48-UCQ	225,000	(238)
24323	1" (25mm) Diameter Flexible Gas Line (w/quick connect couplings) 48" (1219mm) long. Connect-It SSGC100-48-UCQ	435,000	(459)
24456	1¼" (32mm) Diameter Flexible Gas Line (w/quick connect couplings) 48" (1219mm) long. Connect-It SSGC125-48-UCQ	875,000	(924)

PRE-INSTALLATION

- A. GENERAL: Safe and satisfactory operation of a gas fryer depends on its proper installation. Installation must conform to local codes or, in the absence of local codes, with the current National Fuel Gas Code ANSI Z223.1 (latest edition). In Canada, gas installation shall be in accordance with the current CAN/CGA B 149.1 and .2 installation codes and/or local codes.

Each gas fryer should be installed as follows:

1. Placed beneath a properly designed exhaust hood
2. Installed by a licensed plumber.
3. Connected to the type of gas for which the unit was fabricated as shown on the rating plate.
4. Connected to the proper size pressure regulator installed in the gas supply line and adjusted to the proper manifold pressure.
5. Connected to the main gas supply line with the proper size supply line.
6. Restrained by use of a restraining device to avoid splashing of hot liquid and to assure tension cannot be placed on the gas or electrical connections. CLEARANCES: The appliance must be kept free and clear of all combustibles. The minimum clearance from combustible and non-combustible construction is 6" (152 mm) from the sides, and 6" (152 mm) from rear. The fryer may be installed on combustible floors.

NOTE: Adequate clearances must be provided for servicing and proper operation.

- B. STANDARDS: Installation must be planned in accordance with all applicable state and local codes, taking into account the following standards:
1. The fryer and its individual shut-off valve must be disconnected from the gas supply piping system during any pressure testing of that system at pressures in excess of ½ psig (3.45kPa). In Canada, gas installation shall be in accordance with the current CAN/CGA B 149.1 and .2 installation codes and/or local codes.
  2. The fryer must be isolated from the gas supply piping system by closing its individual manual shut-off valve during any pressure testing of the gas supply piping system at pressures equal to or less than ½ psig (3.45kPa).
  3. When installed the fryer must be electrically grounded in accordance with local codes, or in the absence of local codes, in accordance with the current National Electrical code ANSI/NFPA 70 (latest edition). In Canada electrical installation must be in accordance with the current Canadian Electrical Code CSA C22.1 and CSA C22.2 as applicable.
  4. Other applicable nationally recognized installation standards such as:
    - a. National Fuel Gas Code ANSI Z223.1 (latest edition)  
American Gas Association  
1515 Wilson Blvd.  
Arlington, VA22209
    - b. NFPA Standards #54, #94 and #221 (latest edition)  
National Fire Protection Association  
470 Atlantic Avenue  
Boston, MA 02110
    - c. ANSI Z21.69/CAN/CGA-6.16 AND Z21.41/CAN1 6.9
  5. Exhaust hood, when installed must conform to the current NFPA 54-1 and Canadian CAN/CGA-1.11 (latest edition)

NOTE: Local building codes will usually not permit a fryer with its open tank of hot oil to be installed immediately next to an open flame of any type, whether a broiler or an open burner or range. Check local codes before beginning installation.

- C. AIR SUPPLY AND VENTILATION: The area around the appliance must be kept clear of any combustible or flammable products and avoid any obstruction to the flow of ventilation air as well as for ease of maintenance and service. NOTHING is to be stored in the interior of the fryer's cabinet except the filter tub assembly.
1. A means must be provided for any commercial, heavy duty-cooking appliance to exhaust combustion wastes outside of the building. It is essential that a fryer be set under a powered exhaust hood or that an exhaust fan be provided in the wall above the unit, as exhaust temperatures are in the vicinity of 400°F (204°C).



**WARNING**

**Strong exhaust fans in a hood or in the overall air conditioning system can produce slight air drafts in the room, which can interfere with burner performance and be hard to diagnose. Air movement should be checked during installation and if burner problems persist, make-up air openings or baffles may have to be provided in the room.**

2. Exhaust temperature, in addition to the open tank of hot oil, make the storage of anything on shelving over or behind the fryer unsafe.
3. Filters and drip troughs should be part of any industrial hood, but consult local codes before constructing and installing any hood.
4. Provisions must be made for an adequate supply of fresh air and adequate clearance must be maintained for air openings into the combustion chamber.

RECEIVING AND INSTALLING

- A. UNPACKING: Check that the container is upright. Use an outward prying motion – DO NOT USE A HAMMER - to remove the carton. Check the fryer for visible damage; if such damage has occurred do not refuse shipment, but contact the carrier and file the appropriate freight claims.
- B. INSTALLING: Roll the assembled fryer into the building and to its operating location.

**WARNING: IMPROPER INSTALLATION, ADJUSTMENT, ALTERATION, SERVICE OR MAINTENANCE CAN CAUSE PROPERTY DAMAGE, INJURY, OR DEATH. READ THE INSTALLATION, OPERATING, AND MAINTENANCE INSTRUCTIONS THOROUGHLY BEFORE INSTALLING OR SERVICING THIS EQUIPMENT.**

- C. LEVELING:
  - 1. When the fryer is placed in its operating location, check to be sure it is level. If not, loosen the casters and insert the appropriate number of shim plates between leg and caster plates; then retighten the caster bolts.
  - 2. If the floor is smooth and level, adjust to the high corner and measure with a spirit level. If the floor is uneven or has a decided slope, level the unit with metal shims.

NOTE: A caster may not return exactly to the same position after being moved, which may require re-leveling after each move.

- 3. Connect the gas manifold to the building gas supply line by means of a CSA International APPROVED flexible gas line as shown in the figure below.

NOTE: CONNECT-IT inc. 3/4" (19mm), 1" (25mm) and 1 1/4" (32mm) flexible gas hose 4 feet long (1219mm) with a quick disconnect coupling on one end is available from Ultrafryer Systems under PN 24322 (3/4" (19mm) hose), PN 24323 (1" (25mm) hose) and PN 24456 (1 1/4" (32mm) hose). These hoses are equipped with a fusible link, which melts at 361°F (183°C) that will SHUT OFF the gas supply when it melts. A 44" (1119mm) long restraining device is also available under PN 24324.

**CAUTION: THE BUILDING GAS SUPPLY LINE MUST BE SIZED TO PROVIDE THE VOLUME OF GAS REQUIRED FOR PROPER OPERATION AS EXPLAINED ON THE PREVIOUS PAGE.**

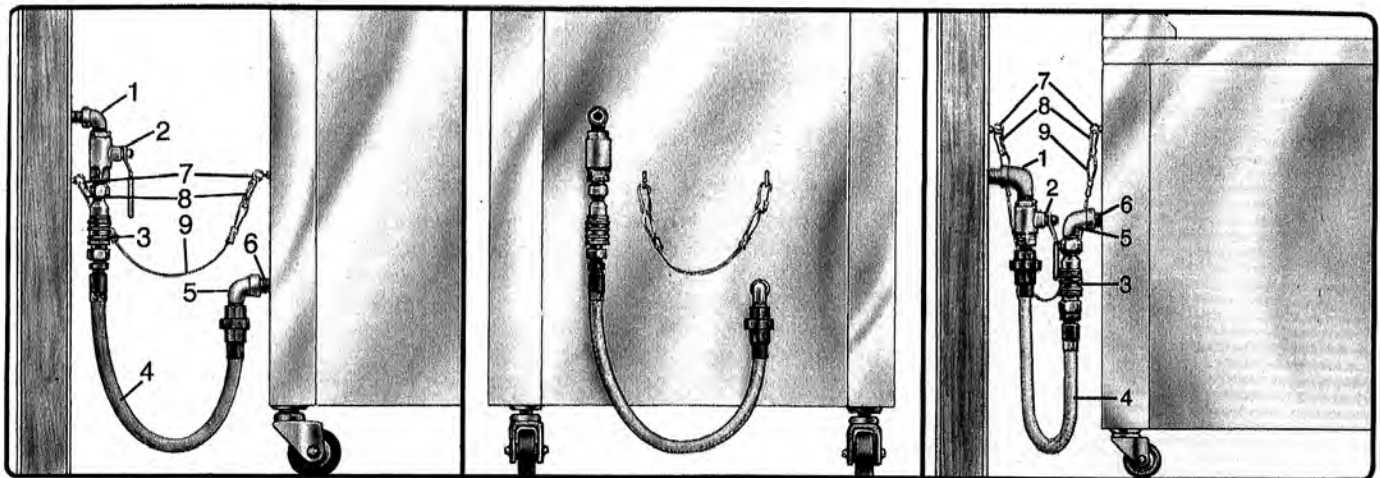

**WARNING: THE RESTRAINT DEVICE (ITEM 9) MUST BE INSTALLED TO ASSURE TENSION CANNOT BE PLACED ON THE GAS OR ELECTRICAL CONNECTIONS**

- |                                                                                                                                                                                                            |                                                                                                                                                                   |
|------------------------------------------------------------------------------------------------------------------------------------------------------------------------------------------------------------|-------------------------------------------------------------------------------------------------------------------------------------------------------------------|
| <ul style="list-style-type: none"> <li>1. BUILDING GAS SERVICE LINE</li> <li>2. MAIN GAS CUT-OFF VALVE</li> <li>3. CONNECT-IT QUICK-DISCONNECT</li> <li>4. FLEX-CON CONNECTOR</li> <li>5. ELBOW</li> </ul> | <ul style="list-style-type: none"> <li>6. APPLIANCE MANIFOLD/NIPPLE</li> <li>7. EYELET FASTENERS</li> <li>8. SPRING HOOK</li> <li>9. RESTRAINING CHAIN</li> </ul> |
|------------------------------------------------------------------------------------------------------------------------------------------------------------------------------------------------------------|-------------------------------------------------------------------------------------------------------------------------------------------------------------------|

- D. **GAS CONNECTION:** The gas supply (service) line must be the same size or greater than the inlet line of the appliance. THE GAS SUPPLY LINES MUST BE SIZED TO ACCOMMODATE ALL THE GAS-FIRED EQUIPMENT THAT MAY BE CONNECTED TO THAT SUPPLY. Refer to the Inlet Gas Line Sizing and Inlet Gas Requirements Tables.



**WARNING**

**Sealant used on all pipe joints must be resistive to butane and propane gas.**

1. Manual shut off valve: The supplier-installed valve must be installed in the gas service line ahead of the appliance and in a position where it can be reached quickly in the event of an emergency.
2. Pressure regulator: All commercial cooking equipment must have a pressure regulator on the incoming service line for safe and efficient operation, because service pressure may fluctuate with local demand. External regulators are not required on this fryer, as that function is performed by a combination gas control valve, however if the incoming pressure is in excess of ½ psig, a step-down regulator will be required.
3. Natural gas: Natural gas fryers require 7" (178mm) water column (W.C.) "inlet" pressure to the fryer's combination gas control valve for proper operation, when all gas units are operating simultaneously. Butane and Propane gas fryers require 14" (56mm) water column (W.C.) "inlet" pressure to the fryer's combination gas control valve for proper operation, when all gas units are operating simultaneously. This "inlet" pressure MUST be checked with a manometer PRIOR to placing the fryer in operation.

**WARNING: IF THE "INLET" GAS PRESSURE AT THE FRYER'S COMBINATION GAS CONTROL VALVE EXCEEDS ½ LB/IN<sup>2</sup> (.035 KG/CM<sup>2</sup>) OR APPROXIMATELY 14" (356 mm) W.C., AN EXTERNAL REGULATOR MAY BE NEEDED TO PREVENT DAMAGE TO THE COMBINATION GAS VALVE AND VOIDING OF THE WARRANTY. FAILURE TO CORRECT THIS CONDITION COULD RESULT IN EXPLOSION OR FIRE.**

4. Combination gas control valve: The correct combination gas control valve and orifice is installed at the factory for BUTANE, NATURAL, and PROPANE units based on each Purchase Order. This valve should be CHECKED/ADJUSTED by qualified service personnel using proper test equipment for the following "OUTLET" gas pressure PRIOR to start-up of a fryer. NATURAL GAS FRYERS 4" (102mm) W.C. BUTANE/PROPANE FRYERS 10" (254mm) W.C.
  5. Rigid connections: Check any installer-supplied intake pipe(s) visually and/or blow them out with compressed air to clear dirt particles, threading chips or any other foreign matter before connecting to the service line as these particles may clog the orifice when gas pressure is applied. All connections must be tested with a soapy solution before lighting the fryer. DO NOT USE AN OPEN FLAME TO CHECK FOR LEAKS! Putting an open flame beside a new connection is not only dangerous, but will often miss small leaks that a soapy solution would find.
  6. Flexible Couplings, Connectors: The installation is to be made with a connector that (1) complies with the Standard for Connectors for Movable Gas Appliances, ANSI Z21.69 (CAN/CGA-6.16), and a quick-disconnect device that complies with the Standard for Quick-Dis-connect Devices for Use With Gas Fuel, ANSI Z21.41 (CAN1-6.9) (2) adequate means must be provided to limit the movement of the fryer without depending on the connector and the quick-disconnect device or its associated piping to limit the movement and (3) the location(s) where the restraining mechanism may be attached to the fryer shall be specified. DOMESTIC CONNECTORS ARE NOT SUITABLE!!!
  7. Fryer Service: The fryer is equipped with swivel casters. To service the fryer:
    - a) Turn "OFF" gas supply at the supply source.
    - b) Disconnect the flexible gas line quick-disconnect
    - c) Disconnect restraint mechanism and roll the fryer out for rear service access.
    - d) When the fryer is repositioned, be sure to reconnect the restraint mechanism and level the fryer.
- E. **ELECTRICAL CONNECTION:** The MAXIMUM current draw per vat at Initial Start-up or during a Warm-up Cycle will be 3 Amperes at 120 Volts. Refer to the wiring diagram located inside the service access door of the fryer for internal electrical connections.



**WARNING**

**(Electrical Grounding Instructions)**

**This appliance is equipped with a three-prong (grounding) plug for your protection against shock hazard and should be plugged directly into a properly grounded three-prong receptacle. Do not cut, remove, or otherwise bypass the grounding prong on this plug!**

## E. ULTRASTAT 25 COOKING COMPUTER

The Ultrastat 25 Cooking Computer is a high performance, microprocessor-based electronic controller designed for use in commercial appliance temperature and timing control applications. Utilizing a microcontroller board, membrane switch front panel with a digital LED readout and display board, the Ultrastat 25 Cooking Computer has been customized for Ultrafryer Systems applications by the addition of up to 10 stage cooking profiles for each of the 8 product keys; exit melt features can be programmed to cook products under “Flex” or “Straight” timing modes. Operation of the Ultrastat 25 Cooking Computer is covered in its Instruction Manual PN 30A051 provided with the Fryer.



ULTRASTAT 25 COOKING COMPUTER

INITIAL STARTUP

- A. **CLEANING:** New units are wiped clean at the factory to remove any visible signs of dirt, oil, grease, etc., remaining from the manufacturing process. Each fryer vessel should be thoroughly washed with hot soapy water to remove film residues, installation dust, or debris; and then wiped dry before being used for food preparation.
- B. **STARTUP:** The fryers are tested, adjusted and calibrated prior to being shipped; however adjustments may be necessary on installation to meet local conditions, high or low gas pressure, differences in altitudes, variations in gas characteristics, and to correct possible problems caused by rough handling or vibration during shipment. Initial calibration or adjustment is the responsibility of the customer and will not be covered by the Ultrafryer Systems warranty.

NOTE: Calibration and adjustments must be performed by qualified personnel.

- C. **LIGHTING INSTRUCTIONS:** Each fryer is equipped with a spark ignition system; to test this system, perform the following steps, in sequence:
  - 1. Ensure the Ultrastat 25 Controller is off.
  - 2. Fill the fryer vessel with hot or cold water to the SHORTENING LEVEL mark.

**CAUTION : IF THE MAIN BURNERS ARE OPERATED WITH THE VESSEL EMPTY, THE HEAT WILL CAUSE THE JOINTS OF THE FRYER VESSEL TO BE PLACED UNDER UNDUE STRESS AND MAY CAUSE THE HEAT EXCHANGER VESSEL TO WARP OR BUCKLE, VOIDING WARRANTY.**

- 3. Turn the manual gas valve behind the fryer service access door of the fryer to the OFF position and wait FIVE (5) minutes for any accumulated gas to disperse.
- 4. ENSURE the MAIN gas shutoff is in the ON position, MANUAL VALVE on the combination GAS CONTROL VALVE (located behind the fryer service access door) is in the ON position, and the Vent Hood EXHAUST FAN is ON.
- 5. Turn the manual gas valve to the ON position.
- 6. Place the ULTRASTAT 25 Cooking Computer into the MELT MODE.

**WARNING!!! DO NOT USE A MATCH OR CANDLE TO LIGHT A FRYER... EVER!**

- D. **SEQUENCE OF IGNITION:** When the lighting instruction steps are performed in the sequence listed above, the following will occur:
  - 1. Blower will come ON, activating the air pressure switch.
  - 2. The air pressure switch will CLOSE completing the electrical circuit to the transformer.
  - 3. The transformer will supply 24 volts to the IGNITOR MODULE and GAS CONTROL VALVE, and the ignitor will SPARK lighting the gas in the burner.

**WARNING!!! WHEN CHECKING FOR BURNER PERFORMANCE, DO NOT STAND WITH YOUR FACE CLOSE TO THE BURNER.... IT MAY LIGHT WITH A "POP" AND COULD FLASH BACK AND CAUSE FACIAL BURNS.**

NOTES: 1) If the burner flame fails, it will be sensed by the SPARK IGNITOR; the Spark Ignitor Module will open the electrical circuit to the GAS CONTROL VALVE, shutting off gas to the burner. 2) If the blower fails, the air pressure switch will open the electrical circuit to the TRANSFORMER, removing electrical power from the SPARK IGNITOR MODULE and GAS CONTROL VALVE, shutting off gas to the burner.

- E. **BURNER OPERATION TEST:** Perform above LIGHTING INSTRUCTIONS and observe operation of the burners. When satisfied that the burner is operating properly, drain the fryer vessel of water and dry the vessel thoroughly; then fill the fryer vessel with shortening according to the instruction, below.
- F. **SHORTENING INSTALLATION:**
  - 1. **LIQUID SHORTENING:** When using liquid shortening fill the fryer with cold shortening 1/2" (13mm) BELOW the "E" in the word LEVEL. When the shortening is heated, ensure it is even with the "E" in the word LEVEL.
  - 2. **SOLID SHORTENING:**
    - a) Cut a block of solid shortening into small pieces.
    - b) Place small pieces of solid shortening EVENLY on top of the HEAT EXCHANGER TUBES or THOROUGHLY PACK these pieces of solid shortening between, below, and above the HEAT EXCHANGER TUBES. While packing solid shortening is messy and time-consuming, it is the fastest way to melt solid shortening.

G. STARTUP AND COOKING

TO TEST OPERATE an Ultrafryer Gas Fryer equipped with an Ultrastat 25 Cooking Computer:

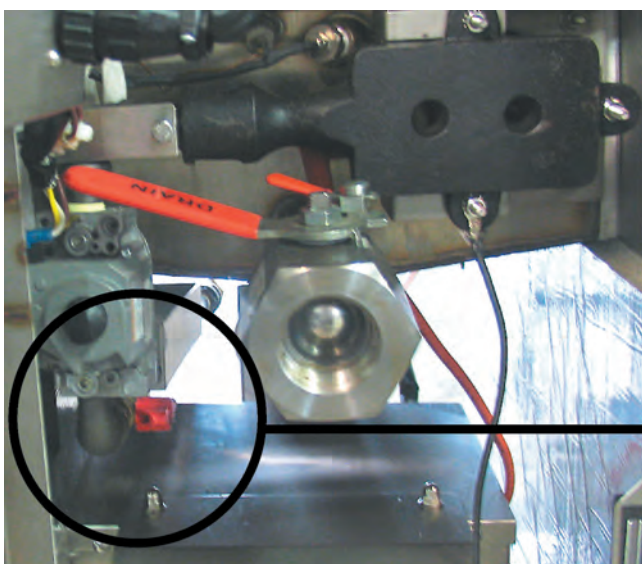

1. Ensure the Computer's ON/OFF Key is in the OFF position.
2. Fill the fryer vat with hot or cold water to the middle of the "E" in the word LEVEL of the applicable shortening level mark on the rear of the vat.
3. Turn the MANUAL gas valve to the OFF position and wait FIVE (5) minutes for any accumulation of gas to disperse.
4. ENSURE the MAIN gas shutoff valve is in the ON position, and that the EXHAUST FAN is ON.
5. Turn the MANUAL GAS VALVE to the ON position.
6. Perform the following steps, in the order listed:



MANUAL GAS VALVE  
UNDER GAS VALVE WITH  
RED KNOB

STEP	ACTION	RESPONSE
1	Ensure the drain valve lever is in the closed position and that water is at the proper level.	

**CAUTION: PRIOR TO PROCEEDING TO STEP 2, VISUALLY CHECK THAT THE HEAT EXCHANGER TUBES ARE COVERED BY AT LEAST 2" (51mm) OF WATER.**

2	Turn the computer ON by pressing the computer ON/OFF key; then place the computer in the BOIL MODE by pressing the computer keys below in that order: 	A. <i>BOIL 30:00</i> will appear in the computer display. B. The <b>HEAT DEMAND LED</b> on the computer and the <b>RED</b> Burner indicator lamp on the fryer will cycle ON and OFF to heat the water to 192°F (89°C).
3	When water begins to <b>BOIL</b> , press the computer key to exit the Boil Mode. 	A. The Computer Display will go <b>BLANK</b> .
4	After the water in the vat and metal surfaces of the fryer has <b>COOLED</b> , drain the water into a floor drain.	

PREVENTIVE MAINTENANCE AND  
TROUBLESHOOTING

A. PREVENTIVE MAINTENANCE

Minimal maintenance is required on a 14" (356 mm) gas fryer because of its design and materials used in the manufacturing process. However, some preventive maintenance and inspection must be performed periodically to prevent breakdowns which could curtail food sales. Any preventive maintenance or inspection should be accomplished with CAUTION while the fryer is in operation since HOT liquid shortening could cause severe burns. If service or repair is required, all gas and electrical power MUST BE TURNED OFF PRIOR TO performing that service or repair.

PREVENTIVE MAINTENANCE SCHEDULE

<u>ITEM</u>	<u>DAILY</u>	<u>INSPECT FOR:</u>
Grease Filters		Clean grease filters in the exhaust vent hood every evening and allow them to dry overnight.

	<u>WEEKLY</u>	
Drain Valve Handle		Determine that the Drain Valve Handle is securely attached to the drain valve, and that the valve can be easily opened and closed.
Temperature Sensing Probes		During boil-out of the fryer, inspect the temperature and high limit sensing probes for any visual damage.

	<u>SEMI ANNUAL</u>	
Agitator Baffle		A qualified technician or authorized service agent is to remove and inspect the agitator baffle in each fryer for metal fatigue or weld deterioration every SIX (6) MONTHS. If no defect is found, reinstall the original baffle.



NOTE: Slight warp or a few broken fins is normal wear. DO NOT REPLACE during Semi-Annual inspection

	<u>ANNUALLY</u>	
Agitator Baffle		Every 12 MONTHS a qualified technician or authorized service agent is to AUTOMATICALLY install a NEW agitator weldment in each fryer.

C. TROUBLESHOOTING

- 1 GENERAL: The problems and possible solutions listed in the troubleshooting chart below are typical problems that are known to occur. ONLY qualified repairmen are to use the troubleshooting chart to repair this fryer. In the event a main burner malfunction occurs, perform the following checks PRIOR to contacting a repairman:
  - a. Ensure Gas Valves are in their proper position.
  - b. Check that the fryer electrical plug is connected to an electrical receptacle.
  - c. Ensure the applicable Circuit Breaker is in the ON position and that the Computer ON/OFF Key is in the ON position.
  - d. Ensure the gas supply line quick-disconnect coupling is SEATED on the gas manifold fitting.
  - e. Determine that both blowers are operating.
  
- 2 TROUBLESHOOTING CHART: Should a problem occur that cannot be corrected after performing the above CHECKS, contact an authorized repairman and/or Ultrafryer Systems Customer Service at 1-800-525-8130 and provide the information acquired while performing these checks.

**CAUTION: DURING MAINTENANCE OR REPAIR, ELECTRICAL POWER AND GAS MUST BE TURNED OFF, AND FRYER RESTRAINTS MUST BE DISCONNECTED/CONNECTED IF A FRYER IS TO BE MOVED WHILE PERFORMING ANY MAINTENANCE OR REPAIR.**

TROUBLESHOOTING CHART																	
PROBLEMS	POSSIBLE SOLUTIONS																
A Main burner will not ignite. Blowers are operating; but gas is not present at the burner.	<ol style="list-style-type: none"> <li>1 Check each Blower air pressure Switch by temporarily disconnecting the two (2) <b>ORANGE</b> air switch wires and connecting them together. If the <b>IGNITOR</b> sparks when these wires are connected, the air pressure switch is defective and it will have to be replaced.</li> <li>2 Check the following components and replace if found to be defective: Transformer Gas Control Valve Hi-Limit Switch</li> </ol>																
B Electrical power is present at the fryer, but a Blower is not operating.	<ol style="list-style-type: none"> <li>1 Blower may have over-heated and shut-off on thermal overload. If this situation did occur, it will correct itself when the blower cools (10-20 minutes). If this overheating problem persists, replace the blower motor.</li> </ol>																
C Excessive time is required to raise the shortening to cooking temperature. Temperature recovery is slow and main burner flames are small and appear to be lethargic.	<ol style="list-style-type: none"> <li>1 Ensure that the <b>MANUAL GAS VALVE</b> is completely open.</li> <li>2 Check for an obstruction in the gas line.</li> <li>3 Check for an obstruction in the flue pipe.</li> <li>4 Check that the <b>ORIFICE PLUG</b> has the correct drill size opening shown below.                             <table style="margin-left: 40px; border: none;"> <tr> <td style="text-align: left;">TYPE GAS</td> <td style="text-align: left;">ORIFICE HOLE SIZE</td> </tr> <tr> <td>Natural</td> <td>#10 (105k) / #13 (95k)</td> </tr> <tr> <td>Butane</td> <td>#33 (105k) / 7/64 (95k)</td> </tr> <tr> <td>Propane</td> <td>#31 (105k) / 3.0mm (95k)</td> </tr> </table> </li> <li>5 Check for damaged <b>BLOWER</b> fins.</li> <li>6 Use a standard water-type U-gauge Manometoer to check the pressure at the gas control valve pressure tap. Proper gas pressure is shown below:                             <table style="margin-left: 40px; border: none;"> <tr> <td style="text-align: left;">TYPE GAS</td> <td style="text-align: left;">GAS VALVE SETTING</td> </tr> <tr> <td>Natural</td> <td>4.2" W.C. (107mm)</td> </tr> <tr> <td>Butane</td> <td>10.1" W.C. (257mm)</td> </tr> <tr> <td>Propane</td> <td>10.0" W.C. (254mm)</td> </tr> </table> </li> <li>7 If necessary remove the Pressure Regulator Adjustment cover and adjust this control to the proper pressure. (Turn adjusting screw <b>CLOCKWISE</b> to increase gas pressure to the burner and <b>COUNTER CLOCKWISE</b> to decrease gas pressure. Replace adjustment cover.)</li> </ol>	TYPE GAS	ORIFICE HOLE SIZE	Natural	#10 (105k) / #13 (95k)	Butane	#33 (105k) / 7/64 (95k)	Propane	#31 (105k) / 3.0mm (95k)	TYPE GAS	GAS VALVE SETTING	Natural	4.2" W.C. (107mm)	Butane	10.1" W.C. (257mm)	Propane	10.0" W.C. (254mm)
TYPE GAS	ORIFICE HOLE SIZE																
Natural	#10 (105k) / #13 (95k)																
Butane	#33 (105k) / 7/64 (95k)																
Propane	#31 (105k) / 3.0mm (95k)																
TYPE GAS	GAS VALVE SETTING																
Natural	4.2" W.C. (107mm)																
Butane	10.1" W.C. (257mm)																
Propane	10.0" W.C. (254mm)																
D Shortening temperature is too high and breaks down quickly.	<ol style="list-style-type: none"> <li>1 Check the gas pressure as described above.</li> </ol>																

CLEANING

A. GENERAL

Any item of equipment operates better and lasts longer when it is kept clean and properly maintained, and the 14" (356 mm) gas fryer is no exception. In order for this fryer to provide years of trouble-free service, it must be CLEANED and MAINTAINED according to the instructions as listed below:

1. DAILY

- a.) Clean the fryer surface periodically during operating hours with a solution of sanitizer and hot water, and at closing with stainless steel cleaner. If necessary, use a dampened type 7447 RED or 7440 BROWN (heavy duty) Scotch brite pad to remove encrusted material. DO NOT use steel wool, abrasive cloths, cleaners, powders, metal knife, spatula or any other metal object to scrape stainless steel! Scratches on stainless steel are almost impossible to remove!
- b.) Filter shortening in each fryer once a day according to Company Policy.

**CAUTION: DO NOT ALLOW ANY CLEANING SOLUTION/WATER TO SPLASH INTO A VESSEL OF HOT COOKING OIL AS IT WILL CONTAMINATE THE OIL AND MAY CAUSE THE OIL TO SPLATTER, CAUSING SEVERE BURNS.**

- c.) THOROUGHLY clean the filter machine according to instructions provided in the cleaning section of this manual.

2. WEEKLY

- a.) BOIL OUT the fryer vat using Boil Out Compound according to procedures in the cleaning manual provided by the chemical supplier.
- b.) Perform steps a) and b) listed above under Daily Cleaning routines.

## FRYER OPERATION

## 1. GENERAL

The PD14 gas fryer is equipped with a Ultrastat 25 Cooking Computer, which turns each fryer ON and OFF, automatically places the fryer in the SHORTENING MELT MODE each time it is turned ON, and controls the COOK CYCLES of each product. The Ultrastat 25 Computer is housed in a 5) Stainless Steel Protective Casing. The following controls are located on the 1) Control Panel Door: the 2) Ultrastat 25 Controller, the 3) RED Heating Indicator. The following controls are located behind the 4) Service Access Door: 7) Drain Valve with 8) Handle, 9) Drain Valve Extension, 6) Combination Gas Valve, 11) Manual Shutoff Valve and 10) Control Box Assembly. The following components are located inside of the Electrical Box Assembly: 12) Spark Ignitor Module, 13) Step-Down Ignition Transformer, 14) Solid State (MAKE/BREAK) Timer, 15) Blower Motor Current Sensor, 16) Computer Step-Down Transformer, and 17) 24 Volt DC Control Relay.

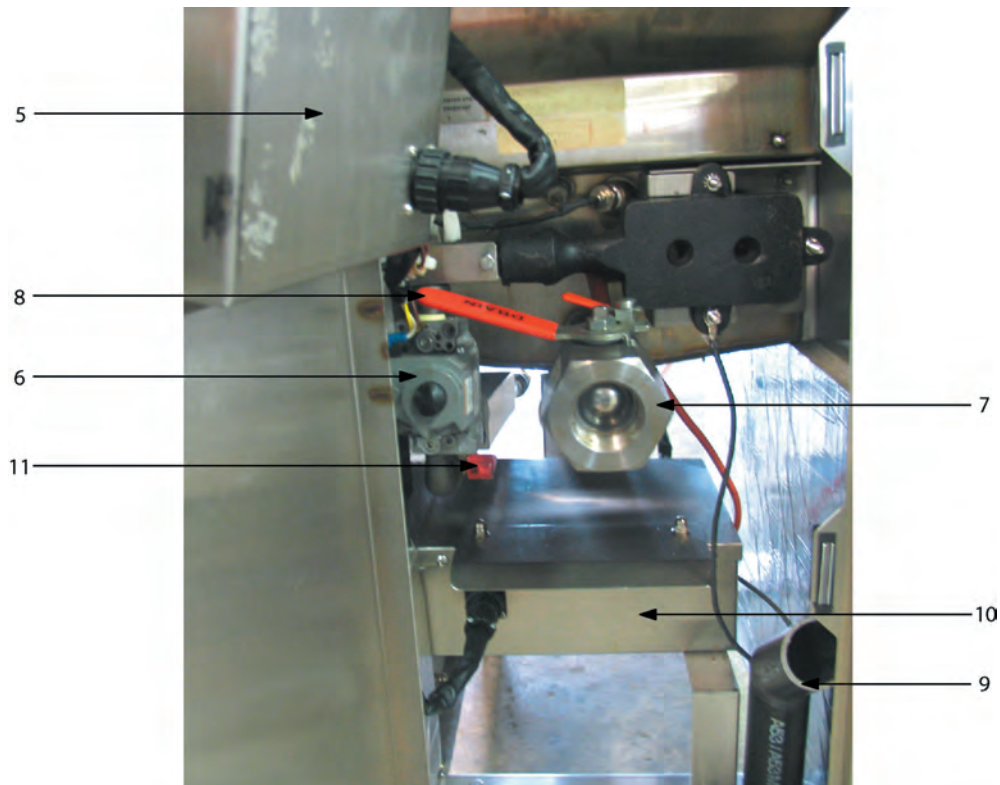
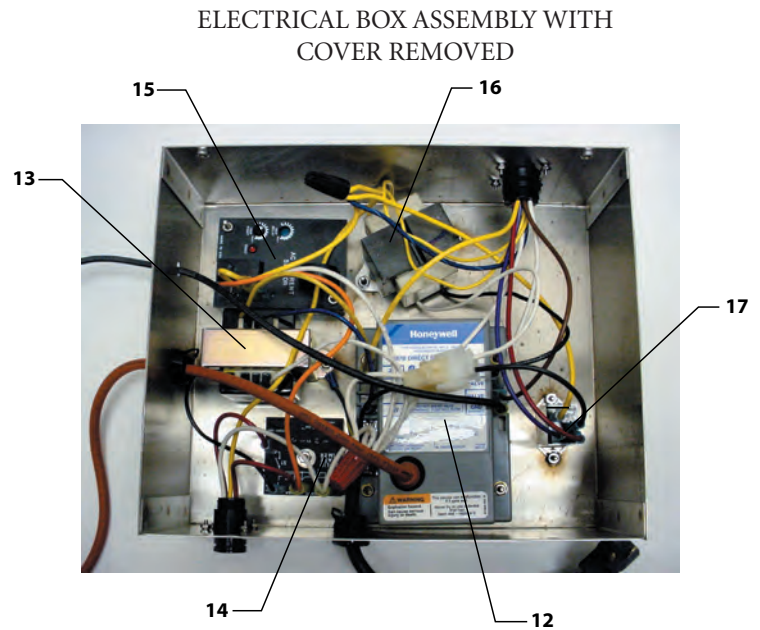
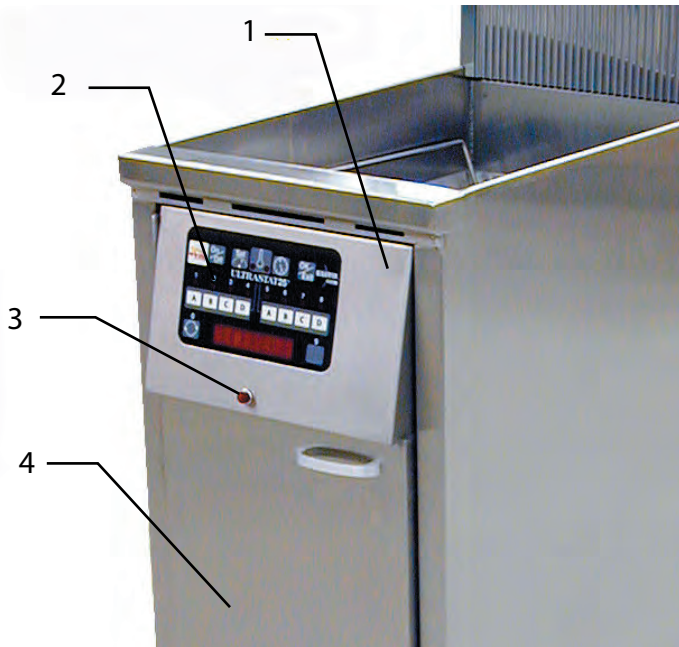

## 2. ULTRASTAT 25 COOKING COMPUTER

The Ultrafryer 14" (356 mm) PD gas fryers is equipped with an Ultrastat 25 Cooking Computer which is connected to the fryer's electrical system to serve as its ON/OFF switch and thermostat as well as providing heat control, status information and product cook timer. When the computer is in operation it will DISABLE the fryer if the drain valve is OPENED.

### A. COMPUTER PANEL KEY DESCRIPTIONS

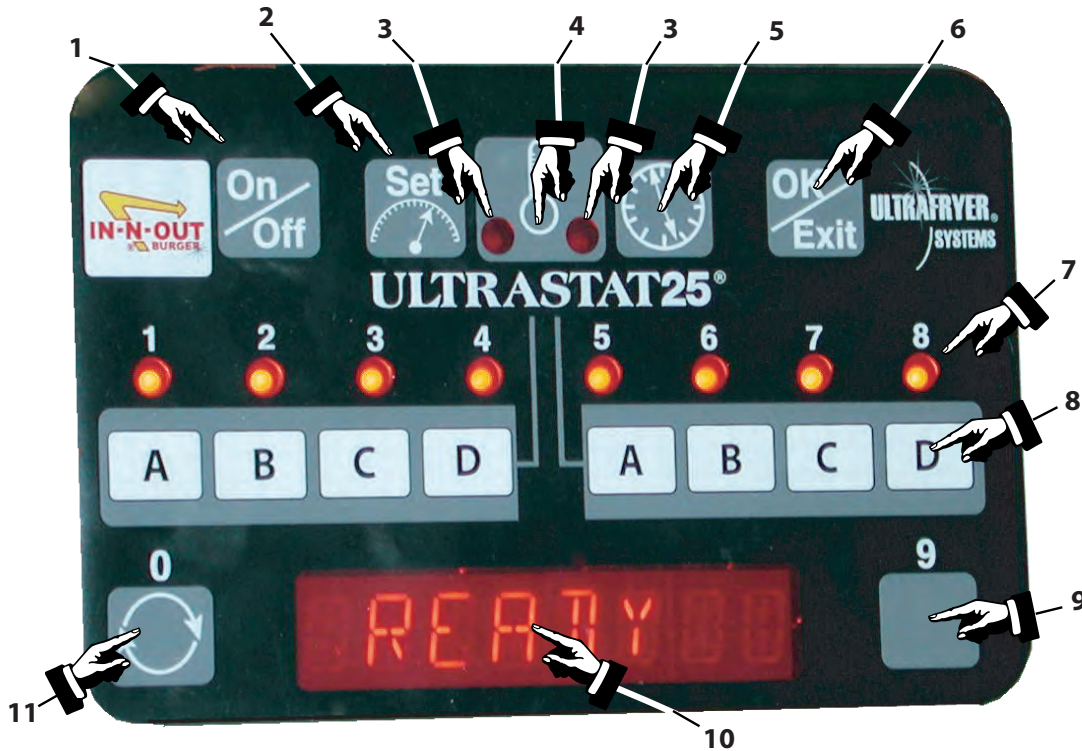

1. ON/OFF KEY  
Turns the Computer ON and OFF when the fryer toggle ON/OFF switch is in the ON position and the drain valve lever in the closed UP position.
2. SET KEY
  - a. In "operating" mode, allows access to the programming mode.
  - b. In "programming" mode, allows access to the operating mode.
3. HEAT DEMAND LEDs  
When lit (bright) indicate the computer is calling for heat.
4. TEMPERATURE KEY
  - a. When pressed one time, displays actual shortening temperature for 3 seconds.
  - b. When pressed two times, within 3 seconds, displays current setpoint temperature for 3 seconds.
  - c. When pressed three times, within 3 seconds, will return to previous display.
5. TIME KEY  
Used to display remaining cook time of a product, activate/abort the recipe display of a product, and starting the Filter Timer.
6. OK/EXIT KEY
  - a. In "operating" mode used to manually exit the shortening melt cycle, exit the Filter Timer, and activate/exit the setback mode.
  - b. In "programming" mode serves as an ACCEPT key.

7. PRODUCT LED
  - a. BLINKING fast in “operating” mode indicates cooking of that product is in process.
  - b. When lit (bright) in “programming” mode indicates the product being programmed.
8. PRODUCT COOK AND PROGRAMMING KEY
  - a. In “operating” mode, used to start and stop a product cook cycle.
  - b. In “programming” mode, used to enter numerical value “3660” and select RECIPE PROGRAMMING MODE.
9. PROGRAMMING KEY
 

In “programming” mode, used to enter the numerical value of 9.
10. DISPLAY
 

Displays modes, functions and operation of the computer.
11. TOGGLE/PROGRAMMING KEY
 





In “programming” mode, used to enter the numerical value of 0 and “toggle” (switch) between choices being displayed.



## B. DISPLAY DESCRIPTIONS

<i>ACT --- F/C</i>	—	The actual shortening temperature in degrees Fahrenheit/Celsius when the  key is pressed, i.e., 100°F (38°C).
<i>--- :---</i>	—	Time remaining in a cook cycle or other computer function, ie., 10:00.
<i>BOIL -- : --</i>	—	Time remaining in the BOIL mode, ie., 20:00.
<i>OFF</i>	—	Indicates the Computer is ready to be turned ON.  NOTE: Computer must be turned OFF by the ON/OFF key before the ON/OFF key can be used to turn the Computer ON.
<i>TURN OFF</i>	—	Prompt to cycle power OFF at the end of the BOIL, FILTER, etc., functions.
<i>TOD LOW</i>	—	Indicates an entered value is too low and is NOT ACCEPTABLE.
<i>TOD HIGH</i>	—	Indicates an entered value is too high and is NOT ACCEPTABLE.
<i>CK 1-8</i>	—	Indicate the specific Product Key number for which the computer is displaying status information during a cook cycle.
<i>STIR 1-8</i>	—	Indicates an action needs to be taken on a product being cooked by a specific product key such as STIR 5.
<i>MELT E</i>	—	Default Electric Melt Cycle - Heating mechanism is ON 4 seconds and OFF 36 seconds.
<i>MELT G</i>	—	Default Gas Melt Cycle - Heating mechanism is ON 8 seconds and OFF 32 seconds.
<i>MELT P</i>	—	Default Purge Melt Cycle - Heating mechanism is ON 12 seconds and OFF 28 seconds.

<i>READY</i>	—	The actual shortening temperature is within 20°F (11°C) of the (SETPOINT) temperature.
<i>LOW</i>	—	The actual shortening temperature is more than 20°F (11°C) BELOW the READY (SETPOINT) temperature.
<i>HIGH</i>	—	The actual shortening temperature is more than 20°F (11°C) ABOVE the READY (SETPOINT) temperature.
<i>HIGH TMP</i>	—	The actual shortening temperature is ABOVE 420°F (216°C). If this occurs the computer will emit a CONTINUOUS ALARM signal.
<i>DONE 1-8</i>	—	Indicates a cook cycle has been completed on a product being cooked by a specific product key, such as DONE 5.
<i>PROBE OP</i>	—	Indicates the computer temperature probe is OPEN . When this occurs; 1) any cook cycle will be CANCELLED ; 2) heating mechanism will be turned OFF and, 3) normal key presses will be INHIBITED.
<i>PROBE SH</i>	—	Indicates the computer temperature probe is SHORTED . When this occurs; 1) any cook cycle will be CANCELLED ; 2) heating mechanism will be turned OFF and, 3) normal key presses will be INHIBITED.

C. ULTRAFRYER 25 COOKING COMPUTER OPERATION

ITEM	ACTION	RESPONSE
1	<p>ENSURE the drain valve lever on the fryer is in the CLOSED position, shortening is at the proper level, then press the ON/OFF  key on the Ultrastat 25 Cooking Computer. </p> <p>The Melt Release Temperature is factory set for a HIGH Exit Temperature (135°F / 57°C) or a LOW Exit Temperature (75°F / 24°C) according to the customers specifications.</p>	<p>A. <i>MELT G/P</i> will appear in the display to indicate the computer is in the SHORTENING MELT MODE.</p> <p>B. The HEAT DEMAND LAMP on the computer and the RED Heating Indicator Lamp on the fryer will cycle ON and OFF indicating the burner is periodically turned ON and OFF to gently heat the shortening.</p>
<p><b>NOTES:</b> 1) The computer will keep the fryer in the MELT MODE until the  OK/EXIT key is manually pressed. 2) The computer CANNOT be taken out of the SHORTENING MELT  MODE until the shortening temperature reaches the MELT RELEASE TEMPERATURE.</p>		
2	<p>Once the Melt Release Temperature is reached, press the OK/EXIT key  to cancel the SHORTENING MELT MODE.</p>	<p>A. LOW will appear in the computer display indicating the shortening temperature is more than 20°F (11°C) below the READY (SET-POINT) temperature.</p> <p>B. The HEAT DEMAND lamp on the computer and the RED Heating Indicator lamp on the fryer will cycle ON and OFF until the Set-Point Temperature is reached.</p>

ITEM	ACTION	RESPONSE
3	When <i>READY</i> appears in the computer display, indicating the <b>SET-POINT TEMPERATURE</b> has been reached: 1) Drop the Product to be cooked. 2) Press the appropriate <b>PRODUCT KEY #</b> (PK #) for the product to be cooked. 	A. The Product Key LED will <b>BLINK FAST</b> and CK (Cook Key) 2 and the correct cooking time will be displayed. The time will immediately start to count-down in minutes and seconds. B. The <b>HEAT DEMAND</b> lamp on the computer and the <b>RED Heating Indicator Lamp</b> on the fryer will cycle ON and OFF to maintain the shortening temperature as programmed.
4	When the Cook Time counts down to <i>00:00</i> indicating the Programmed Cook Time is ended: 1) Press the <b>PRODUCT KEY #</b> to turn the alarm signal <b>OFF</b> and reset the Product Key. 2) Remove the Product from the shortening. 	A. <i>DONE 2</i> will appear in the display indicating the Cook cycle for that Product is ended. B. The computer alarm will sound alerting the cook that the product has been cooked as programmed.
5	Repeat Steps 3 and 4 to cook additional product.	

D. ULTRASTAT 25 COOKING COMPUTER PROGRAMMING - Program the Ultrastat 25 Cooking Computer as follows:

CAUTION: DUE TO THE COMPLEXITY OF AN ULTRASTAT 25 COMPUTER, PROGRAMS SHOULD ONLY BE CHANGED BY AN AUTHORIZED OPERATIONS MANAGER/SUPERVISOR OR A SERVICE AGENT APPROVED BY ULTRAFRYER SYSTEMS' CUSTOMER SERVICE DEPARTMENT.

1. RECIPE PROGRAM DISPLAYS

- PROGRAM* — Indicates computer is in the program mode and allows the customer to select RECIPE programming by entering 3660 (cook password)
- RECIPE* — Indicates computer is in the Recipe programming mode in which product staged cook times and temperatures, and action alarms may be programmed
- TOO HIGH* — Indicates the number of steps, time, temperature, or action alarms entered is too high and is NOT ACCEPTABLE.
- TOO LOW* — Indicates the number of steps, time, temperature, or action alarms entered is too low and is NOT ACCEPTABLE.
- STRAIGHT* — Indicates “straight” cook time has been selected where the product is cooked at a certain temperature for a certain time.
- FLEX* — Indicates “flex” cook time has been selected where the computer adjusts the actual cook time taking into consideration the temperature variations due to load size, initial product temperature, product moisture content, and other factors affecting the cook cycle.
- ALARMS* — Indicates the number of STIR alarms that may be programmed for this Product Key.
- HITS* — Indicates shortening abuse weight factor of the Product Key being programmed.

NOTE: A “programming timeout” will occur if no key is pressed for TWO (2) minutes and the computer will return to normal operations.

2. To program product cook times, and temperatures, perform RECIPE PROGRAMING steps 1 through 8 below.

NOTES: 1. The following steps pertain to programming one (1) Product Key for a gas fryer. 2. A PROGRAMMING TIMEOUT will occur if no keys are pressed for two (2) minutes in the programming mode.

STEP	ACTION	RESPONSE
1	ENSURE the Drain Lever on the fryer is in the <b>CLOSED</b> position, shortening is at the proper level; then press the computer <b>ON/OFF</b> key.	<p>A. <i>MELT</i>, <i>E</i>, <i>G</i>, or <i>P</i> will appear in the display to indicate the computer is in the <b>SHORTENING MELT MODE</b>.</p> <p>B. The <b>HEAT DEMAND</b> lamp on the computer and the <b>RED HEATING INDICATOR</b> lamp on the fryer will cycle <b>ON</b> and <b>OFF</b> indicating the heat mechanism is periodically being turned <b>ON</b> and <b>OFF</b> to heat the shortening gradually.</p>
2	Press the <b>SET</b> key to enter the <b>PROGRAMMING MODE</b> .	A. <i>PROGRAM</i> will appear in the display to indicate the computer is in the program mode.
3	Enter the <b>PASSWORD “3660”</b> to enter product key programming.	<p>A. <i>RECIPE</i> will appear in the display to indicate product keys may be programmed.</p> <p>B. All Product Key <b>LEDs</b> will <b>LIGHT</b>.</p>
4	Press the <b>PRODUCT KEY</b> to be programmed, i.e., <b>PK 1</b> .	<p>A. Product Key 1 <b>LED</b> will <b>LIGHT</b>, indicating it is ready to be programmed.</p> <p>B. Product Key 2 through 8 <b>LED’S</b> will be <b>OFF</b>.</p> <p>C. Prompt <i>00 STEPS</i> will appear in the display, indicating the number of cooking steps to be programmed for this product key.</p>
5	Enter the number of cooking steps to be programmed, (example <b>05</b> ); then press the <b>OK/EXIT</b> key for this number to be accepted. <b>NOTE:</b> Maximum number of steps to be accepted is <b>10</b> . <i>“TOO HIGH”</i> will appear in the display if more than <b>10</b> steps is entered.	A. Prompt <i>S1 00:00</i> will appear in the display, indicating the time for step 1 to begin is to be entered.
6	<p>A. Enter the <b>TIME STEP</b> 1 is to begin, (referenced to the end of a cook cycle); then press the <b>OK/EXIT</b> key for the time to be accepted, i.e.; <b>STEP 1 4:00</b>.</p> <p>B. Press the  Key to toggle between <b>STRAIGHT</b> or <b>FLEX</b> Timing Mode; then press the <b>OK/EXIT</b> Key for this selection to be accepted, i.e.; <b>STEP 1 FLEX</b></p> <p>C. Enter the <b>TEMPERATURE</b> for STEP 1; then press the <b>OK/EXIT</b> Key for this temperature to be accepted, i.e.; <b>STEP 1 360°F/204°C</b></p> <p><b>NOTE:</b> If <i>00:00</i> is entered, programing for this <b>PRODUCT KEY</b> is ended.</p> <p>D. Repeat Steps 6A, 6B, and 6C to program the <b>START TIME, TIMING MODE, and TEMPERATURE</b> for subsequent STEP 2, STEP 3, STEP 4, and STEP 5.</p> <p><b>NOTES:</b> 1) If <i>00:00</i> is entered for a subsequent STEP, <b>NO OTHER STEP CAN BE PROGRAMMED</b>. 2) Entry <b>MUST BE</b> between 200 and 390°F (93 to 199°C). 3) <b>TOO HIGH</b> will be displayed if entry is greater than 390°F (199°C). 4) <b>TOO LOW</b> will be displayed if entry is less than 200°F (93°C). 5) Repeated presses of the <b>OK/EXIT</b> key will scroll through time, straight/flex and temperature for each step until the last step is completed.</p>	<p>A. Prompt <i>STRAIGHT/FLEX</i> will appear in the display, indicating the Type Timing Mode is to be selected.</p> <p>B. Prompt <i>S01 000F</i> will appear in the display, indicating the Temperature in °F for STEP 1 is to be entered.</p> <p>C. Prompt <i>S2 00:00</i> will appear in the display, indicating <b>START TIME, TIMING MODE and TEMPERATURE</b> for STEP 2 is to be entered.</p> <p>D. After the <b>TEMPERATURE</b> for the last STEP (<b>STEP 5</b>) has been entered and accepted, prompt <i>ALARMS</i> will appear in the display, indicating the number of alarms desired is to be entered.</p> <p style="text-align: center;"><b>THIS FEATURE IS NOT USED!</b></p>
7	Press the <b>OK/EXIT</b> key until <i>RECIPE</i> appears in the Display, indicating another Product Key may be programmed.	A. Press the next <b>PRODUCT KEY</b> to be programmed, i.e., <b>PK2</b> .
8	Repeat steps 4 through 7 to program the next Product key.	A. When all Product Keys have been programmed and <i>RECIPE</i> appears in the display, press the <b>SET</b> key “twice” to exit the Recipe Programming Mode. <i>READY</i> will appear in the display.

## E. SHORTENING INSTALLATION

1. LIQUID SHORTENING: When using liquid shortening (cooking oil), fill the fryer with shortening even with the middle line of the “E” in the word LEVEL of the shortening level mark on the rear wall of the fryer.
2. SOLID SHORTENING:
  - a) Cut a block of solid shortening into small pieces.
  - b) Place small pieces of solid shortening EVENLY on top of the HEAT EXCHANGER TUBES or THOROUGHLY PACK these pieces of solid shortening between, below, and above the HEAT EXCHANGER TUBES. While packing solid shortening is messy and time-consuming, it is the fastest and safest way to melt solid shortening.
  - c) Ultrastat 25 equipped Fryer:
    - 1) Place the computer in the SHORTENING MELT MODE by pressing the ON/OFF key. MELT G/P will appear in the computer display to indicate the computer is in the SHORTENING MELT MODE; and the HEAT DEMANDS lamp on the computer and RED Heating indicator lamp on the fryer will cycle ON and OFF, indicating the burner is periodically being turned ON and OFF to heat the shortening gradually.
    - 2) When the heat exchanger tubes are COMPLETELY covered with LIQUID shortening and the shortening is ABOVE the MELT RELEASE TEMPERATURE, replace the grill in the fryer vat; then push the OK/EXIT key on the computer.
  - d) Continue adding solid shortening as follows:
    - 1) Place small pieces of solid shortening into a fry basket.
    - 2) CAREFULLY lower the basket into the fryer vat.
    - 3) GENTLY turn the basket to allow these pieces of solid shortening to float away.
    - 4) Repeat the above steps until liquid shortening is even with the middle line of the “E” in the word LEVEL of the shortening level mark on the rear wall of the fryer vat.

**WARNING!!! TO AVOID INJURY**

- I DO NOT MOVE A FRYER FILLED WITH HOT LIQUID.**
- II DO NOT GO NEAR THE AREA DIRECTLY OVER THE FLUE OUTLET WHEN THE FRYER'S MAIN BURNERS ARE OPERATING.**
- III ALWAYS WEAR OIL-PROOF, INSULATED GLOVES WHEN WORKING WITH A FRYER FILLED WITH HOT OIL.**
- IV ALWAYS DRAIN HOT OIL INTO A METAL TUB, POT OR CAN ... HOT OIL CAN MELT PLASTIC**

F. STARTUP AND COOKING

1. ULTRASTAT 25 START-UP - Safely startup a 14" (356 mm) gas fryer equipped with an Ultrastat 25 Cooking computer according to Section G of this section:
2. COOKING – Most products should be cooked with a shortening temperature about 360°F (182°C); however, each product should be cooked at the LOWEST temperature that produces the highest quality product while obtaining maximum usage of the shortening.
  - I DO USE A HIGH QUALITY SHORTENING TO ACHIEVE A CONSISTENT QUALITY PRODUCT AND LONG TERM SAVINGS
  - II DO NOT SALT PRODUCTS OVER THE FRYER AS SALT QUICKLY DETERIORATES THE SHORTENING AND FLAVORS OTHER PRODUCTS COOKED IN THE SAME SHORTENING
  - III DO FILTER SHORTENING ONCE A DAY AND BOIL-OUT THE FRYER EVERY 7 DAYS ACCORDING TO COMPANY POLICY.
  - IV DO NOT OPEN THE DRAIN VALVE WHILE GAS OR ELECTRICAL POWER TO THE FRYER IS ON. TO DO SO MAY CAUSE A FIRE.

TECHNICAL ASSISTANCE & ORDERING INFORMATION

A. TECHNICAL ASSISTANCE - Contact an authorized service agent or the Customer Service Department, Ultrafryer Systems at 1-800-525-8130 for technical assistance.

B. ORDERING INFORMATION:

1. REPLACEMENT PARTS - Provide the following information when ordering replacement parts by phone, fax or mail:

Your company name and phone number  
Your company purchase order number  
Bill-to address  
Ship-to address  
Quantity desired  
Part number and description of the desired-item  
Your name or signature of authorized-buyer  
Phone in order to: 1-800-545-9189 Ext 5029  
FAX order to: 1-210-731-5099  
Mail order to: Ultrafryer Systems  
Order Entry Office  
P.O. Box 5369  
San Antonio, TX 78201  
E-Mail your order to: Ultrafryerservice@ultrafryer.com

2. TERMS - Net 30 days for customers on approved accounts. Past due balances will be charged 1% per month (12% per annum) until full balance is paid.

3. DAMAGES - Ultrafryer Systems is not responsible for damage occurring in transit. All deliveries must be inspected for damage to shipping containers prior to departure of the delivering carrier. Any damage must be noted on the receiving document to facilitate filing of freight claims. Carriers must be notified immediately, and freight inspections must be requested from the carrier. Ultrafryer Systems can and will gladly assist you in preparing and processing the necessary claims only if proper notification has been accomplished on the carrier delivery document. Damaged equipment and/or containers must be available for the claims inspector to inspect.

4. RETURNS - Ultrafryer Systems cannot guarantee credit for items returned without proper authorization. All returns must have prior Ultrafryer Systems Customer Service or Warranty department approval. An assigned number will be issued by the approval authority. Please print the assigned number on all returned packages and corresponding paperwork. Returned goods are subject to a 15% restocking charge. Ultrafryer Systems is not responsible for freight charges on returned goods unless authorized by Customer Service and or Warranty personnel. Ultrafryer Systems does not receive freight collect nor C.O.D. shipments.

RECOMMENDED SPARE PARTS

- A. RECOMMENDED SPARE PARTS: To minimize downtime on the gas fryer upon failure of a component part, at least one (1) of the following items should be kept as a spare part in the local area:

GAS FRYER RECOMMENDED SPARE PARTS LISTING	
<u>Description</u>	<u>PN</u>
Ignitor Spark Module	18179
24 Volt Stepdown Transformer	18180
24 Volt Combination Gas Control Valve	18227
Air Pressure Switch	18A291
Hi-Limit Switch	19B218
¼" (5mm) Compression Fitting	24247
½" (13mm) Manual Gas Valve	24326

PARTS IDENTIFICATION

A. PARTS IDENTIFICATION - Locate the part on the following sketches and note the index number i.e, 1, 2, etc; then obtain the part number and description for that index number on the page facing the sketches. Use that part number when ordering a replacement part.

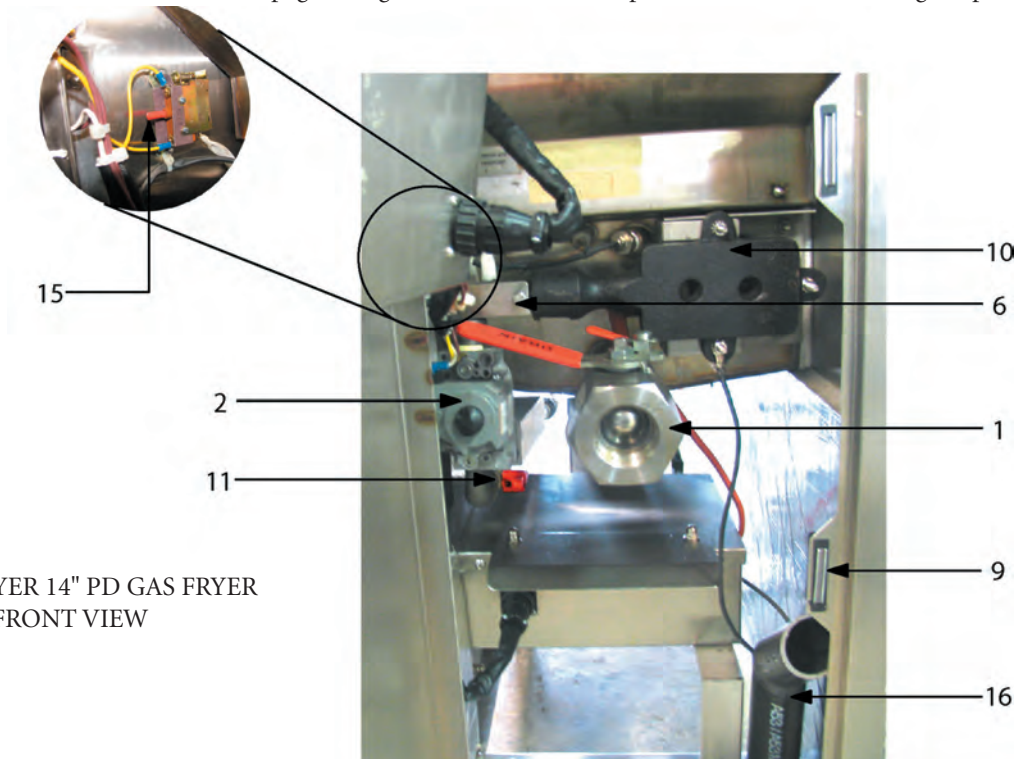

ULTRAFRYER 14" PD GAS FRYER  
FRONT VIEW

ITEM	DESCRIPTION	PN
1	1½" (38mm) Full Port Drain Ball Valve with Lock	24A204
2	Electric Gas Combination Control Valve	18227
* 3	Agitator Front Weldment Baffle	19B863
* 4	S/S Waffle Grill	19B133
* 5	Vat Joiner Strip	19B137
* 5	Vat Joiner Strip ( Large)	19B551
6	Bracket Igniter Holder	19C171
* 7	Drain Clean-Out Rod	19B159
* 8	13¼" (337 mm) x 13½" (343 mm) Vat Grill W/ Handles	19B160
9	Door Magnetic Catch	22407
10	P3 Venturi Short Side Burner	22A341
11	½" (13mm) Manual Gas Valve w/RED Handle	24326
* 12	NATURAL GAS (105k) - Orifice Plug w/#10 Drill Hole (Uses Orifice Holder PN 24A277) NATURAL GAS (95k) - Orifice Plug w/#13 Drill Hole (Uses Orifice Holder PN 24A277)	24A070 24A285
* 13	Medium Duty 4" (102mm) Front Caster w/Brake	28A010
* 14	"L" Shaped Tip Cleaning Brush	29A044
15	Hi-Limit Switch Pre-set to trip at 400°F (240°C) - NO NUTSERTS (Order ¼" (6mm) Compression Fitting PN 24247 when ordering this item)	19B218
16	Black Iron Drain Valve Extension	12B089

\* NOT SHOWN

NOTE: BUTANE and PROPANE orifice plugs are as follows:

Butane - 105k	#33 Drill Hole Size	24A287
Butane - 95k	7/64 Drill Hole Size	24A286
Propane - 105k	#31 Drill Hole Size	24A163
Propane - 95k	3.0mm Drill Hole Size	24A191

ULTRAFRYER 14" (356 mm) PD GAS FRYER  
CONTROL PANEL & ELECTRICAL BOX

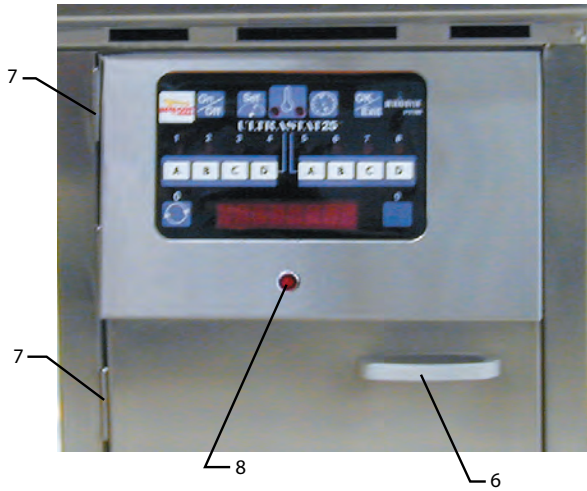

CONTROL PANEL

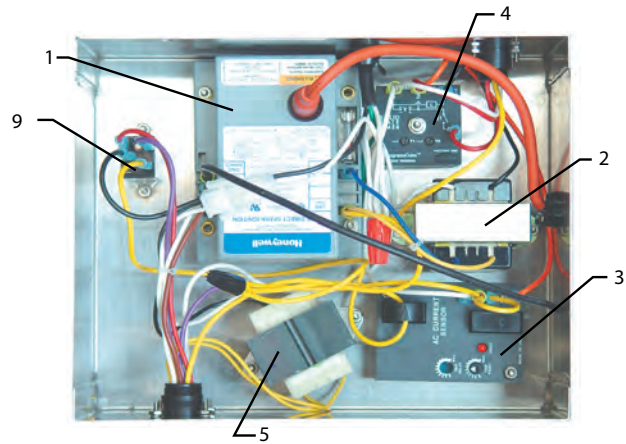

ELECTRICAL BOX ASSEMBLY  
PN 12B017

ITEM	DESCRIPTION	PN
1	Model S87B1008 Spark Ignitor Module	18179
2	120 to 24 Volt Ignition Transformer	18180
3	120 VAC Current Sensor (See Photo depicting Settings below.) NOTE 1	18A037
4	Solid State (Make/Break) Timer NOTE 2	18A072
5	120 to 24 Volt Computer Transformer	18A047
6	Chrome Door Pull	22005
7	Right Hand Door Lift Off Hinge	22640
8	120 Volt 1/3 Watt Snaplight w/RED lens	23043
9	24 Volt DC Control Relay	23A023

NOTE 1: Set current sensor to 2.5 prior to installation  
NOTE 2: Set Solid State Timer "T1" to "4" and T2" to "2"



SOLID STATE TIMER SET-  
TINGS



CURRENT SENSOR  
SETTING

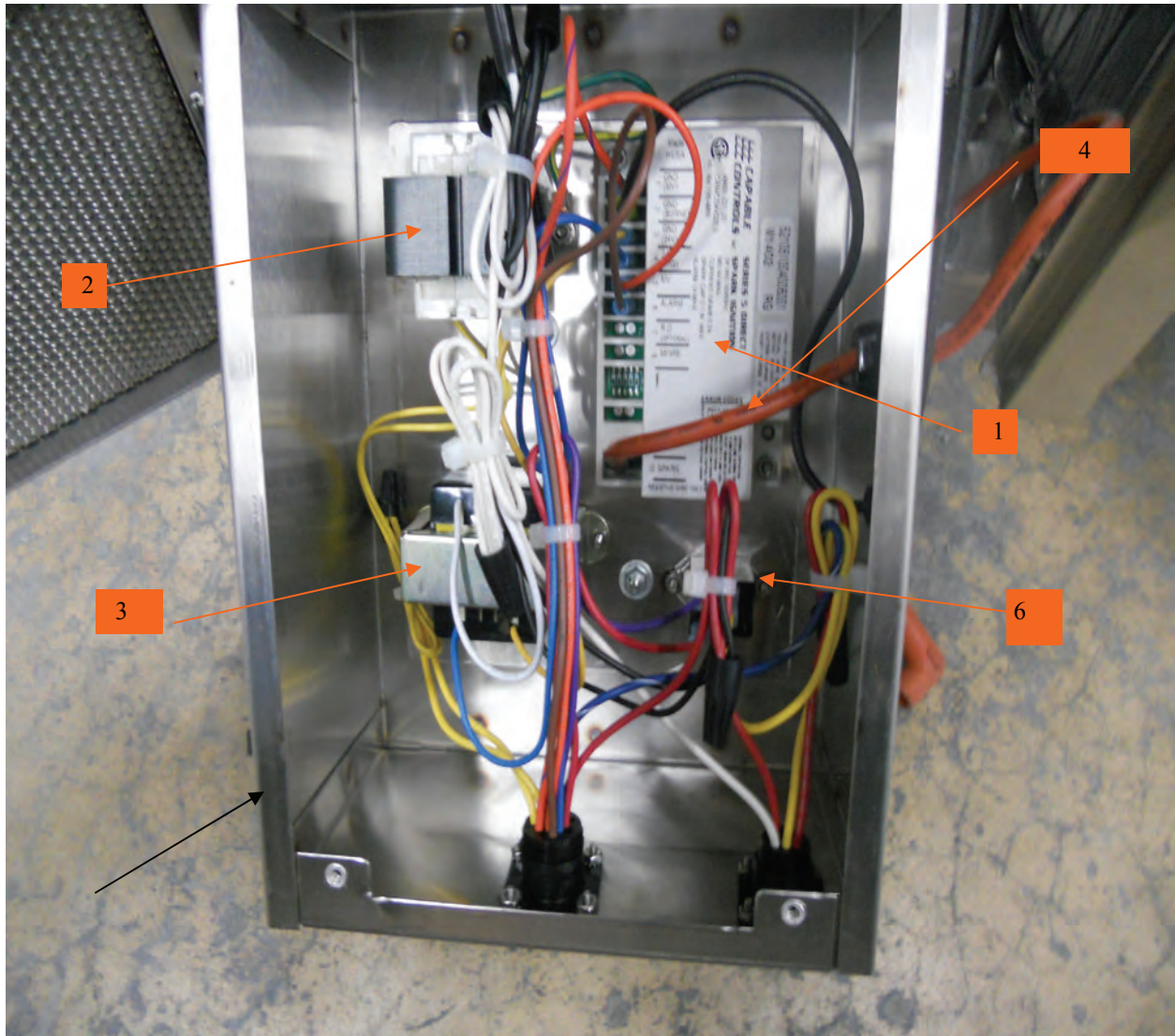

ITEM	DESCRIPTION	PART NO.
1	SPARK IGNITOR MODULE CAPABLE CONTROLS 5 TRIES W DELAY	18A362
2	TRANSFORMER, IGNITION 120V TO 24V	18180
3	TRANSFORMER, COMPUTER 120V TO 24V	18A047
4	CABLE, IGNITOR MODULE 24IN W/ 1/4"STAKE ON	22A476
5	CORD POWER	33048
6	24V DC CONTROL RELAY	23A023



7	CHROME DOOR PULL	22005
8	RIGHT HAND LIFT OFF HINGE	22640
9	120V, 1/3 WATT, SNAPLIGHT WITH RED LENS	23043

ULTRAFRYER 14" (356 mm) PD GAS FRYER  
REAR VIEW

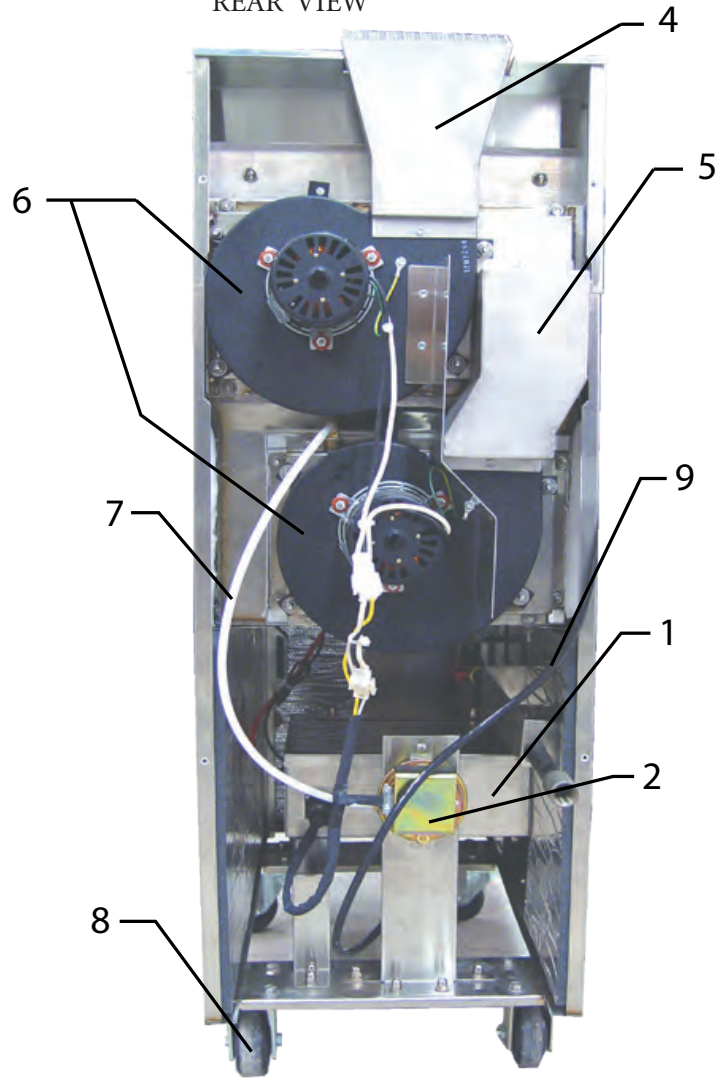

ITEM	DESCRIPTION	PN
1	Electrical Box Assembly	12B017
2	Model SMD-1204 Air Pressure Switch (NOTE)	18A291
*	Exhaust Blower Motor Plenum Gasket	19B074
4	Rectangular Flue Assembly	19B562
5	Plenum Assy Double Blower	19B115
6	Exhaust Blower Motor Kit (Order PN 19A545 F/Blower Gasket)	19B944
7	3/16" (5mm) ID, rated at 500°F (260°C) Air Pressure Tube	24A068
8	Medium Duty 3" (76mm) Caster w/out Brake	28A011
9	Type SJO 16/3 Electrical Cord w/90° Molded Plug	33048

\* Not shown

NOTE: When replacing an Air Switch, it **MUST** be adjusted with a **COLD FRYER** as discussed on the next page.

## AIR SWITCH ADJUSTMENT WITH “COLD” FRYER

To adjust the Air Switch, do the following:

1. Turn the Manual Gas Valve OFF and disconnect the Fryer’s electrical cord.
2. Attach Volt - Ohm - Meter (VOM) leads to COMMON and NORMALLY CLOSED terminal on the Air Switch and set it to read resistance.
3. Attach Pressure Meter between Blower Box and Air Switch. (Insert in the Air Pressure Tube.)
4. Cover Flue Outlet with a plate.
5. Bypass the Computer by removing the two (2) BLUE wires on the Computer’s 24 Volt DC Control Relay; then place a JUMPER on these terminal wires.
6. Connect the fryer’s electrical plug to a receptacle. The Fryer will turn ON.
7. Adjust the plate over the flue outlet until the pressure meter reads 1.3 PSI .
8. Adjust the set screw on the AIR SWITCH so the Volt - Ohm - Meter (VOM) reads ABOVE and BELOW “ZERO” continuity several times; the set it to read “ZERO”.
9. Place LOCKTITE on the Air Switch Set Screw.
10. Remove the Fryer’s electrical plug from the receptacle; remove the JUMPER wire from the Control Relay BLUE wires and reconnect them to the Relay Terminals. Remove the VOM, the Pressure Meter and the plate over the flue.
11. Connect the Fryer’s electrical plug to the receptacle, turn the gas to the Fryer ON and resume normal operations.

WIRING DIAGRAM

WIRING DIAGRAM - Since minor wiring changes may occur in the future, use the diagram posted to the fryer for circuit tracing and/or trouble-shooting a fryer.

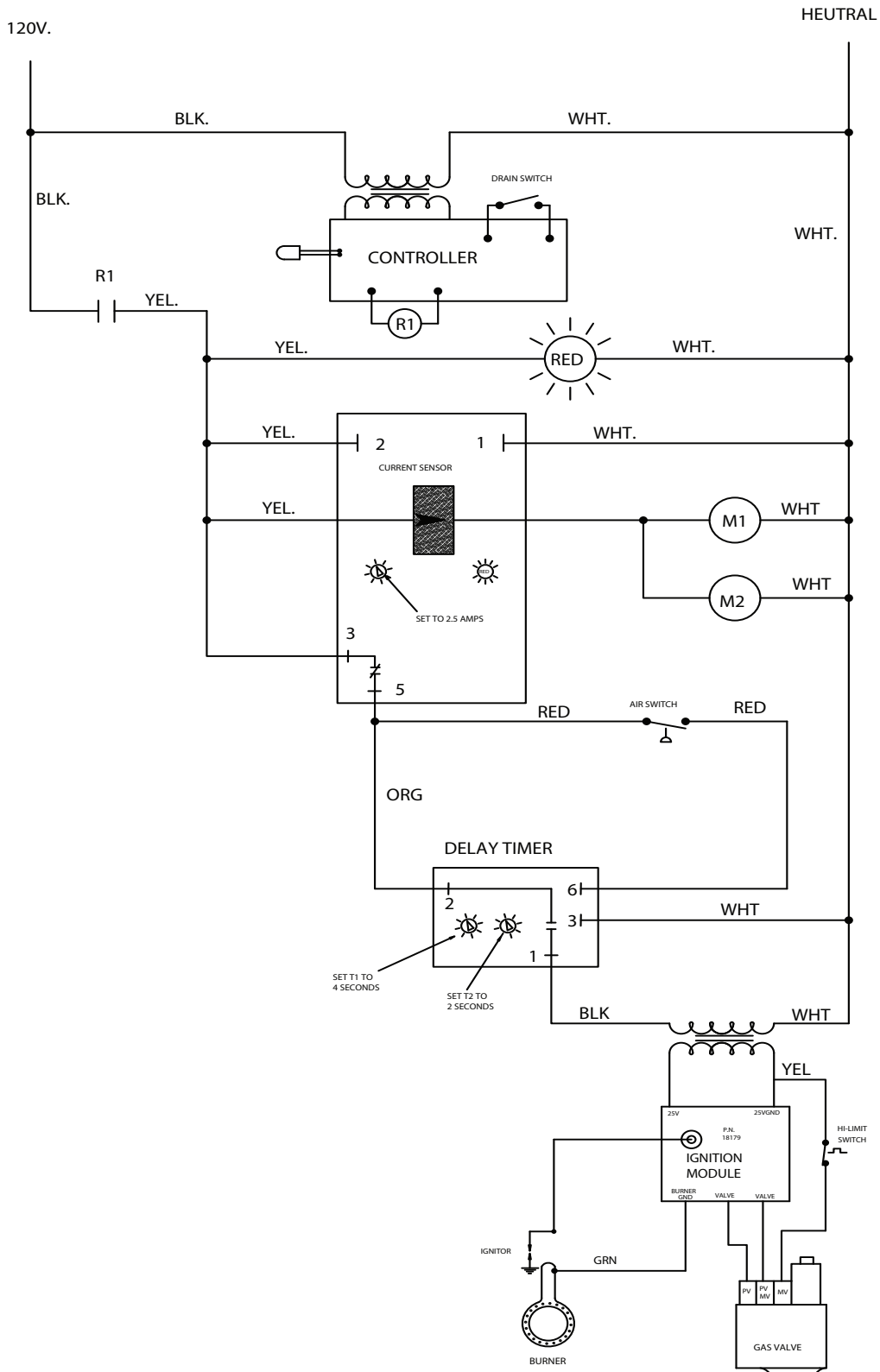

14" (356 mm) PD GAS FRYER W/COMPUTER  
WIRING DIAGRAM



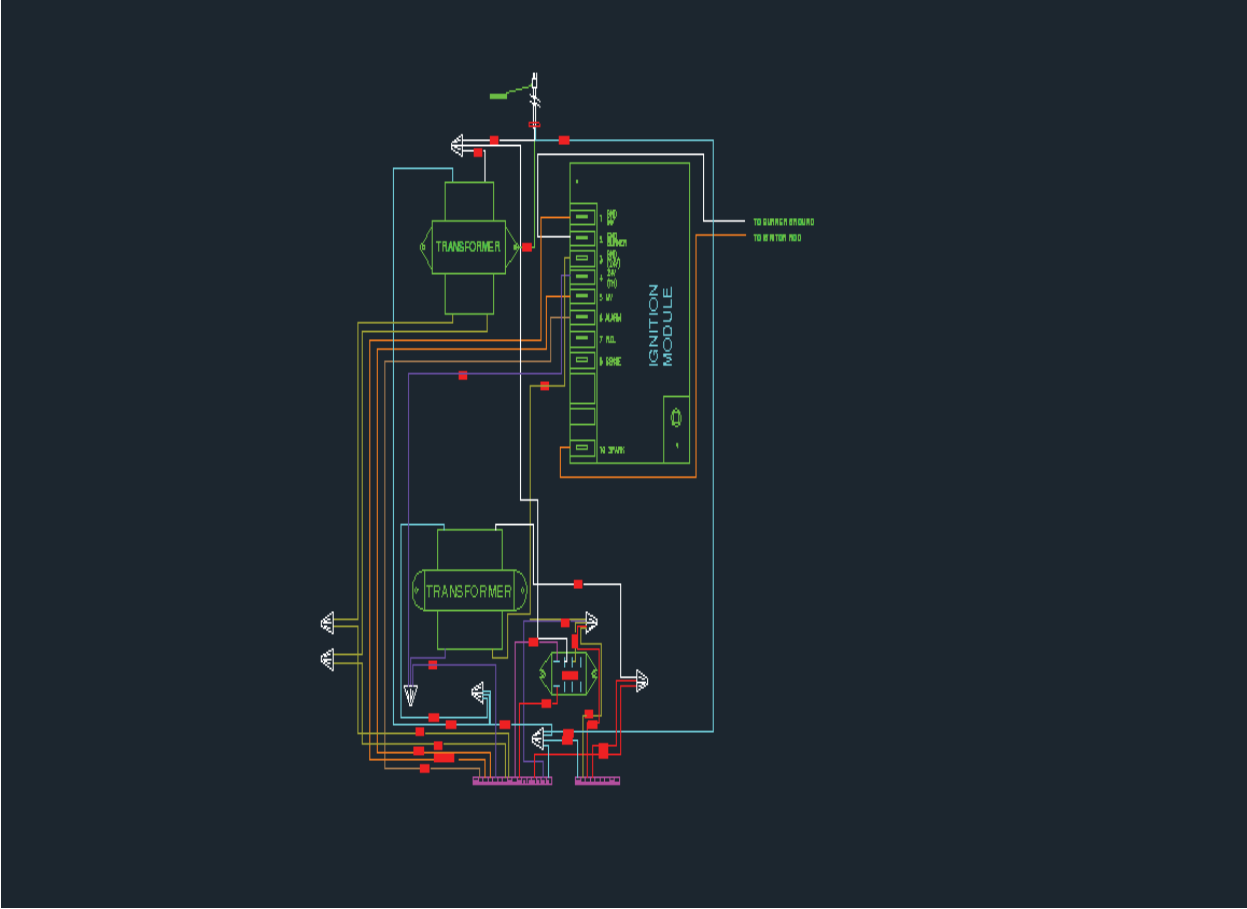

THIS PAGE INTENTIONALLY BLANK