



**ULTRAFRYER GAS FRYER
18" MODEL PAR-3-HE WITH HARD DOCK FILTRATION
OPERATING INSTRUCTIONS**



WARNING!!! TO ASSURE PRODUCING A QUALITY PRODUCT WHILE PROLONGING THE LIFE EXPECTANCY OF THE FRYER, ENSURE FILTERING, BOIL-OUT AND CLEANING INSTRUCTIONS ARE STRICTLY ADHERED TO.

302 Spencer Lane • P.O. Box 5369

San Antonio, Texas 78201

(800) 525-8130 • (210) 731-5000 • Fax: (210) 731-5099

www.ultrafryer.com

PREFACE

This Manual was written and published by the Engineering Department, Ultrafryer Systems for use by personnel who will operate a 18" Model Par-3-HE Gas Fryer equipped with an Hard Dock Filtration System.

**ENGINEERING DEPARTMENT
ULTRAFRYER SYSTEMS
302 SPENCER LANE
SAN ANTONIO, TX 78201**

TABLE OF CONTENTS

GENERAL INFORMATION	PAGE
Warranty	2
Safety	3
Description / Specifications	3
Dimensions & Operational Requirements	3
Operating Controls Location	4
Operating Controls	5
Automatic Safety Features	5
Rating Plate	5
Inlet Gas Line Sizing	6
Inlet Gas Requirements	6
PRE-INSTALLATION	
General	8
Standards	8
Air Supply & Ventilation	8
RECEIVING & INSTALLING	
Unpacking	10
Installing	10
Leveling	10
Gas Connection	11
Electrical Connection	11
Default-To-Manual-Restart (DTMR) Control	12
Optional Controls	12-13
INITIAL START-UP	
Cleaning	15
Start-Up	15
Lighting Instructions	15
Sequence Of Ignition	15
Burner Operation Test	15
Start-Up	16-17
Initial Cleaning	17
OPERATING INSTRUCTIONS	
General	19
Filtering Shortening	19
Leveling Shortening	19
Boiling Out Fryer	19
Closing / Shutdown Instructions	19

TABLE OF CONTENTS.....Continued

	PAGE
MAINTENANCE & ELECTRONIC THERMOSTAT CALIBRATION	
Maintenance	21
Electronic Thermostat Calibration.....	21
PREVENTITIVE MAINTENANCE & TROUBLESHOOTING	
Preventive Maintenance	23
Troubleshooting	23
Troubleshooting Chart.....	24
RECOMMENDED SPARE PARTS	26
CLEANING	
Daily.....	28-30
Weekly	31
FRYER OPERATION	
General.....	33
Cooking	33
Test Start-Up and Cooking	33
Default-To-Manual-Restart (DTMR) Control	33-34
DTMR Operation.....	34
Ultrastat 11 Cook Computer.....	35
Ultrastat 11 Cook Computer Operation	36
FILTER TUB ASSEMBLY & INSTALLATION	
Filter Tub Assembly	38
Filter Tub Installation.....	38
FILTERING & POLISHING SHORTENING	
Filtering Shortening	40-41
Polishing Shortening	42
SHORTENING DISPOSAL, BOIL-OUT & INSTALLATION	
General.....	45
Shortening Disposal	45-46
Boil-Out	46-47
Shortening Installation	47
TECHNICAL ASSISTANCE, ORDERING INFORMATION & PARTS IDENTIFICATION	
Technical Assistance.....	49
Ordering Information	49
Parts Identification	49-56
WIRING DIAGRAMS.....	58-60

GENERAL INFORMATION

ULTRAFRYER® LIMITED WARRANTY

Ultrafryer Systems warrants to the original purchaser of a gas or electric Ultrafryer® sold within the United States, its territories and Canada, that it will be free of defects in material and workmanship for the periods listed below:

STAINLESS STEEL FRYER VAT – Stainless Steel fryer vats are warranted for (10) ten years upon the terms hereinafter described. The (10) ten year warranty coverage applies ONLY to the Stainless Steel fryer vat and does not apply to the other components such as controls, fire boxes, gaskets, mounting hardware, or the heat shield weldment. The (10) ten year limited warranty coverage for the Stainless Steel fryer vats are as follows: (1) Vats that fail due to faulty workmanship or materials within the first twelve (12) months from the date of initial start up will be exchanged at no cost. Standard delivery ground freight will be prepaid by Ultrafryer Systems for first year failures only. The cost of labor to install the replacement vat will be covered by Ultrafryer Systems for vats, which fail within twelve (12) months from the date of initial start up. Labor for vat replacements after the first year is the responsibility of the owner.

(2) Vats that fail within the first (18) months will be exchanged at a cost not to exceed \$100.00 FOB San Antonio. (3) Vats that fail within the first (24) months will be exchanged at a cost not to exceed \$150.00 FOB San Antonio. (4) Vats that fail within the next (8) years will be exchanged at a cost not to exceed \$200.00 FOB San Antonio. (Subject to inflation adjusted in accordance with the C.P.I.). Proper credit issue for vat failures is contingent upon receipt, by Ultrafryer Systems, of the serial number identification tag for any failed vat.

ULTRAFRYER PARTS – All parts on the Ultrafryer® are covered for a period of one (1) year from the initial date of start up. This is to include computers, gas valves, switches, thermostats, etc. Ultrafryer Systems reserves the right to charge for certain parts such as computers, filter pumps and motors or any item over the amount of \$100.00 until Ultrafryer Systems receives the defective part back. After inspection, credit for the part will be issued to the purchaser provided the part is deemed defective and that defect is not the result of neglect or abuse by the user. The shortening filtration system, (hoses) are warranted for ninety (90) days from the initial date of start up.

PROCESSING WARRANTY CLAIMS – The equipment owner must promptly notify Ultrafryer Systems Warranty Department of any alleged defects as soon as they are discovered by calling 1-800-525-8130. After such notice, the Warranty Department will perform its obligation under this warranty within a commercially reasonable period of time. If alleged defects develop after normal business hours, on weekends or on holidays the owner must call Ultrafryer Systems first at the above number. This number is monitored 24 hours a day, 7 days a week. Ultrafryer Systems will notify an authorized service agent to make repairs during normal hours or after hours. Any parts that need to be shipped back to Ultrafryer Systems will be shipped back **prepaid by the customer** marked with the processing number and to the attention of the WARRANTY DEPARTMENT.

NON WARRANTY COVERAGE – This warranty does not include coverage for any consequential cost of damages including, but not limited to, any loss in store sales, spoiled food products, transportation, duty or custom cost. This warranty does not cover the Ultrafryer® exported to countries outside the United States and its territories. This warranty does not cover original installation and adjustments such as leveling, calibrations, electrical and gas connections, or problems due to faulty or contaminated gas supply. This warranty does not cover travel over 100 miles or 2 hours driving time from the location of the Ultrafryer® or overtime or holiday charges unless the Warranty Department granted prior approval. This warranty does not cover damage due to misuse, abuse, alteration or accident. This Warranty does not cover improper or unauthorized repair or installation, damage in shipment, normal maintenance items such as gaskets, hoses, and exterior finishes. **Ultrafryer Systems reserves the right to void component part warranty on any Ultrafryer® that is stored more than 6 (six) months after shipment from Ultrafryer Systems and not put into service.**

LABOR COVERAGE – The cost for labor to replace parts are covered for one (1) year after the initial start up. This warranty will include the labor involved in the six (6) month and the twelve (12) month fryer inspections recommended by the manufacturer for the first year after initial start up. **The Warranty Department must be promptly notified of any defects within the first year of operation.** The labor warranty does not include the cost to repair or clear dirty filter systems or perform any adjustments that would normally fall under the tasks associated with a proper start up and/or demonstration. **Labor is covered by Ultrafryer Systems for repairs by an AUTHORIZED service agent.** Owner is responsible for all costs associated with fryer installation and start up unless prior arrangements have been made with Ultrafryer Systems.

DISCLAIMER OF WARRANTIES

Other than as stated herein ULTRAFRYER SYSTEMS makes no warranty of any kind, express or implied, including but not limited to any warranty of merchantability of fitness for a particular purpose, including trade usage. Ultrafryer Systems sole obligation, and purchaser's sole remedy, under this warranty is repair or replacement, at the discretion of Ultrafryer Systems, of any part or component that proves to be defective in materials or workmanship. In no event shall Ultrafryer Systems be liable for consequential, incidental, or special loss or damages arising from the use of, or inability to use, the ULTRAFRYER®. This limited warranty is the only and complete statement with respect to warranties of NEW Ultrafryer® PAR-2, PAR-3 Gas and Electric ULTRAFRYERS® sold after March 1st, 2001. There are no other documents or oral statements for which Ultrafryer Systems will be responsible.

B. SAFETY

The major safety concern associated with the Ultrafryer PAR-3-HE Gas Fryer is burns from hot shortening. In order to prevent serious burns, good housekeeping habits are required. The floor in front of and the area around the fryer should be kept clean and dry. Whenever anything is placed in to a fryer vat, care should be used not to splash the hot shortening. Product should always be “**PLACED**” into the shortening, **NOT THROWN**. Safety goggles, neoprene insulated gloves and an apron must be worn while filtering or boiling-out a fryer vat. Electrical controls on all Ultrafryer Fryers operate on 120 volts single phase electrical power. No adjustments or replacement of electrical controls should ever be attempted without first disconnecting electrical power. The fryer should never be operated with wet hands or while standing in water. To do so can result in serious electrical shock or death.

C. DESCRIPTION / SPECIFICATIONS

The Ultrafryer Model PAR-3-HE Gas Fryer is constructed from 16 & 18 gauge, type 304 polished satin finish stainless steel. Most Models are equipped with a Default-To-Manual-Restart (DTMR) Control or an Ultrastat 11 Cooking Computer; however customers may request the fryer be equipped with an Ultrastat 21 or Ultrastat 25 Cooking Computer. In addition, the 18” Model PAR-3-HE is equipped with the **NEWLY** developed Hard Dock Filtration System that uses a stainless steel Filter Screen. The Customer has the option of ordering a Magnepad Filter Screen that uses a Magnesol impregnated Filter Pad in lieu of the S/S filter screen. The dimensions, specifications and gas rating of the 18” Model PAR-3-HE Gas Fryer are as follows:

D. ULTRAFRYER MODEL PAR-3-HE GAS FRYER DIMENSIONS & OPERATIONAL REQUIREMENTS

<u>SPECIFICATION ITEM</u>		<u>18” PAR-3-HE</u>
Overall Width		19 1/2” (495 mm)
Overall Depth		37 1/2” (953 mm)
Work Height		36” (914 mm)
Oil Capacity	High Level	70 Lbs (35 Liters)
Size Vat Container		18” x 18” (457 x 457 mm)
Gas Valve Pressure	Butane Gas Natural Gas Propane Gas	10.0” (254 mm) W.C. 4.0” (102 mm) W.C. 10.0” (254 mm) W.C.
Orifice Drill Size	Butane Gas Natural Gas Propane Gas	# 36 # 10 # 32
Gas Rating	Butane Gas Natural Gas Propane Gas	110,000 BTU/hr (116 MJ/hr) 110,000 BTU/hr (116 MJ/hr) 110,000 BTU/hr (116 MJ/hr)
Inlet Flow Required At STP	Butane Gas Natural Gas Propane Gas	34 FT ³ /hr (1.0 M ³ /hr) 110 FT ³ /hr (3.1 M ³ /hr) 44 FT ³ /hr (1.2 M ³ /hr)
Shipping Cube		17.9 FT ³ (.43 M ³)
Shipping Weight		265 lbs (119 kgs)
Power Input		120 Volt 6 Amp 60 Hz 1 Ø

NOTE:

TEST START-UP, OPERATIONS, COOKING, FILTERING, AND BOIL OUT PROCEDURES OF A 18” (457MM) MODEL PAR-3-HE GAS FRYER IN THIS MANUAL ARE BASED ON A DEFAULT-TO-MANUAL-RESTART (DTMR) CONTROL & ULTRASTAT 11 COOKING COMPUTER. REFER TO MANUAL PN 30A009, ULTRASTAT 21 COOKING COMPUTER OPERATOR INSTRUCTIONS; OR MANUAL PN 30A051, ULTRASTAT 25 COOKING COMPUTER OPERATION INSTRUCTIONS TO PERFORM THESE FUNCTIONS IF A PAR-3-HE FRYER WITH A COOKING COMPUTER OTHER THAN THAT LISTED IN THIS MANUAL.

E. OPERATING CONTROLS LOCATION

18" MODEL PAR-3-HE
GAS FRYER

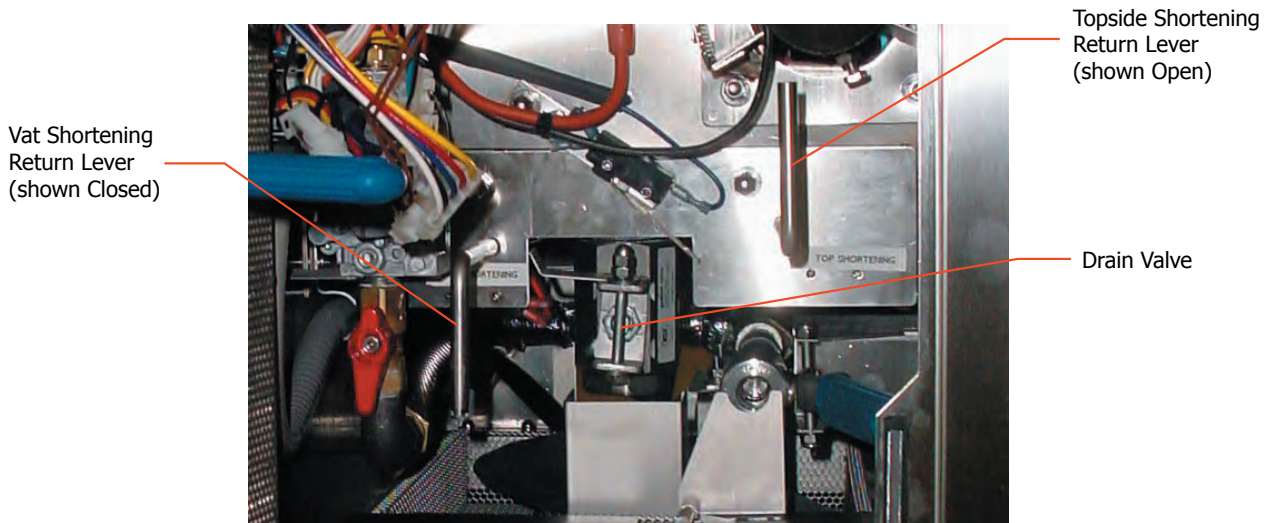
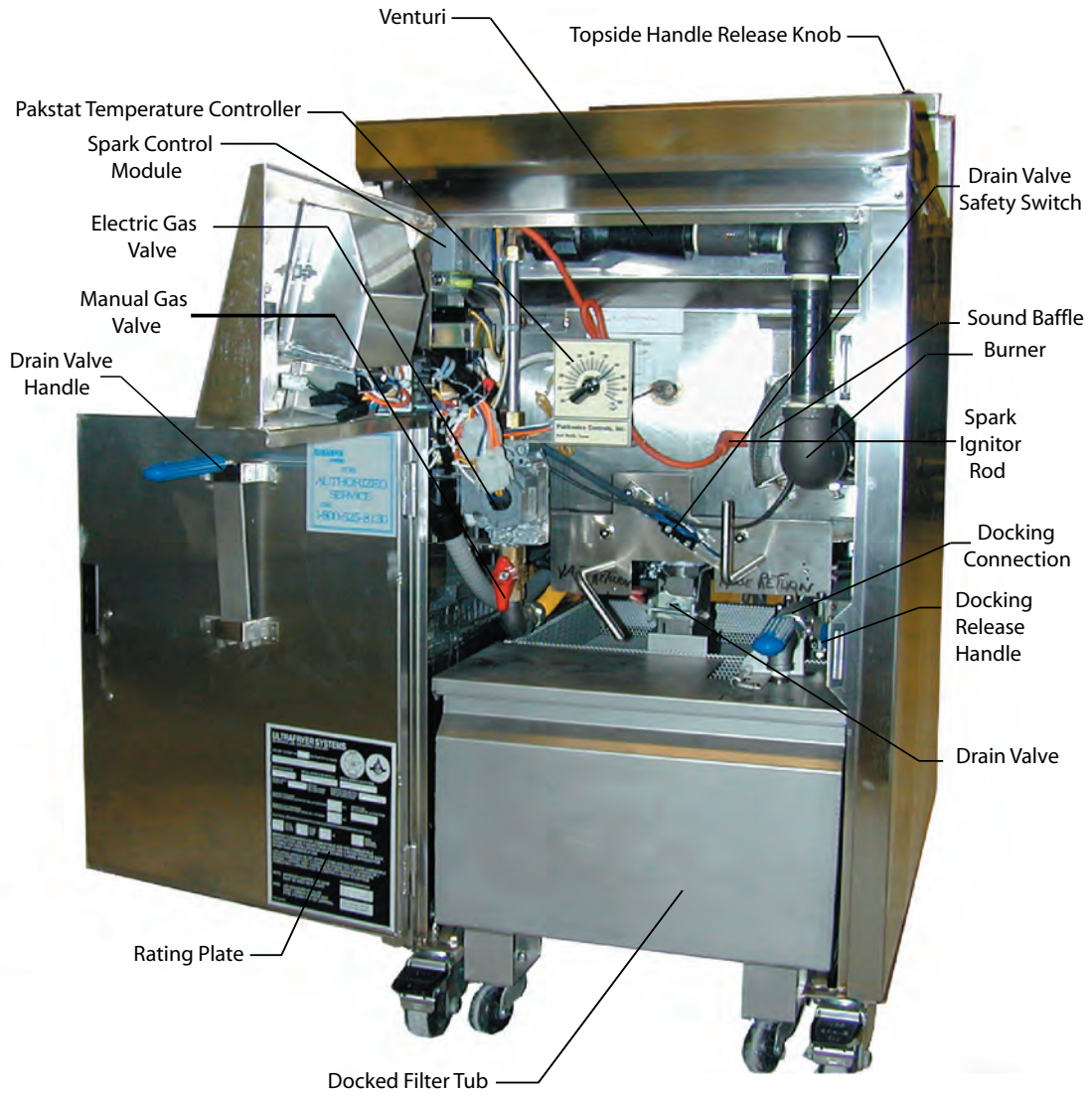

MODEL PAR-3-HE GAS FRYER

F. OPERATING CONTROLS:

The “basic” PAR-3-HE gas fryer is equipped with an Electronic Thermostat and Default-to-Manual-Restart (DTMR) control; However customers may request the fryer be equipped with an “optional” Ultrastat Cooking Computer, such as an Ultrastat 11,21 or 25 Cooking Computer shown below. When applicable, operating instructions for the Ultrastat Cooking Computer will be provided with the fryer. Operating controls on the Model PAR-3-HE gas fryer include the Toggle **ON/OFF** Switch, **AMBER** Power Indicator Lamp, **RED** Burner Indicator Lamp, and the applicable Temperature Controller. These controls are mounted on the Temperature Control Access Panel; and the Electronic Thermostat and other fryer controls are located behind the access door. The main drain valve and shortening return levers are located behind the Service Access Panel. These controls were identified in the illustrations shown on the previous page.



G. AUTOMATIC SAFETY FEATURES:

1. High limit thermostat to shut off gas to the main burners by opening a solenoid-actuated safety valve in the combination gas control valve.
2. Combination gas control valve which includes a built-in pressure regulator and manual valve.
3. Sensing circuit within the spark ignitor module to turn gas to the fryer **OFF** if a burner **FLAME OUT** occurs.
4. A Drain Valve Safety Switch and a Default-to-Off circuit in the Default-to-Manual-Restart (DTMR) Control that will **DISABLE** the fryer each time the drain valve is **OPENED**.
5. An **AIR PRESSURE** switch to open the electrical circuit to the spark ignitor and gas valve which will turn the gas to the fryer **OFF** in the event the blower motor fails.

H. RATING PLATE:

Information on this plate includes the model and serial number; BTU/HR input rating of the burners; gas manifold pressure in inches W.C. ; minimum inlet gas required, orifice size; and type of gas. This data is essential for proper identification when communicating with ULTRAFRYER SYSTEMS or requesting special parts or information. The rating plate is located on the inside of the Service Access door.

THE FRYER MUST BE CONNECTED ONLY TO THE TYPE OF GAS IDENTIFIED ON THIS RATING PLATE!

I. INLET GAS LINE SIZING:

The Table below is used to calculate the size (diameter) of the inlet gas line from the building regulator to the fryer manifold.

INLET GAS LINE REQUIREMENTS									
PIPE LENGTH	PIPE DIAMETERS (inches & (mm equivalents))								
	Maximum Allowable Flow (Shown in ft ³ /hr (M ³ /hr))								
Feet (Meters)	½" (13 mm)	¾" (19mm)	1" (25mm)	1¼" (32mm)	1½" (38mm)	2" (51mm)	2½" (64mm)	3" (76mm)	4" (102mm)
15 (4.6)	62 (1.7)	170 (4.7)	350 (9.8)	620 (17.4)	960 (26.9)	2,000 (56.0)	3,500 (98.0)	5,400 (151.2)	11,200 (313.6)
30 (9.1)	43 (1.2)	120 (3.4)	245 (6.9)	430 (12.0)	680 (19.0)	1,400 (39.2)	2,450 (68.6)	3,800 (106.4)	7,900 (221.2)
45 (13.7)	35 (1.0)	98 (2.7)	200 (5.6)	355 (9.9)	530 (14.8)	1,150 (32.2)	2,000 (56.0)	3,200 (89.6)	7,900 (182.0)
60 (18.3)	30 (0.8)	84 (2.4)	175 (4.9)	310 (8.7)	480 (13.4)	1,000 (28.0)	1,760 (49.3)	2,700 (75.6)	5,600 (156.8)
75 (22.9)	27 (0.8)	76 (2.1)	155 (4.3)	275 (7.7)	430 (12.0)	890 (24.9)	1,560 (43.7)	2,450 (68.6)	5,000 (140.0)
90 (27.4)	25 (0.7)	70 (2.0)	145 (4.1)	250 (7.0)	395 (11.1)	810 (22.7)	1,430 (40.0)	2,260 (63.3)	4,550 (127.4)
105 (32.0)	23 (0.6)	64 (1.8)	132 (3.7)	232 (6.5)	370 (10.4)	750 (21.0)	1,300 (36.4)	2,100 (58.8)	4,200 (117.6)
120 (36.6)	21 (0.6)	60 (1.7)	125 (3.5)	215 (6.0)	340 (9.5)	700 (19.6)	1,200 (33.6)	1,950 (54.6)	4,000 (112.0)
150 (45.7)	19 (0.5)	54 (1.5)	110 (3.1)	195 (5.5)	310 (8.7)	630 (17.6)	1,080 (30.2)	1,750 (49.0)	3,550 (99.4)
180 (54.9)	17 (0.5)	49 (1.4)	100 (2.8)	175 (4.9)	280 (7.8)	570 (16.0)	960 (26.9)	1,600 (44.8)	3,200 (89.6)
210 (64.0)	16 (0.4)	44 (1.2)	94 (2.6)	165 (4.6)	260 (7.3)	530 (14.8)	890 (24.9)	1,450 (40.6)	3,000 (84.0)
240 (73.2)	15 (0.4)	43 (1.2)	88 (2.5)	155 (4.3)	240 (6.7)	500 (14.0)	840 (23.5)	1,350 (37.8)	2,800 (78.4)
270 (82.3)	14 (0.4)	40 (1.1)	83 (2.3)	145 (4.1)	230 (6.4)	470 (13.2)	780 (21.8)	1,300 (36.4)	2,650 (74.2)
300 (91.4)	14 (0.4)	38 (1.1)	79 (2.2)	138 (3.9)	215 (6.0)	440 (12.3)	750 (21.0)	1,250 (35.0)	2,500 (70.0)
450 (137.2)	11 (0.3)	31 (0.9)	64 (1.8)	112 (3.1)	176 (4.9)	360 (10.1)	630 (17.6)	1,000 (28.0)	2,050 (57.4)
600 (182.9)	10 (0.3)	27 (0.8)	56 (1.6)	97 (2.7)	152 (4.3)	315 (8.8)	530 (14.8)	860 (24.1)	1,750 (49.0)

NOTE: 1) FT³/HR (M³/HR) values may vary due to heating value and specific gravity of gas supplied by local companies.
 2) To determine the inlet gas line diameter for the distance between the fryer and main gas regulator, locate the FT³/HR (M³/HR) of gas required for the fryer and pipe length and read the pipe diameter on the top row. For example: a 18" PAR-3-HE fryer operating on NATURAL GAS requires 110 FT³/HR (3.1 M³/HR) of gas at the fryer's inlet gas manifold. If the fryer bank is located 60 feet from the building gas regulator, a 1" (25mm) diameter gas line **MUST** be installed between the manifold and regulator.

J. INLET GAS REQUIREMENTS

INLET GAS REQUIREMENTS MODEL PAR-3-HE-3 GAS FRYERS								
VAT SIZE Model PAR-3-HE IN MM	GAS TYPE	GAS VALVE PRESSURE (WC)		ORIFICE HOLE SIZE	RATING		INLET GAS FLOW AT STP	
		IN	MM		BTU/HR	MJ/HR	FT ³ /HR	M ³ /HR
18" (457)	Butane	10.0	(254)	#36	110,000	(116)	34	(1.0)
	Natural	4.0	(102)	#16	110,000	(116)	110	(3.1)
	Propane	10.0	(254)	#32	110,000	(116)	44	(1.2)

NOTE: The flexible gas line used to connect the gas manifold to the building gas supply line must rated for the BTU/Hr (MJ/Hr) for the Fryer.
 For example: the BTU/Hr (MJ/Hr) rating for a PAR-3-HE fryer is 110,000 BTU/Hr (116 MJ/Hr) and therefore would require a ¾" diameter gas line.

The Flexible Gas Line used to connect the gas manifold to the building gas supply line must be rated for the BTU/Hr (MJ/Hr) designated for the Fryer. Flexible gas lines and their ratings stocked by Ultrafryer Systems are listed below:

FLEXIBLE GAS LINES STOCKED BY ULTRAFRYER SYSTEMS		
NUMBER	DESCRIPTION	RATING BTU/HR (MJ/HR)
24-322	¾" (19mm) Diameter Flexible Gas Line (w/quick connect couplings) 48" (1219mm) long. Connect-It SSGC75-48-UCQ	225,000 (238)
24-323	1" (25mm) Diameter Flexible Gas Line (w/quick connect couplings) 48" (1219mm) long. Connect-It SSGC100-48-UCQ	435,000 (459)
24-456	1¼" (32mm) Diameter Flexible Gas Line (w/quick connect couplings) 48" (1219mm) long. Connect-It SSGC125-48-UCQ	875,000 (924)

PRE-INSTALLATION

PRE-INSTALLATION: Safe and satisfactory operation of a Model PAR-3-HE gas fryer depends on its proper installation. Installation must conform to local codes or, in the absence of local codes, with the current National Fuel Gas Code ANSI Z223.1 (latest edition). In Canada, gas installation shall be in accordance with the current CAN/CGA B 149.1 and .2 installation codes and/or local codes.

A. GENERAL: Each Model PAR-3-HE fryer should be installed as follows:

1. Placed beneath a properly designed exhaust hood
2. Installed by a licensed plumber.
3. Connected to the type gas for which the unit was fabricated as shown on the rating plate.
4. Connected to the proper size pressure regulator installed in the gas supply line and adjusted to the proper manifold pressure.
5. Connected to the main gas supply line with the proper size supply line.
6. Restrained by use of a restraining device to avoid splashing of hot liquid and to assure tension cannot be placed on the flexible gas line or fittings.**CLEARANCES:** The appliance must be kept free and clear of all combustibles. The minimum clearance from combustible and non-combustible construction is 6" (152 mm) from the sides, and 6" (152 mm) from rear. The fryer may be installed on combustible floors.

NOTE: Adequate clearances must be provided for servicing and proper operation.

B. STANDARDS: Installation must be planned in accordance with all applicable state and local codes, taking into account the following standards:

1. The fryer and its individual shut-off valve must be disconnected from the gas supply piping system during any pressure testing of that system at pressures in excess of ½ psig (3.45kPA). In Canada, gas installation shall be in accordance with the current CAN/CGA B 149.1 and .2 installation codes and/or local codes.
2. The fryer must be isolated from the gas supply piping system by closing its individual manual shut-off valve during any pressure testing of the gas supply piping system at pressures equal to or less than ½ psig (3.45kPA).
3. When installed the fryer must be electrically grounded in accordance with local codes, or in the absence of local codes, in accordance with the current National Electrical code ANSI/NFPA 70 (latest edition). In Canada electrical installation must be in accordance with the current CSA C22.1 Canadian Electrical Code and/or local codes.
4. Other applicable nationally recognized installation standards such as:
 - a. National Fuel Gas Code ANSI Z223.1 (latest edition)
American Gas Association
1515 Wilson Blvd.
Arlington, VA22209
 - b. NFPA Standards #54, #94 and #221 (latest edition)
National Fire Protection Association
470 Atlantic Avenue
Boston, MA 02110
 - c. ANSI Z21.69/CAN/CGA-6.16 AND Z21.41/CAN1 6.9
5. Exhaust vent hood, when installed must conform to the current NFPA 54-1 and Canadian CAN/CGA-1.11 (latest edition)

NOTE: Local building codes will usually not permit a fryer with its open tank of hot oil to be installed immediately next to an open flame of any type, whether a broiler or an open burner or range. Check local codes before beginning installation.

C. AIR SUPPLY AND VENTILATION: The area around the appliance must be kept clear of any combustible or flammable products and avoid any obstruction to the flow of ventilation air as well as for ease of maintenance and service. **NOTHING** is to be stored in the interior of the fryer's cabinet except the filter tub assembly.

1. A means must be provided for any commercial, heavy duty-cooking appliance to exhaust combustion wastes outside of the building. It is essential that a fryer be set under a powered exhaust vent hood or that an exhaust fan be provided in the wall above the unit, as exhaust temperatures are in the vicinity of 400°F (204°C).

NOTE: Strong exhaust fans in a hood or in the overall air conditioning system can produce slight air drafts in the room, which can interfere with burner performance and be hard to diagnose. Air movement should be checked during installation and if burner problems persist, make-up air openings or baffles may have to be provided in the room.

2. Exhaust temperature, in addition to the open tank of hot oil, make the storage of anything on shelving over or behind the fryer unsafe.
3. Filters and drip troughs should be part of any industrial hood, but consult local codes before constructing and installing any hood.
4. Provisions must be made for an adequate supply of fresh air and adequate clearance must be maintained for air openings into the combustion chamber.

RECEIVING & INSTALLING

RECEIVING & INSTALLING THE FRYER

- A. **UNPACKING:** Check that the container is upright. Use an outward prying motion – **DO NOT USE A HAMMER** - to remove the carton. Check the fryer for visible damage; if such damage has occurred do not refuse shipment, but contact the carrier and file the appropriate freight claims.
- B. **INSTALLING:** Roll the assembled fryer into the building, to it's operating location.

WARNING: IMPROPER INSTALLATION, ADJUSTMENT, ALTERATION, SERVICE OR MAINTENANCE CAN CAUSE PROPERTY DAMAGE, INJURY OR DEATH. READ THE INSTALLATION, OPERATING AND MAINTENANCE INSTRUCTIONS THOROUGHLY BEFORE INSTALLING OR SERVICING THIS EQUIPMENT.

C. LEVELING:

1. When the fryer is placed in its operating location check to be sure it is level. If not, loosen the casters and insert the appropriate number of shim plates between leg and caster plates then retighten the caster bolts.
2. If the floor is smooth and level, adjust to the high corner and measure with a spirit level. If the floor is uneven or has a decided slope, level the unit with metal shims.

NOTE: A caster may not return exactly to the same position after being moved, which may require re-leveling after each move.

3. Connect the gas manifold to the building gas supply line by means of a CSA International APPROVED flexible gas line as shown in the figure below.

NOTE: CONNECT-IT inc. $\frac{3}{4}$ " (19mm), 1" (25mm) and 1 $\frac{1}{4}$ " (32mm) flexible gas hose 4 feet long (1219mm) with a quick disconnect coupling

TYPICAL GAS CONNECTION

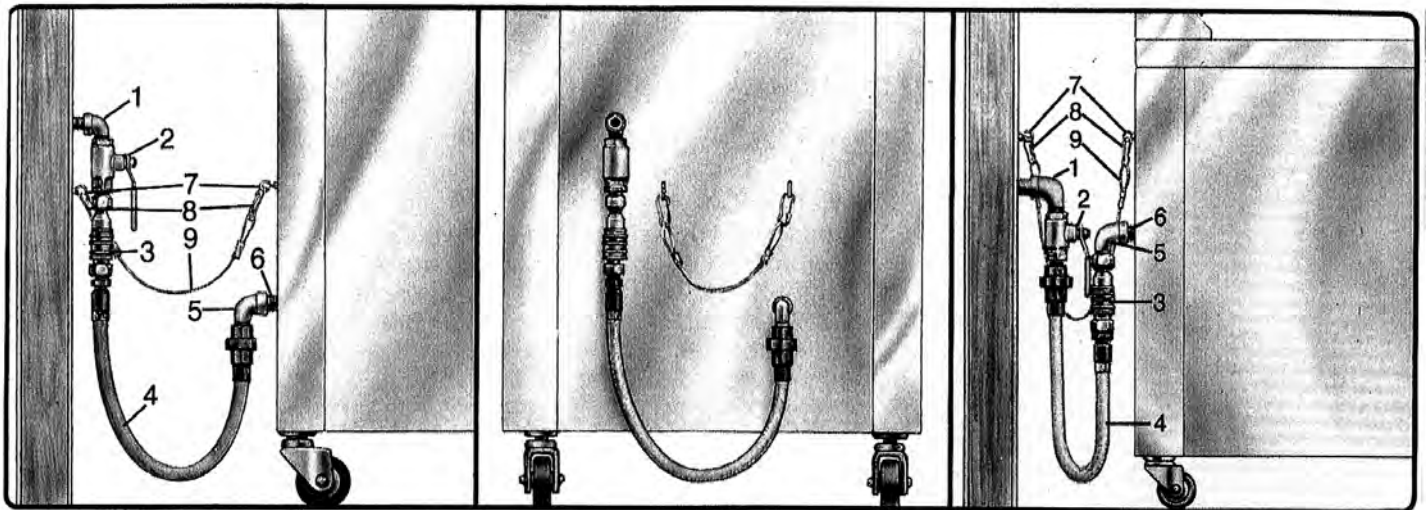

WARNING: THE RESTRAINT DEVICE (ITEM 9) MUST BE INSTALLED TO ASSURE TENSION CANNOT BE PLACED ON THE FLEXIBLE GAS LINE OR FITTING.

- | | |
|--------------------------------|------------------------------|
| 1. BUILDING GAS SERVICE LINE | 6. APPLIANCE MANIFOLD/NIPPLE |
| 2. MAIN GAS CUT-OFF VALVE | 7. EYELET FASTENERS |
| 3. CONNECT-IT QUICK-DISCONNECT | 8. SPRING HOOK |
| 4. FLEX-CON CONNECTOR | 9. RESTRAINING CHAIN |
| 5. ELBOW | |

D. GAS CONNECTION: The gas supply (service) line must be the same size or greater than the inlet line of the appliance. **THE GAS SUPPLY LINES MUST BE SIZED TO ACCOMMODATE ALL THE GAS FIRED EQUIPMENT THAT MAY BE CONNECTED TO THAT SUPPLY.** Refer to the Inlet Gas Line Sizing Table and inlet gas requirements on page 6.

NOTE: Sealant used on all pipe joints must be resistive to butane and propane gas.

1. Manual shut off valve: This supplier-installed valve must be installed in the gas service line ahead of the appliance and in a position where it can be reached quickly in the event of an emergency.
2. Pressure regulator: All commercial cooking equipment must have a pressure regulator on the incoming service line for safe and efficient operation, because service pressure may fluctuate with local demand. External regulators are not required on this fryer, as that function is performed by a combination gas control valve, however if the incoming pressure is in excess of ½ psig, a step-down regulator will be required.
3. Natural gas: Natural gas fryers require 7" (178mm) water column (W.C.) "inlet" pressure to the fryer's combination gas control valve for proper operation, when all gas units are operating simultaneously. Butane and Propane gas fryers require 14" (356mm) water column (W.C.) "inlet" pressure to the fryer's combination gas control valve for proper operation, when all gas units are operating simultaneously. This "inlet" pressure **MUST** be checked with a manometer **PRIOR** to placing the fryer in operation.

WARNING: IF THE "INLET" GAS PRESSURE AT THE FRYER'S COMBINATION GAS CONTROL VALVE "EXCEEDS" ½ lb/in² (.035 kg/cm²) OR APPROXIMATELY 14" (356 mm) W.C., AN EXTERNAL REGULATOR MAY BE NEEDED TO PREVENT DAMAGE TO THE COMBINATION GAS VALVE, AND VOIDING OF WARRANTY. FAILURE TO ADDRESS THIS COULD RESULT IN AN EXPLOSION OR A FIRE.

4. Combination gas control valve: The correct combination gas control valve and orifice is installed at the factory for **BUTANE, NATURAL** and **PROPANE** units based on each Purchase Order. This valve should be **CHECKED/ADJUSTED** by qualified service personnel using proper test equipment for the following "**OUTLET**" gas pressure **PRIOR** to start-up of a fryer. **NATURAL GAS FRYERS 4" (102mm) W.C. BUTANE/PROPANE FRYERS 10" (254mm) W.C.**
5. Rigid connections: Check any installer-supplied intake pipe(s) visually and/or blow them out with compressed air to clear dirt particles, threading chips or any other foreign matter before connecting to the service line as these particles may clog the orifice when gas pressure is applied. All connections must be tested with a soapy solution before lighting the fryer. **DO NOT USE AN OPEN FLAME TO CHECK FOR LEAKS!** Putting an open flame beside a new connection is not only dangerous, but will often miss small leaks that a soapy solution would find.
6. Flexible Couplings, Connectors: The installation is to be made with a connector that (1) complies with the **Standard for Connectors for Movable Gas Appliances, ANSI Z21.69 (CAN/CGA-6.16)**, and a quick-disconnect device that complies with the **Standard for Quick- Dis-connect Devices for Use With Gas Fuel, ANSI Z21.41 (CAN1-6.9)** (2) adequate means must be provided to limit the movement of the appliance without depending on the connector and the quick dis-connect device or its associated piping to limit the appliance movement and (3) the location(s) where the restraining means may be attached to the appliance shall be specified. **DOMESTIC CONNECTORS ARE NOT SUITABLE!!!**
7. Fryer Service: The fryer is equipped with swivel casters. To service the fryer:
 - a) Turn "OFF" gas supply at the supply source.
 - b) Disconnect the flexible gas line quick-disconnect
 - c) Disconnect restraint means and roll fryer out for rear service access.
 - d) When the fryer is re-positioned, be sure to reconnect the restraint and level the fryer.

E. ELECTRICAL CONNECTION: The **MAXIMUM** current draw per vat at Initial Start-up or during a Warm-up Cycle will be 3 Amperes at 120 Volts. When running the Filter System simultaneously allow for an additional 3 Amperes. Refer to the wiring diagram attached to the inside of the Service Access door for internal electrical connections.

- F. **DEFAULT-TO-MANUAL-RESTART (DTMR) CONTROL:** The “basic” Model PAR-3-HE gas fryer is equipped with a Default-to-Manual-Restart (DTMR) Control. This control contains a Default-to-Off electrical circuit that **DISABLES** a fryer any time the drain valve is **OPENED**, and a Default-to-Melt electrical circuit which automatically places a fryer in a shortening **MELT MODE** to gradually and **SAFELY** melt shortening each time a fryer is truned **ON** and the **START BUTTON** is drepressed on the **DTMR** control. The Default-to-Manual-Restart Control is intended to avoid “operator errors” that can result is **DRY FIRING** a fryer causing shortening to be scorched, heat exchanger damage and/or a vat fire.

DTMR CONTROL PANEL

BLUE READY TO START LAMP - When lit indicates the power on/off switch is in the **ON** position, the drain valve is **CLOSED**, and the fryer is ready to operate.

START BUTTON - When this button is momentarily depressed, it places the fryer in operation.

RED STARTED LAMP - When lit indicates the **START BUTTON** has been momentarily depressed and the fryer is operating.

AMBER MELT MODE LAMP - When lit indicates the **MELT CYCLE TIMING MODULE** in the Default-To-Melt circuit is cycling the fryer Heat System **ON** for twelve (12) seconds and **OFF** for 28 seconds to safely heat shortening.

EXIT MELT BUTTON - When this button is momentarily depressed the **MELT CYCLE TIMING MODULE** in the Default-To Melt circuit will switch to the **FULL ON** position allowing the electronic thermostat to heat shortening to its pre-set temperature.

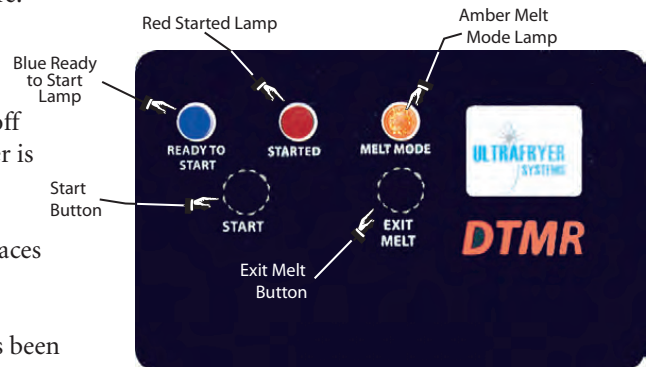

- G. **OPTIONAL CONTROLS :** The Model PAR-3-HE gas fryers may be equipped with an Ultrastat Model 11, 21, or 25 Cooking Computer as described below:

1. **ULTRASTAT 11 COOKING COMPUTER:** Some Model PAR-3-HE-3 gas fryers are equipped with an Ultrastat 11 Cooking Computer which is connected to the fryer’s electrical system to serve as its thermostat as well as providing heat control, status information and product cook timer. When the computer is in operation it will **DISABLE** the fryer if the drain valve is **OPENED**. Operation of the Ultrastat 11Cooking Computer is covered in the [Ultrastat 11 Ultrafryer Computer Operating Instrutctions PN 30A053](#) provided with Fryers equipped with that Cooking Computer.



2. **ULTRASTAT 21 COOKING COMPUTER:** The Ultrastat 21 Cooking computer is in compliance with the limits for a class B computing device pursuant to Sub-Part J of Part 15 of the FCC Rules. This cooking computer is capable of cooking up to eight (8) different products; each of which can be programmed to be cooked from one (1) to ten (10) different temperature at different times in a cook cycle. In addition, the operator can program the ULTRASTAT21 computer to cook products under “FLEX” or “STRAIGHT” timing modes. When programmed for “FLEX” time mode the computer will adjust the actual cook time taking into consideration the temperature variation due to load size, initial product temperature, product moisture content, and other factors that affect the cook cycle. Under “STRAIGHT” time mode, the product is cooked at a specified temperature for the length of time programmed without adjusting for these variations. Operation of the ULTRASTAT21 cooking computer is covered in the ULTRASTAT21 Fryer Computer Operation Instructions PN 30A009 provided with fryers equipped that computer.



3. **ULTRASTAT 25 :** The Ultrastat 25 Cooking Computer is a high performance, micro-processor based electronic controller designed for use in commercial appliance temperature and timing control applications. Utilizing a microcontroller board, membrane switch front panel with a digital LED readout, and display board, the Ultrastat 25 Cooking Computer has been customized for Ultrafryer Systems applications by the addition of up to (10) stage cooking profiles for each of the (8) product keys, exit melt feature, optional temperature setback and filtering prompt, and can be programmed to cook products under “Flex” or “Straight” timing modes. Operation of the Ultrastat 25 Cooking Computer is covered in the ULTRASTAT 25 Computer Operating Instructions PN 30A051 provided with Fryers Equipped with that computer.

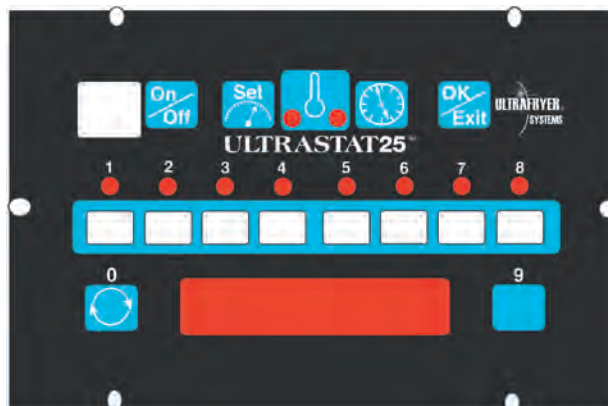

INITIAL START-UP

- A. **CLEANING:** New units are wiped clean at the factory to remove any visible signs of dirt, oil, grease, etcetera, remaining from the manufacturing process. Each fryer vessel should be thoroughly washed with hot soapy water to remove film residues, installation dust or debris; and then wiped dry before being used for food preparation.
- B. **START-UP:** The fryers are tested, adjusted and calibrated prior to being shipped; however adjustments may be necessary on installation to meet local conditions, high or low gas pressure, differences in altitudes, variations in gas characteristics and to correct possible problems caused by rough handling or vibration during shipment. Initial calibration or adjustment is the responsibility of the customer and will not be covered by the Ultrafryer Systems warranty.

NOTE: Calibration and adjustments must be performed by qualified personnel.

C. **LIGHTING INSTRUCTIONS:** Each fryer is equipped with a spark ignition system and to test this system, perform the following steps, in sequence:

1. Turn the Toggle **ON/OFF SWITCH** to the **OFF** position.
2. Fill the fryer vessel with hot or cold water to the **SHORTENING LEVEL** mark on the rear wall of the fryer vat.

CAUTION : IF THE MAIN BURNERS ARE OPERATED WITH THE VESSEL EMPTY, THE HEAT WILL CAUSE THE JOINTS OF THE FRYER VESSEL TO BE PLACED UNDER UNDO STRESS AND MAY CAUSE THE HEAT EXCHANGER VESSEL TO WARP OR BUCKLE, VOIDING WARRANTY.

3. Turn the manual gas valve located behind the fryer Service Access door to the **OFF** position and wait **FIVE (5)** minutes for any accumulated gas to disperse.
4. **ENSURE** the **MAIN** gas shut-off is in the **ON** position, **MANUAL VALVE** on the combination **GAS CONTROL VALVE** (located behind the fryer Service Access door) is in the **ON** position and the Vent Hood **EXHAUST FAN** is **ON**.
5. Turn the manual gas valve to the **ON** position.
6. Turn the **ON/OFF** switch **ON**; then place the **DTMR** or **ULTRASTAT** Cooking Computer into the **MELT MODE**.

WARNING!!! DO NOT USE A MATCH OR CANDLE TO LIGHT A FRYER... EVER!

D. **SEQUENCE OF IGNITION:** When the lighting instruction steps are performed in the sequence listed above, the following will occur:

1. Blower will come **ON** activating the air pressure switch.
2. The air pressure switch will **CLOSE** completing the electrical circuit to the transformer.
3. The transformer will supply 24 volts to the **IGNITOR MODULE** and **GAS CONTROL VALVE**, and the ignitor will **SPARK** lighting the gas in the burner.

WARNING!!! WHEN CHECKING FOR BURNER PERFORMANCE, DO NOT STAND WITH YOUR FACE CLOSE TO THE BURNER.... IT MAY LIGHT WITH A "POP" AND COULD FLASH BACK AND CAUSE FACIAL BURNS.

NOTES: 1) If the burner flame fails, it will be sensed by the **SPARK IGNITOR**, the Spark Ignitor Module will open the electrical circuit to the **GAS CONTROL VALVE** shutting off gas to the burner.

2) If the blower fails, the air pressure switch will open the electrical circuit to the **TRANSFORMER** removing electrical power from the **SPARK IGNITOR MODULE** and **GAS CONTROL VALVE** shutting off gas to the burner.

E. **BURNER OPERATION TEST:** Perform above **LIGHTING INSTRUCTIONS** and observe operation of the burners. When satisfied that the burner is operating properly, drain the fryer vessel of water and dry the vessel thoroughly; then fill the fryer vessel with shortening according to the instructions on page 45.

F. TEST START-UP :

a. **TO TEST OPERATE** an Ultrafryer Gas Fryer equipped with a Default-to-Manual-Restart (DTMR) control:

- 1) Ensure the fryer's Toggle ON/OFF Switch is in the **OFF** position.
- 2) Fill the fryer vat with hot or cold water to the middle of the “E” in the word **LEVEL** of the applicable shortening level mark on the rear of the vat.
- 3) Turn the **MANUAL** gas valve to the **OFF** position and wait **FIVE (5)** minutes for any accumulated gas to disperse.
- 4) **ENSURE** the **MAIN** gas shut-off valve is in the **ON** position, and that the Vent Hood **EXHAUST FAN** is **ON**.
- 5) Turn the **MANUAL GAS VALVE** to the **ON**

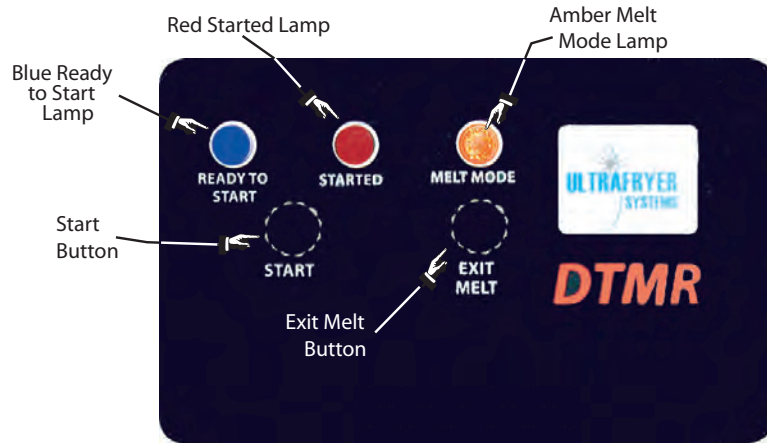

<u>ITEM</u>	<u>ACTION</u>	<u>DTMR CONDITION</u>
1	ENSURE the drain valve is in the CLOSED position and that water is at the proper level; then turn the Toggle ON/OFF switch to the ON position.	A. AMBER power lamp will LIGHT . B. BLUE READY TO START lamp will LIGHT .

CAUTION: PRIOR TO PROCEEDING TO STEP 2 VISUALLY CHECK THAT THE HEAT MECHANISM IS COVERED WITH AT LEAST 2” (51 mm) OF WATER.

2	Depress, then release the momentary START button	A. RED STARTED lamp and AMBER MELT MODE lamp will light. B. BLUE READY TO START lamp will turn OFF . C. A MELT CYCLE TIMING MODULE in the Default-To-Melt electrical circuit will begin cycling the fryer heat mechanism ON for ten (12) seconds and OFF for 28 seconds to safely heat the water.
---	---	--

CAUTION: PRIOR TO PROCEEDING TO STEP 3, VISUALLY CHECK THAT THE WATER COMPLETELY COVERS THE HEAT MECHANISM.

3	When heated and water is above the heat tubes; Depress, then release the momentary EXIT MELT button.	A. AMBER MELT MODE lamp will turn OFF and the RED STARTED lamp will remain lit. B. The MELT CYCLE TIMING MODULE in the Default-To-Melt circuit will switch to the FULL ON position, allowing the Electronic Thermostat to heat water.
4	When the water begins to boil, turn the fryer OFF , and after the water has COOLED drain the water into a floor drain.	

- b. **TO TEST OPERATE** a Ultrafryer Gas Fryer equipped with an Ultrastat 11 Cooking Computer:
- 1) Ensure the fryer's Toggle ON/OFF Switch is in the **OFF** position.
 - 2) Fill the fryer vat with hot or cold water to the middle of the "E" in the word **LEVEL** of the shortening level mark on the rear of the vat.
 - 3) Turn the **MANUAL** gas valve to the **OFF** position and wait **FIVE (5)** minutes for any accumulated gas to disperse.
 - 4) **ENSURE** the **MAIN** gas shut-off valve is in the **ON** position, and that the Vent Hood **EXHAUST FAN** is **ON**.
 - 5) Turn the **MANUAL GAS VALVE** to the **ON** position.
 - 6) Perform the following steps, in the order listed:

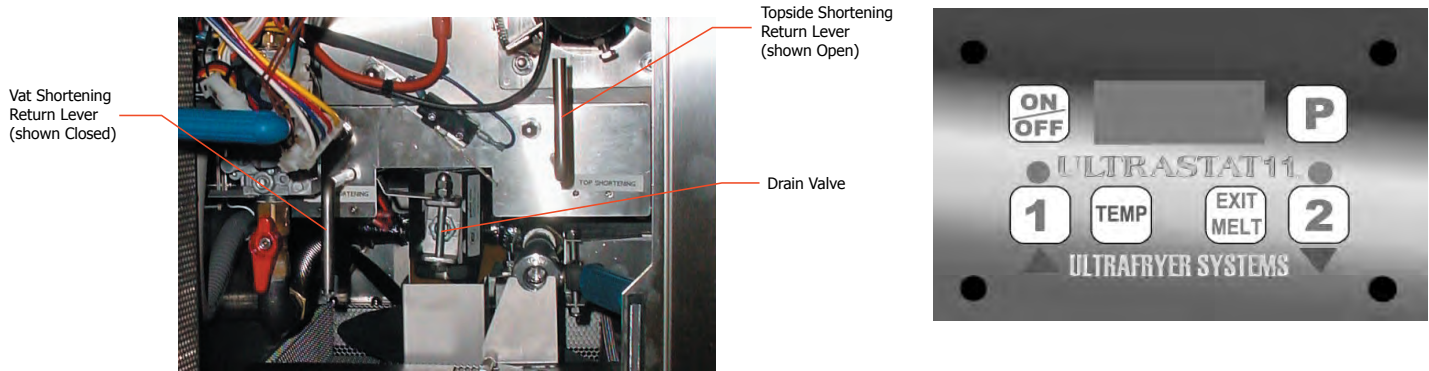

STEP	ACTION	RESPONSE
1	ENSURE the drain valve is in the closed position and that water is at the proper level; then turn the Toggle ON/OFF switch to the ON position and turn the Ultrastat 11 Cooking Computer ON by depressing the ON/OFF key.	A. The AMBER power lamp beside the fryer Toggle ON/OFF switch will LIGHT . B. CYP will appear in the Ultrastat 11 Computer display to indicate it is in the PURGE MELT MODE . C. The Computer will begin cycling the gas burner ON and OFF .
CAUTION: PRIOR TO PROCEEDING TO STEP 2, VISUALLY CHECK THAT THE HEAT EXCHANGERS TUBES ARE COVERED BY AT LEAST 2" (51 mm) OF WATER.		
2	When the water begins to BOIL , depress the EXIT MELT key.	HEAT will appear in the computer display to indicate it is in the FULL ON mode.
3	Depress the TEMP key ONCE .	The ACTUAL water temperature will be shown in the computer display

4	Turn the Ultrastat 11 OFF by depressing and holding the ON/OFF key for 3 SECONDS , then turn the fryer TOGGLE ON/OFF switch to the OFF position	The AMBER POWER lamp beside the fryer TOGGLE ON/OFF switch will turn OFF .
5	After the water in the vat and metal surfaces of the fryer has COOLED , drain the water into a floor drain.	

c. **TO TEST OPERATE** a Ultrafryer Gas Fryer equipped with an Ultrastat 21 Cooking Computer, use the procedures contained in the Ultrastat 21 Gas Fryer Computer Operation Instructions PN 30A009, provided with the fryer.

d. **TO TEST OPERATE** a Ultrafryer Gas Fryer equipped with an Ultrastat 25 Cooking Computer, use the procedures contained in the Ultrastat 25 Gas Fryer Computer Operation Instructions PN 30A051, provided with the fryer.

G. **INITIAL CLEANING** - New MODEL PAR-3-HE gas fryers are wiped clean at the factory to remove any visible signs of dirt, oil, grease, etc., remaining from the manufacturing process. Each fryer and filter system should be **THOROUGHLY** washed with **HOT** sanitizer solution to remove film residues, installation dust or debris and then wiped dry prior to placing the fryer in operation.

OPERATING INSTRUCTIONS

OPERATING INSTRUCTIONS: The Model PAR-3-HE gas fryer is equipped with a shortening filter system which is to be operated and cleaned according to the operating section of this manual.

A GENERAL:

1. **SHORTENING:** Use a high quality shortening to achieve a consistent quality product as well as a long term savings.
2. **SHORTENING TEMPERATURE:** Most products should be cooked with a shortening temperature about 350°F (177°C); however, each product should be cooked at the **LOWEST** temperature that produces a high quality product while obtaining maximum usage of the shortening.
3. **SALTING:** Products should not be salted over the fryer vessel as salt quickly deteriorates the shortening and flavors other products cooked in the same shortening.
4. **POWER FAILURES:** The Model PAR-3-HE fryer cannot be operated during power failures. **DO NOT** attempt to manually operate the fryer.
5. **PUMP MOTOR:** The filter pump motor is protected by a motor thermal overload switch.

CAUTION: ENSURE THE WASH DOWN HOSE IS NOT CONNECTED TO A FRYER PRIOR TO RESETTING A THERMAL OVERLOAD SWITCH.

B FILTERING SHORTENING: The fryer must be filtered at least twice a day (once after the lunch rush and again after the dinner rush). Place the recommended amount of filter agent in the shortening as prescribed by the chemical supplier and follow instructions for filtering shortening provided in the operating section, page 40 of this manual.

C LEVELING SHORTENING: After filtering, the shortening level must be checked and fresh shortening added when necessary.

1. The shortening in the vat should reach to the middle line of the “E” in the word LEVEL of the shortening level mark on the rear wall of the fryer.
2. If shortening is needed, use the filter scraper to cut off a small block of solid shortening.
3. Place the small block of shortening into a fry basket, lower the basket into the shortening; then turn the basket to allow the block to float freely.
4. Repeat the above steps until the shortening in the vat is at the proper level.

D BOILING OUT FRYER: The fryer should be **BOILED OUT** every **7 DAYS** to remove carbon buildup and other encrusted materials. Add the amount of boil out compound to the fryer as prescribed in the cleaning manual provided by the chemical supplier and follow instructions for boiling out a fryer in the operating section of this manual.

E CLOSING / SHUTDOWN INSTRUCTIONS:

1. **CLOSING:** When closing at night; filter the shortening in the fryer, **THOROUGHLY** drain all filter lines and cover the fryer vessel. Turn the **ON/OFF** Switch on the fryer **OFF** and turn the Manual Gas Valve **OFF**.
2. **SHUTDOWN OR PROLONGED POWER FAILURE:**
 - a. Shutdown: Perform the following whenever a fryer is being shutdown for an extended period of time:
 - 1) Drain and discard the shortening.
 - 2) **THOROUGHLY** clean the fryer vat.
 - 3) Turn the **ON/OFF** Switch to the **OFF** position, disconnect the 120-volt power cord and turn applicable Circuit Breakers **OFF**.
 - 4) Turn the Manual Gas Valve **OFF**.
 - b. Prolonged power failure: The Model PAR-3-HE fryer cannot be operated during power failures. **DO NOT** attempt to bypass safety controls and manually start the fryer.

MAINTENANCE & ELECTRONIC THERMOSTAT CALIBRATION

A. MAINTENANCE - If the Model PAR-3-HE gas fryer is equipped with an Ultrastat 11, 21, or 25 Cooking Computer **NO** maintenance is required on the Temperature Sensing Probe. However, if the fryer is equipped with a Default-to-Manual-Restart (DTMR) Control, the Electronic Thermostat may need to be adjusted or calibrated according to the following procedure:

B. ELECTRONIC THERMOSTAT CALIBRATION - The Electronic Thermostat in all fryer configurations are equipped with a Dial and Knob and should be checked and calibrated when necessary as follows:

1. **ENSURE** electrical power and, if applicable, gas to the fryer has been turned **OFF**.
2. **CAREFULLY** drain sufficient shortening from the fryer to **LOWER** the shortening about 4" (102 mm) beneath the Electronic Thermostat sensing probe.
3. After the sensing probe has **COOLED**, loop the Sensing Element of an **ACCURATE** digital test thermometer around the thermostat sensing probe; then connect the probe to the thermometer.
4. Replace shortening drained in step 2 and **ENSURE** it is level with the shortening level mark on the rear of the vat; then turn the power and, if applicable gas to the fryer **ON**.
5. Set the **KNOB** of the Electronic Thermostat to the **CENTER** (300) of the dial and periodically **STIR** the shortening in a **COUNTER-CLOCKWISE (CCW)** direction with a long handled skimmer to pull congealed shortening **UPWARD** from the Cold Zone area.
6. When shortening has reached the preset temperature and the **RED** indicator lamp on the fryer has turned **OFF**, allow the Electronic Thermostat to cycle **ON** and **OFF** about five (5) times to stabilize the system.
7. After the shortening temperature has stabilized, record the temperature reading of the **TEST THERMOMETER** immediately after the **RED** indicator lamp and the fryer turns **OFF**.
8. **CAREFULLY** loosen the set screw on the Electronic Thermostat **KNOB** without turning the thermostat potentiometer, set the thermostat knob pointer to the temperature recorded by the test thermometer; then tighten the set screw on the thermostat knob taking care not to turn the thermostat's potentiometer.
9. Repeat steps 1 and 2 above, remove the test thermometer temperature probe from the Electronic Thermostat sensing probe; then repeat step 4 to return the fryer to normal operation.



PREVENTITIVE MAINTENANCE & TROUBLESHOOTING

- A. **PREVENTIVE MAINTENANCE:** Minimal maintenance is required on Model PAR-3-HE gas fryer because of its design and the materials used in the manufacturing process. However, some preventive maintenance and inspection must be performed periodically to prevent break downs which could curtail food sales. Any preventive maintenance or inspection should be accomplished with **CAUTION** while the fryer is in operation since **HOT** liquid shortening could cause severe burns. If service or repair is required, all gas and electric power **MUST BE TURNED OFF PRIOR TO** performing that service or repair.

PREVENTIVE MAINTENANCE SCHEDULE		
<u>INSPECTION ITEM</u>	<u>INSPECTION PRIORITY</u>	<u>INSPECTION DESCRIPTION</u>
Grease Filters	DAILY	Clean grease filters in the exhaust vent hood each evening and allow them to dry overnight.
Filter Tub	DAILY	Thoroughly clean the filter tub assembly prior to leaving the store at closing
Drain Valve & Shortening Return Levers	WEEKLY	Determine that all levers are securely attached and that they can be easily opened and closed.
Temperature Sensing Probes	WEEKLY	During Boil-Out of the fryer, inspect the temperature and high limit sensing probes for any visual damage.

WARNING: CRUMBS AND SLUDGE LEFT IN THE FILTER TUB OVERNIGHT ARE A FIRE HAZARD

B TROUBLESHOOTING

- I. **GENERAL:** The problems and possible solutions listed in the troubleshooting chart below are typical problems that are frequently encountered. **ONLY** qualified repairmen are to use the troubleshooting chart to repair this fryer. In the event a main burner mal function occurs, perform the following checks **PRIOR** to contacting a repairman:
- Ensure Gas Valves are in their proper position.
 - Check that the fryer electrical plug is connected to an electrical receptacle.
 - Ensure the applicable Circuit Breaker is in the **ON** position and that the fryer ON/OFF switch is in the **ON** position.
 - Ensure the applicable fryer control has been placed in the **FULL ON** mode.
 - Ensure the gas supply line quick-disconnect coupling is **SEATED** on the gas manifold fitting.
 - Determine that the blower is operating.

- C **TROUBLESHOOTING CHART:** Should a problem occur that cannot be corrected after performing the above CHECKS, contact an authorized repairman and/or Ultrafryer Systems Customer Service 1-800-525-8130 and provide the information acquired while performing these checks.

CAUTION: ENSURE REPAIRMEN ARE ADVISED THAT FRYER RESTRAINTS MUST BE DISCONNECTED/CONNECTED. IF A FRYER IS TO BE MOVED DURING MAINTENANCE OR REPAIR, AND THAT ELECTRICAL POWER AND GAS MUST BE TURNED OFF PRIOR TO PERFORMING ANY MAINTENANCE OR REPAIR.

TROUBLESHOOTING CHART		
ITEM	PROBLEMS	POSSIBLE SOLUTIONS
1	Main burner will not ignite. Blower is operating; but gas is not present at the burner.	<p>A. Check the Blower air pressure Switch by temporarily disconnecting the two (2) ORANGE air switch wires and connecting them together. If the IGNITOR sparks when these wires are connected, the air pressure switch is defective and it will have to be replaced.</p> <p>B. Check the following components and replace if found to be defective: Gas Control Valve Hi-Limit Switch Transformer</p>
2	Electrical power is present at the fryer, but the Blower is not operating.	A. Blower may have over-heated and shut off on thermal overload. If this situation did occur, it will correct itself when the motor cools (10-20 minutes). If this overheating problem persists, replace the blower.
3	Excessive time is required to raise the shortening to cooking temperature. Temperature recovery is slow and main burner flames are small and appear to be lethargic.	<p>A. Ensure that the MANUAL GAS VALVE is completely open.</p> <p>B. Check for an obstruction in the gas line.</p> <p>C. Check for an obstruction in the flue pipe.</p> <p>D. Check that the ORFICE PLUG has the correct drill size opening as indicated on the operational requirements on the chart shown on page 7.</p> <p>E. Check for damaged BLOWER fins.</p> <p>F. Use a standard water-type U-gauge Manometer to check the pressure at the gas control valve pressure tap. Proper gas pressure is indicated on the operational requirements chart shown on page 6.</p> <p>NOTE: If necessary remove the Pressure Regulator Adjustment Cover and adjust this control to the proper pressure. (Turn adjusting screw CLOCK-WISE to increase gas pressure to the burner and COUNTER CLOCKWISE to decrease gas pressure. Replace adjustment cover.)</p>
4	Shortening temperature is too high and breaks down quickly.	<p>A. Check the gas pressure as described above.</p> <p>B. Check calibration of the Electronic Thermostat with an ACCURATE digital thermometer.</p>
5	The filter pump motor fails to operate when the Vat Shortening Return / Topside Shortening Lever is placed in the OPEN position.	<p>A. Insure the filter pump micro-switch is good, then check the manual reset button on the filter pump motor.</p> <p>B. If the filter pump motor fails to operate after the reset button has been depressed, repair or replace the motor.</p>
6	Decreased shortening flow rate while filtering.	A. Check for excessive sediment on the filter screen, standpipe suction fitting or in filter tub.
7	Pump/Motor operates but does not pump shortening.	<p>A. Check for congealed shortening in the shortening system.</p> <p>B. Check for loose Standpipe / Suction Line Coupler connection.</p>

RECOMMENDED SPARE PARTS

RECOMMENDED SPARE PARTS: To minimize downtime on the Model PAR-3-HE gas fryer upon failure of a component part, at least one (1)

MODEL PAR-3-HE GAS FRYER RECOMMENDED SPARE PARTS LISTING		
<u>Description</u>	<u>Manufacturer's Part Number</u>	<u>PN</u>
Ignitor Spark Module	Honeywell S87B1008	18-179
24 Volt Stepdown Transformer	Honeywell AT40A1121	18-180
24 Volt Combination Gas Control Valve	Honeywell VR8203A-1005	18-227
SPDT Toggle ON / OFF Switch	---	18A287
Air Pressure Switch	SMD 1204	18A291
Hi-Limit Switch Model 103KM1	Stemco 103K	19A144
½" (13mm) Apollo Pump Control Valve	---	24-036
¼" (5mm) Compression Fitting	---	24-247
½" (13mm) Manual Gas Valve	Glacomini R602	24-326

CLEANING

CLEANING - Any item of equipment operates better and lasts longer when it is kept clean and properly maintained. The Model PAR-3-HE Gas Fryer is no exception. In order for this fryer to provide years of trouble-free service, it must be **CLEANED** and **MAINTAINED** according to instructions herein and at the intervals listed below:

WARNING!!! TO ASSURE PRODUCING A QUALITY PRODUCT WHILE PROLONGING THE LIFE EXPECTANCY OF THE FRYER, ENSURE FILTERING, BOIL-OUT AND CLEANING INSTRUCTIONS ARE STRICTLY ADHERED TO.

1. DAILY

- a. Clean the fryer surface periodically during operating hours with a solution of sanitizer and hot water, and at closing with stainless steel cleaner. If necessary, use a dampened 3M type 7447 RED or 7440 BROWN (heavy duty) Scotch Brite pad to remove encrusted material. **DO NOT** use steel wool, abrasive cloths, cleaners, powders or metal devices to scrape stainless steel! Scratches on stainless steel are almost impossible to remove!

CAUTION: DO NOT ALLOW ANY CLEANING SOLUTION OR WATER TO SPLASH INTO A VESSEL OF HOT COOKING OIL, AS IT WILL CONTAMINATE THE OIL AND MAY

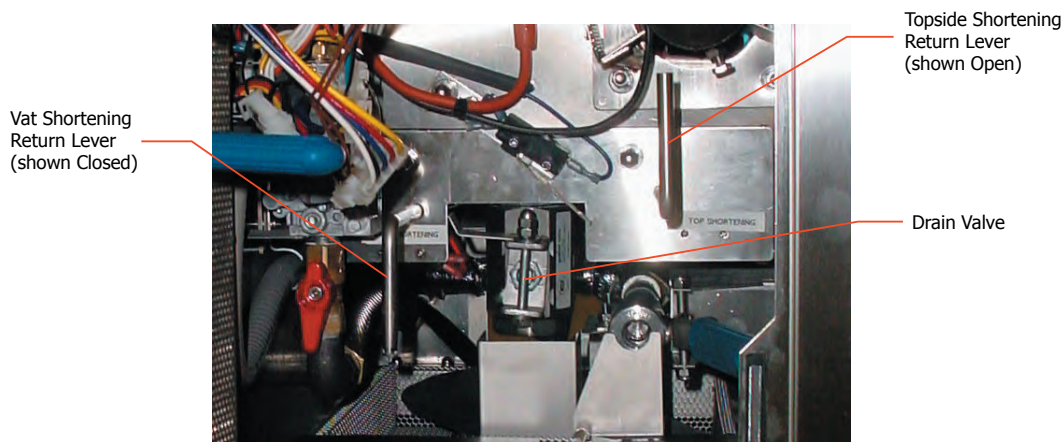

18" PAR-3-HE GAS FRYER

- b. The Filter Tub Assembly and Filter Screen should be cleaned **EACH DAY** after **FILTERING** and **AT CLOSING** and **THOROUGHLY** cleaned once each week. To remove the Filter Tub Assembly from the fryer:
 - 1) **OPEN** the Fryer's Temperature Control Access Door,
 - 2) **DEPRESS** the **DOCKING RELEASE HANDLE**, shown on page 4.
 - 3) **PULL** the Filter Tub Assembly from the fryer using the Standpipe Docking Handle Assy.
 - 4) Disassemble the Filter Tub Assembly in the following sequence:
 - a). filter tub cover
 - b). crumb catcher screen
 - c). filter screen standpipe/docking assembly; then separate the standpipe/docking assembly from the filter screen
 - 5) Clean the Filter Tub and Filter Screen as follows:

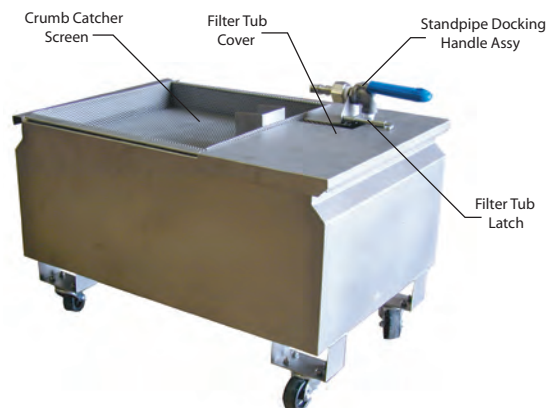

FILTER TUB OUT OF FRYER

WARNING CRUMBS AND SLUDGE LEFT IN THE FILTER TUB OVERNIGHT ARE A FIRE HAZARD

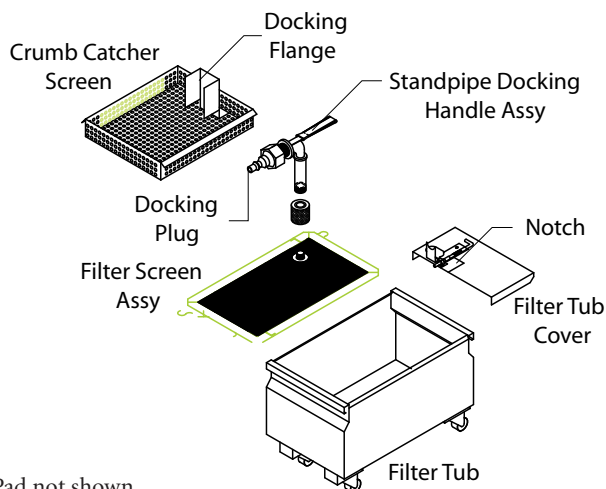
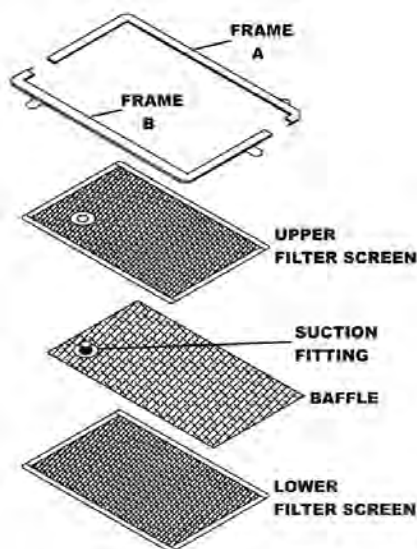

NOTE: Magnepad Filter Pad not shown

c. CLEANING THE FILTER TUB AFTER FILTERING SHORTENING

- 1.) Disassemble the Filter tub by removing the following items in the order listed; 1) **FILTER TUB COVER**, 2) **CRUMB CATCHER SCREEN**, 3) **FILTER SCREEN W/STANDPIPE/DOCKING** attached; then 4) separate the **STANDPIPE** and **DOCKING ASSEMBLY** from the Filter Screen.
- 2.) Clean the Wash Down Hose with sanitizer solution; then hang the Wash Down Hose in an upright position so shortening can drain into a container.
- 3.) Discard crumb fragments in the Crumb Catcher Pan and **THOROUGHLY** clean the pan with **HOT** water and let it air dry.
- 4.) Raise the Filter Assembly with Standpipe and Docking Assembly attached, above the Filter Tub and let any sediment or shortening drain into the tub; then separate the standpipe/docking assembly from the Filter Screen and clean the assembly with sanitizer solution and wipe it dry with a lint free cloth. **THOROUGHLY** clean the filter assembly as follows:
 - (a) “Micro-Mesh” Stainless Steel Filter Screen
 - (1) **CAREFULLY** remove any debris from the screen using a scraper.
 - (2) Grasp the **FINGER LOOP** on **FRAME A** and adjacent **FINGER LOOP** on **FRAME B**, **EVENLY** pull the frames apart; then **HINGE FRAME A** to remove it from the **FILTER SCREENS FIRST**.
 - (3) Grasp the **FINGER LOOP** on the straight side of **FRAME B**; then **HINGE** it to remove **FRAME B** from the **FILTER SCREENS**.
 - (4) Separate the **UPPER FILTER SCREEN** and **BAFFLE** from the **LOWER FILTER SCREEN**.
 - (5) **CAREFULLY** clean the two frames, screens and baffle in the 3 compartment sink with hot water and allow these items to air dry. **DO NOT USE SOAP**. If necessary the channels in each frame can be cleaned with the edge of a scotch-brite pad.
 - (6) Insert the **SUCTION FITTING** on the **BAFFLE** in the hole of the **UPPER FILTER SCREEN**; then place these items on top of the **LOWER FILTER SCREEN**.
 - (7) **ENSURE** all sides of the **FILTER SCREEN** assembly are aligned, place the **PIN** end of **FRAME A** on the **FILTER SCREENS**, place the **CHANNEL** on the frame adjacent to the **PIN** end over the **FILTER SCREENS**; then **HINGE** the frame so the edge of the **FILTER SCREENS** are inserted in the other **CHANNEL** of **FRAME A**.
 - (8) Place the **PIN** end of **FRAME B** on the **FILTER SCREENS** so the **PIN** is seated in the **CHANNEL** of **FRAME A** near the **FINGER LOOP**, place the **CHANNEL** on the frame adjacent to the **PIN** end over the edge of the **FILTER SCREENS**; then **HINGE** the frame so the edge of the **FILTER SCREENS** are inserted in the other **CHANNEL** of **FRAME B** and the **PIN** of **FRAME A** is seated in the **CHANNEL** of **FRAME B**.
 - (9) Adjust **FRAME A** and **B** so both **PINS** are properly seated in the **CHANNEL** of the opposite frame; then **CAREFULLY** connect the **KNURL KNOB** on the **STANDPIPE/DOCKING ASSEMBLY** to the **SUCTION FITTING** on the **FILTER SCREEN** assembly. **DO NOT OVERTIGHTEN!!!**
 - (b) Magnepad Envelope Filter: Magnepad Filter Assemblies **DO NOT** have to be **SCRAPED** after filtering shortening.
- 5.) Remove any sediment and shortening in the Filter Tub using a scraper; then wipe the tub dry with paper towels.
- 6.) **CAREFULLY** insert the assembled Filter Screen in the bottom of the Filter Tub; then **CAREFULLY** insert the Crumb Catcher Pan in the Filter Tub with the **DRAIN VALVE Docking Flange** over the leading edge of the pan.

- 7.) **CAREFULLY** position the **FILTER TUB COVER** on the **OPEN** end of the Filter Tub with the **SLOT** on the cover seated around the Stand-pipe Handle Docking Assembly. Then, **SECURE** the cover to the standpipe assembly by locking the latch on the cover.
- 8.) Position the **ASSEMBLED** Filter Tub in front of the **FILTER TUB GUIDES** beneath the fryer; then **CAREFULLY** and **SLOWLY** insert the Filter Tub into the fryer using Standpipe Docking Handle Assy until the **MALE** In Line Plug on the Standpipe Docking Handle Assembly seats in the **FEMALE** Bulkhead Coupling adjacent to the Drain Valve Assembly.

WARNING!!! TO ASSURE PRODUCING A QUALITY PRODUCT WHILE PROLONGING THE LIFE EXPECTANCY OF THE FRYER, ENSURE FILTERING, BOIL-OUT AND CLEANING INSTRUCTIONS ARE STRICTLY ADHERED TO.

d. CLEANING THE FILTER TUB AFTER CLOSING

1.) “Micro Mesh” Stainless Steel Filter Screen:

Repeat **DAILY** steps 1 c page 29; then, **THOROUGHLY** clean the Filter Assembly as follows:

- a) **THOROUGHLY** flush any remaining sediment from both sides of the filter screen with **HOT WATER**.
- b) Grasp the **FINGER LOOP** on **FRAME A** and adjacent **FINGER LOOP** on **FRAME B**, **EVENLY** pull the frames apart; then **HINGE FRAME A** to remove it from the **FILTER SCREENS FIRST**.
- c) Grasp the **FINGER LOOP** on the straight side of **FRAME B**; then **HINGE** it to remove **FRAME B** from the **FILTER SCREENS**.
- d) Separate the **UPPER FILTER SCREEN** and **BAFFLE** from the **LOWER FILTER SCREEN**.
- e) **CAREFULLY** clean the two frames, screens and baffle in the 3 compartment sink with hot water and allow these items to air dry. **DO NOT USE SOAP**. If necessary the channels in each frame can be cleaned with the edge of a scotchbrite pad.
- f) Insert the **SUCTION FITTING** on the **BAFFLE** in the hole of the **UPPER FILTER SCREEN**; then place these items on top of the **LOWER FILTER SCREEN**.
- g) **ENSURE** all sides of the **FILTER SCREEN** assembly are aligned, place the **PIN** end of **FRAME A** on the **FILTER SCREENS**, place the **CHANNEL** on the frame adjacent to the **PIN** end over the **FILTER SCREENS**; then **HINGE** the frame so the edge of the **FILTER SCREENS** are inserted in the other **CHANNEL** of **FRAME A**.
- h) Place the **PIN** end of **FRAME B** on the **FILTER SCREENS** so the **PIN** is seated in the **CHANNEL** of **FRAME A** near the **FINGER LOOP**, place the **CHANNEL** on the frame adjacent to the **PIN** end over the edge of the **FILTER SCREENS**; then **HINGE** the frame so the edge of the **FILTER SCREENS** are inserted in the other **CHANNEL** of **FRAME B** and the **PIN** on **FRAME B** is seated in the **CHANNEL** of **FRAME A**.
- i) Adjust **FRAME A** and **B** so other **PINS** are properly seated in the **CHANNEL** of the opposite frame; then **CAREFULLY** connect the **KNURL KNOB** and **STANDPIPE/DOCKING ASSEMBLY** to the **SUCTION FITTING** on the **FILTER SCREEN** assembly. **DO NOT OVERTIGHTEN!!!**

2.) “Magnepad” Envelope Filter:

Remove and discard the **USED** Filter Pad Envelope. **CAREFULLY** clean the Baffle Assembly and Clip/Stand-pipe assembly in a 3 compartment sink with **HOT** water and allow these items to air dry. **DO NOT USE SOAP!!** Reassemble the Magnepad Envelope Filter using a **NEW** Magnesol Impregnated Filter Pad Envelope as follows:

- a. Insert the **BAFFLE** into the **FILTER PAD ENVELOPE**, when properly inserted the **SUCTION FITTING** will protrude through the hole in the pad.
- b. Fold the **FLAP** over (in the direction of the hole) securing the Baffle inside the **FILTER PAD ENVELOPE**.
- c. **CAREFULLY** align the **CLIP & STANDPIPE ASSEMBLY** so that the clip can secure the **FLAP** and the envelope and the **STANDPIPE** will align over the **SUCTION FITTING** protruding through the envelope.
- d. Tighten the knurled **NUT** on the **STANDPIPE** to the **SUCTION FITTING** protruding through the envelope.
- e. Repeat **DAILY** steps 1 a through 1 d pages 28-30.

2. WEEKLY

- a. Perform daily cleaning steps 1a through 1c on pages 28-30.
- b. Clean the Filter Assembly as follows:
 - 1) “Micro-Mesh” stainless steel filter screen:
 - a) Disassemble the filter accordingly to DAILY steps 1 c 4 and clean the two (2) frames as described in step 1 c 4 a (5) page 29.
 - b) Place the upper and lower FILTER SCREENS in the fryer with BOIL-OUT SOLUTION for cleaning. DO NOT PLACE THE BAFFLE OR STANDPIPE IN THIS SOLUTION!!! BOIL-OUT the fryer vat according to instructions contained in the cleaning manual provided by your chemical supplier.
 - c) After the filter screens have been cleaned in the Boil-Out Solution, ENSURE they are THOROUGHLY sprayed with a solution of 1 PART vinegar to 25 PARTS of water to NEUTRALIZE the boil-out solution, then allow the screens to air dry. NOTE: any residue of boil-out solution on the filter screens could cause the rapid break-down of the shortening.
 - d) Reassemble the “Micro-Mesh stainless steel filter according to DAILY steps 1 c 4 a) (6) page 29.
 - 2) “Magnepad” Envelope Filter – Disassemble, clean, and re-assemble the “Magnepad” Filter Assembly according to DAILY cleaning steps 1 d 2) page 30.
- c. Place the CRUMB CATCHER PAN and SLUDGE CATCHER SCREEN in the fryer with the Boil-Out Solution for cleaning, and after they are cleaned, ENSURE they are sprayed with a solution of vinegar/water as described in WEEKLY above.
- d. THOROUGHLY clean the Filter Tub, Cover and Sludge Catcher Pan with HOT SANITIZER SOLUTION and allow them to air dry.
- e. Re-assemble the Filter Tub according to DAILY steps 1 c 6) through 1 c 8) pages 29 & 30.

FRYER OPERATION

A. GENERAL - The “basic” Model PAR-3-HE Gas Fryer is equipped with a Default-to-Manual-Restart (DTMR) Control, which uses an Electronic Thermostat. Some fryers are equipped with an Ultrastat 11,21 or 25 Cooking Computer that use the same Temperature Sensing Probe. In this section, the operation of the PAR-3-HE Gas Fryer will cover the Default-to-Manual-Restart (DTMR) Control and the Ultrastat 11 Cooking Control.

NOTE: Refer to Manual PN 30A009, ULTRASTAT 21 Cooking Computer Operating Instruction; or Manual PN 30A051, ULTRASTAT 25 Cooking Computer Operator Instructions for operation of a fryer with one of these controls.

B. COOKING: Most products should be cooked with a shortening temperature about 350°F (177°C); however, each product should be cooked at the **LOWEST** temperature that produces a high quality product while obtaining maximum usage of the shortening.

DO USE A HIGH QUALITY SHORTENING TO ACHIEVE A CONSISTENT QUALITY PRODUCT AND LONG TERM SAVINGS.

DO NOT SALT PRODUCTS OVER THE FRYER AS SALT QUICKLY DETERIORATES THE SHORTENING AND FLAVORS OTHER PRODUCTS COOKED IN THE SAME SHORTENING.

DO FILTER SHORTENING AFTER THE LUNCH AND DINNER RUSH AND MORE OFTEN IN A HIGH SALE VOLUME STORE; AND BOIL-OUT THE FRYER EVERY SEVEN (7) DAYS.

WARNING: WHEN ASSEMBLED, ENSURE THERE ARE NO FINGER LOOPS ON THE STANDPIPE SIDE OF THE MICRO-MESH FILTER.

C. TEST START-UP AND COOKING

1. **GENERAL:** The Default-To-Manual-Restart(DTMR) Control along with an Electronic Thermostat is connected to a fryer’s electrical system to control operation of the fryer.

a. The DTMR contains a Default-To-Off circuit that will **DISABLE** the fryer anytime the Drain Valve is **OPEN**, and a Default-To-Melt circuit that will automatically place the fryer in a **SHORTENING MELT MODE** to gradually and safely heat shortening each time the fryer’s toggle ON/OFF switch is turned **ON**.

b. **Electronic Thermostat:** The Electronic Thermostat has a temperature range from 200°F (93°C) to 400°F (204°C) and will accurately maintain a preset shortening cook temperature within 2°.



2. DEFAULT-TO-MANUAL-RESTART (DTMR) CONTROL

a. **BLUE READY TO START LAMP** - When lit indicates the fryer’s Toggle ON/OFF switch is in the **ON** position, the Drain Valve is **CLOSED** and the fryer is ready to be placed in operation.

b. **START BUTTON** - When the button is momentarily depressed, it places the fryer in operation.

c. **RED STARTED LAMP** - When lit indicates the **START BUTTON** has been depressed, placing the fryer in operation.

d. **AMBER MELT MODE LAMP** - When lit indicates the fryer is in the **MELT MODE** and that the melt cycle timing module in the DTMR Default-to-Melt circuit is turning the fryer’s heat mechanism **ON** and **OFF**, to gradually and safely heat the shortening.

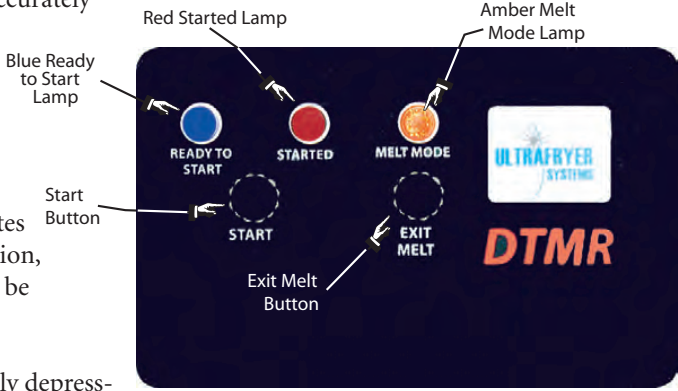

- e. **EXIT MELT BUTTON** - When this button is momentarily depressed, the melt cycle timing module in the DTMR's Default-to-Melt circuit will switch to the **FULL-ON** position allowing the Electronic Thermostat to heat shortening to its **PRE-SET** temperature.

D. DTMR OPERATION - Prior to operating the Model PAR-3-HE Gas Fryer, **ENSURE** the Filter Tub Assembly is properly installed and **DOCKED** to the fryer's Bulkhead socket and the Temperature Control Access Door is closed, the fryer vat is filled with shortening to the middle of the "E" in the word **LEVEL** of the shortening level mark on the rear wall of the vat; then:

1. Turn the Toggle ON/OFF Power Switch to the **OFF** Position.
2. Turn the **MANUAL** gas valve to the **OFF** position and wait **FIVE (5)** minutes for any accumulated gas to disperse.
3. **ENSURE** the **MAIN** gas shut-off valve is in the **ON** position, and that the **EXHAUST FAN** is **ON**.
4. Turn the **MANUAL** gas valve to the **ON** position.
5. Perform the following steps, in the order listed:

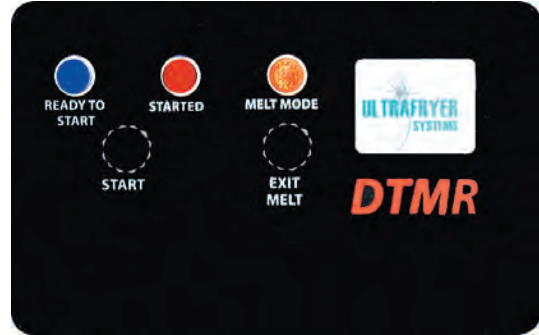

ITEM	ACTION	DTMR CONDITION
1	ENSURE the drain valve is in the CLOSED UP position and that shortening is at the proper level; then turn the Toggle ON/OFF switch to the ON position.	A. AMBER power lamp will LIGHT. B. BLUE READY TO START lamp will LIGHT.

CAUTION: PRIOR TO PROCEEDING TO STEP 2 VISUALLY CHECK THAT THE HEAT ELEMENT IS COVERED WITH AT LEAST 2" (51 mm) OF SHORTENING.

2	Depress, then release the momentary START button.	A. RED STARTED lamp and AMBER MELT MODE lamp will light. B. BLUE READY TO START lamp will turn OFF. C. The MELT CYCLE TIMING MODULE in the Default-To-Melt electrical circuit will begin cycling the fryer heat mechanism ON for twelve (12) seconds and OFF for 28 seconds to safely heat the shortening.
---	--	--

CAUTION: PRIOR TO PROCEEDING TO STEP 3, VISUALLY CHECK THAT THE SHORTENING COMPLETELY COVERS THE HEAT MECHANISM.

3	Depress, then release the momentary EXIT MELT button.	A. AMBER MELT MODE lamp will turn OFF, RED STARTED lamp will remain lit. B. The Melt Cycle Timing Module in the Default-To-Melt circuit will switch to the FULL ON position allowing the Electronic Thermostat to heat shortening to its pre-set temperature.
4	When the fryer's pre-set temperature has been reached, initiate a cook cycle.	

E. ULTRASTAT 11 COOKING COMPUTER
1. COMPUTER PANEL KEY DESCRIPTIONS



CONTROL KEY	NO.	DESCRIPTION
ON/OFF	1	To turn the Ultrastat 11 Computer ON depress the ON/OFF key ONCE
	2	To turn the Ultrastat 11 Computer OFF depress and hold the ON/OFF key for 3 SECONDS.
1 ▲	1	In OPERATING mode, used to INITIATE or CANCEL a cook cycle on the LEFT HAND timer.
	2	In programming mode, used to increase cooking time or temperature.
2 ▼	1	In OPERATING mode, used to INITIATE or CANCEL a cook cycle on the RIGHT HAND timer.
	2	In programming mode, used to decrease cooking time or temperature.
TEMP	1	Used to display ACTUAL TEMPERATURE when depressed ONCE.
	2	Used to display SETPOINT TEMPERATURE when depressed TWICE.
	3	Used to display remaining TIME when depressed THREE TIMES.
EXIT MELT	1	Used to manually exit the MELT MODE
P	1	Used to ENTER or EXIT the PROGRAMMING mode.
	2	In PROGRAMMING mode, used to cycle through program options
	3	Press and hold 3 seconds to EXIT program mode

2. ULTRASTAT 11 COOKING DISPLAY DESCRIPTIONS

DISPLAY	DESCRIPTION
300	- Time in Minutes and seconds.
360F	- Temperature in degrees Fahrenheit
182C	- Temperature in degrees Celsius.
C.Y.P	- Purge Melt Cycle.
-----	- Shortening Temperature is below 100°F (38°C) or above 392°F (200°C).
HEAT	- The Controller is in Heating Mode.
.	- Heating mechanism is ON.
drop	- The fryer is ready for cooking.
ProB	- The Temperature Probe is OPEN.
HI	- The Temperature Probe is SHORTED or shortening temperature is above the setpoint temperature.
L	- Shortening temperature is BELOW setpoint temperature.
ULOC	- Unlock Password Option.
LOC	- Lock Password Option.

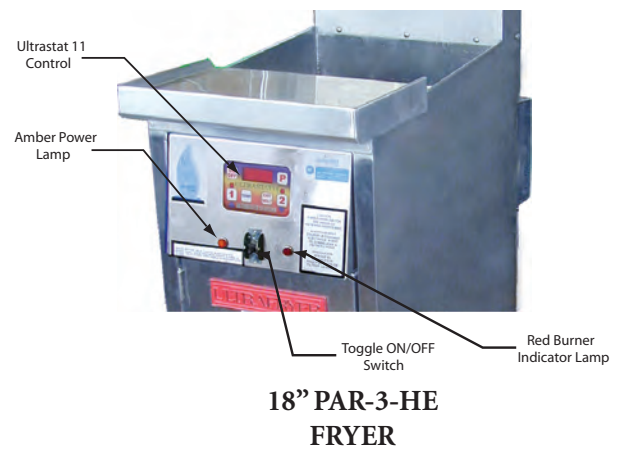

NOTE: If the Temperature Probe **OPENS** or **SHORTS** the Cook Mode will be **CANCELED**, the heating element will be turned **OFF**, and the computer key will be **INHIBITED**.

- 3. OPERATION** - Prior to operating the Model PAR-3-HE Gas Fryer, **ENSURE** the Filter Tub Assembly is properly installed and **DOCKED** to the fryer's Bulkhead Socket and the Temperature Control Access Door is closed, the fryer vat is filled with shortening to the middle of the "E" in the word **LEVEL** of the shortening level mark on the rear wall of the vat; then:
- Turn the Toggle ON/OFF Power Switch to the **OFF** Position.
 - Turn the **MANUAL** gas valve to the **OFF** position and wait **FIVE (5)** minutes for any accumulated gas to disperse.
 - ENSURE** the **MAIN** gas shut-off valve is in the **ON** position and the vent hood **EXHAUST FAN** is **ON**.
 - Turn the **MANUAL** gas valve to the **ON** position.
 - Perform the following steps, in the order listed in paragraph F on the next page.

E. ULTRASTAT 11 COOKING COMPUTER OPERATION

NOTE: Ultrastat 11 Cooking Computers will be programmed by Ultrafryer Systems for cooking products at 350°F (177°C) for 3 minutes.

<u>ITEM</u>	<u>ACTION</u>	<u>RESPONSE</u>
1	ENSURE the drain valve on the fryer is in the CLOSED position, shortening is at the proper level, the fryer TOGGLE ON/OFF switch is ON ; then depress the ON/OFF key on the Ultrastat 11 Cooking Computer.	A. The AMBER Power Lamp beside the Fryer Toggle ON/OFF Switch will LIGHT . B. <i>CYP</i> will appear in the display indicating the computer is in the PURGE MELT MODE . C. Each time the computer turns the heat mechanism ON a “dot” will appear in front of <i>CYP</i> and the red indicator lamp besides the fryer TOGGLE ON/OFF switch will LIGHT .
2	When shortening is heated depress the EXIT MELT key on the computer.	A. <i>HEAT</i> will appear in the display indicating the computer is in the FULL ON mode and has turned the BURNER ON until SETPOINT temperature is reached.
3	When <i>droP</i> appears in the display indicating shortening is at the SETPOINT temperature: 1- Drop the product to be cooked 2- Depress either the 1 ▲ or 2 ▼ key to start the cook cycle.	A. <i>3.00</i> will appear in the display indicating the product cook time and will immediately start counting DOWN . B. The lamp above 1 ▲ / 2 ▼ will BLINK to indicate that the timer is in use. C. Each time the computer turns the burner ON , a “dot” will appear before the time and the RED indicator lamp besides the fryer TOGGLE ON/OFF switch will LIGHT .
4	When the time displayed counts down to <i>0:00</i> the alarm will be turned ON to alert the cook that the cook cycle is ended. At this time: 1 - Remove the product from the shortening 2 - Depress the 1 ▲ or 2 ▼ key to turn the alarm OFF and reset the timer.	A. <i>droP</i> will appear in the display to indicate that the timer is ready for another cook cycle.
5	Repeat steps 2,3 and 4 to start additional cook cycles.	
<p>NOTES: 1 - To display the ACTUAL shortening temperature, depress the TEMP key ONE (1) time. 2 - To display the SETPOINT temperature, depress the TEMP key TWO (2) times. 3 - To display the TIME remaining in a cook cycle, depress the TEMP key THREE (3) times. 4 - Steps 1, 2, 3 and 4 will have to be repeated each time any of the following occurs: DRAIN VALVE IS OPENED FRYER TOGGLE ON/OFF SWITCH IS TURNED OFF TO FILTER SHORTENING OR BOILOUT A FRYER FRYER TOGGLE ON/OFF SWITCH IS TURNED OFF AT CLOSING</p>		

NOTE: For more detailed information on the Ultrastat 11 Cooking Computer including how to program the computer refer to the Ultrastat 11 Cooking Computer Operating Instructions PN 30A053 provided with the fryer.

FILTER TUB ASSEMBLY & INSTALLATION

A. **FILTER TUB ASSEMBLY** - ENSURE all components of the filter tub have been thoroughly cleaned and that the Filter Screen has been assembled according to the Cleaning Section, pages 27 - 30 of this manual; then assemble the filter tub as follows:

1. Connect the **KNURLED KNOB** to the **STANDPIPE DOCKING HANDLE ASSEMBLY**; then attach this assembly to the **SUCTION FITTING** on the Filter Screen.

DO NOT OVERTIGHTEN THIS CONNECTION!!!

2. Place the Filter Screen in the bottom of the Filter Tub with the screen butted against the rear wall of the tub.
3. Insert the Crumb Catcher Screen in the Filter Tub with the Drain Valve **DOCKING FLANGE** and **MALE DOCKING PLUG** over the leading edge of the pan.
4. Position the **FILTER TUB COVER** on the open end of the Filter Tub with the **SLOT** on the cover seated around the Stand pipe Docking Handle Assembly. Then, **SECURE** the cover to the standpipe assembly by locking the latch on the cover.

B. **FILTER TUB INSTALLATION** - Position the **ASSEMBLED** Filter Tub in front of the **FILTER TUB GUIDES** beneath the fryer; then **CAREFULLY** insert the Filter Tub into the fryer using the standpipe handle assy until the **MALE In-Line Plug** on the Docking Handle Assembly seats in the **FEMALE Bulkhead Socket** adjacent to the Drain Valve Assembly.

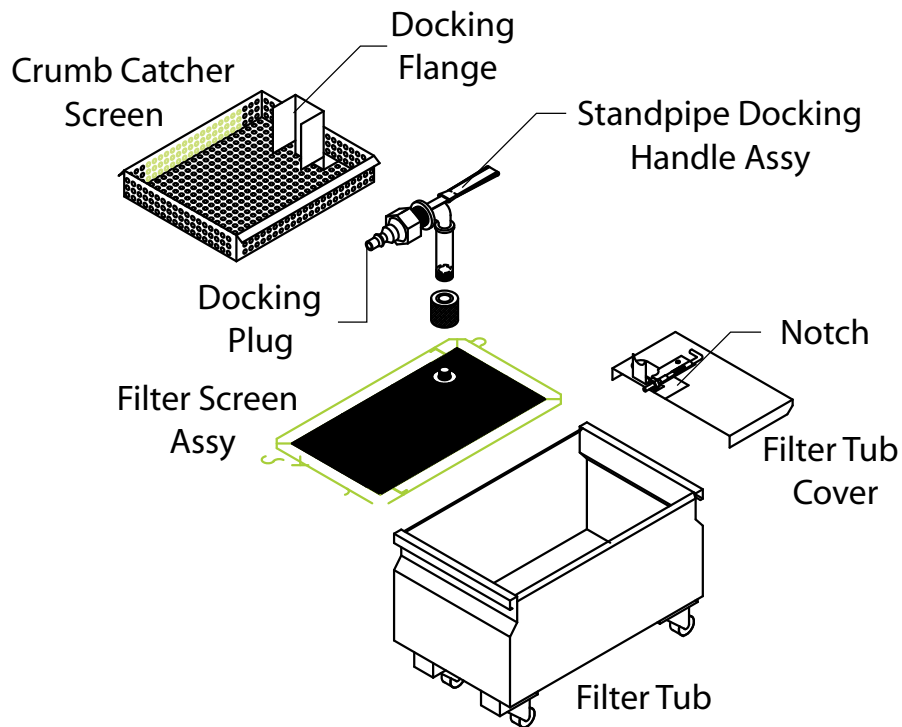

FILTERING & POLISHING SHORTENING

A. FILTERING SHORTENING

1. Turn the **TOGGLE ON / OFF SWITCH** to the fryer **OFF**, turn the **MANUAL GAS VALVE OFF**, and ensure the filter tub is properly docked beneath the drain valve.

NOTE: Pull on the filter tub Handle to **ASSURE** the male docking plug is **SEATED** in the female bulkhead socket.

2. Place the amount of **FILTER AGENT** into the fryer vat as prescribed in the cleaning manual provided by your chemical supplier; thoroughly stir the filter agent into the shortening using a skimmer; then skim the shortening to remove any floating crumbs.

CAUTION: PRIOR TO PROCEEDING TO THE NEXT STEP, PUT ON SAFETY GOGGLES, NEOPRENE INSULATED GLOVES AND AN APRON.

3. Carefully attach the drain valve handle to the drain valve; then open the drain valve by turning the **DRAIN VALVE HANDLE** slightly downward. When the bottom of the filter tub is covered with about two (2) inches of shortening, completely **OPEN** the drain valve, and while shortening is draining, scrape all sides of the vat to remove encrusted material using the scraper.
4. When all shortening has drained into the filter tub, use the **DRAIN ROD** to stand the wire rack on one side of the vat.
5. Use the drain rod to pull the sediment on the bottom of the vat towards the valve opening, then use the rod to push sediment through the valve opening.

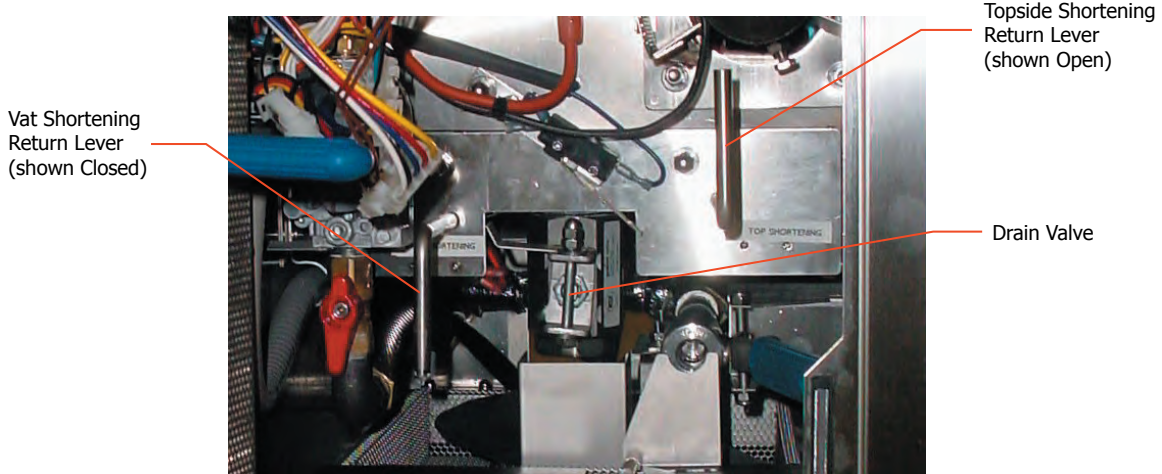

CAUTION: DO NOT ACTIVATE (TURN) THE VAT SHORTENING RETURN LEVER AND TOPSIDE SHORTENING LEVER AT THE SAME TIME! TO DO SO WILL REDUCE SHORTENING FLOW.

6. If there is **NO** sediment or debris visible on the heat exchanger or bottom of the vat, **CLOSE** the drain valve; then turn the **LEFT HAND** Vat Shortening Return Lever $\frac{1}{4}$ **turn counter clock wise** to automatically return shortening in the filter tub through the **SWEEP NOZZLE** in the bottom of the vat. When all shortening has been returned to the vat, turn the **LEFT HAND** Vat Shortening Return Lever $\frac{1}{4}$ **turn clockwise** to stop the flow of shortening; then proceed to page 41.
7. If there is considerable sediment and debris on the bottom of the vat, **FLUSH** this sediment from vat using the Wash Down Hose or **OPTIONAL** Automatic Vat Cleaner (AVC) also referred to as **SPRAY BLASTER**, as described below.

a. Fryer **WITHOUT** an Automatic Vat Cleaner (AVC) <Spray Blaster>

- 1) Leave the drain valve in the **OPEN** position, **CAREFULLY** connect the Wash Down Hose **Male** In-Line Plug to the **TOPSIDE FEMALE SOCKET**; then place the Wash Down Hose nozzle into vat and hold it firmly against an inner wall so it will not recoil upward when the pump comes on.
- 2) Turn the **RIGHT HAND** Topside Shortening Return Lever $\frac{1}{4}$ **turn counter clock wise** and hold the hose nozzle at a 45° angle from the bottom of the vat causing sediment and debris to bounce off the rear wall and flow towards the drain valve.

- 3) Use the “L” shaped brush to push the sediment through the drain valve to keep the drain clear. Hose off the heat exchanger and vat walls until all sediment and debris has been flushed through the drain into the filter tub.
 - 4) Turn the **RIGHT HAND** Topside Shortening Return Lever $\frac{1}{4}$ **turn counter clock wise**; then **CAREFULLY** remove the Wash Down Hose **MALE** In-Line Plug from the **TOPSIDE FEMALE SOCKET** by depressing the Topside Socket Release Knob.
 - 5) Hang the Wash Down Hose in an up-right position so shortening can drain into a metal container; then proceed to paragraph B 1 page 42.
- b. Fryer **WITH** an Automatic Vat Cleaner (AVC).
- 1) With the Drain Valve in the **OPEN** position, **CAREFULLY** place the AVC (Spray Blaster) on the fryer’s **TOPSIDE HANGER BRACKET** and **SECURELY** connect the **MALE** In-Line Plug on the AVC to the **TOPSIDE FEMALE SOCKET**.
 - 2) Turn the **RIGHT HAND** Topside Shortening Return Lever $\frac{1}{4}$ **turn counter clock wise** to allow shortening in the filter tub to be discharged into the vat through the four (4) nozzles in the bottom of the spray blaster, flushing sediment and debris through the drain valve. When all sediment and debris has been flushed from the vat, turn the Topside Shortening Return Lever $\frac{1}{4}$ **turn clock wise**, remove the male in-line plug on the Spray Blaster from the Topside Female Socket by depressing the Topside Release Knob.
 3. **CAREFULLY** remove the **HOT** Automatic Vat Cleaner from the hanger bracket, and **THOROUGHLY** clean it in a 3 compartment sink.
 4. Proceed to paragraph B 1 page 42.

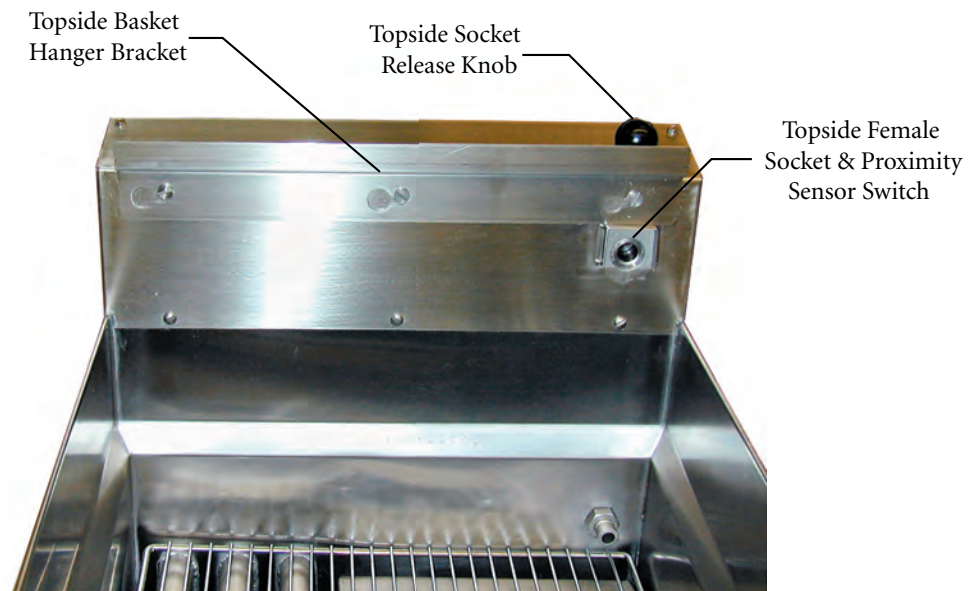

B. POLISHING SHORTENING

1. Set a timer for the amount of time established for **POLISHING** shortening, then turn the **VAT SHORTENING RETURN LEVER 1/4 TURN COUNTER CLOCKWISE** to allow shortening to circulate through the system to **POLISH** the shortening.

CAUTION: DO NOT POLISH THE SHORTENING MORE THAN THE ESTABLISHED TIME AS IT WILL PUMP EXCESS AIR INTO THE SHORTENING CAUSING SHORTENING BREAKDOWN.

2. At the end of the established time, **TURN** the **VAT SHORTENING RETURN LEVER 1/4 TURN COUNTER CLOCKWISE**, turn the **DRAIN VALVE HANDLE** to the closed **UP** position; replace the grill in the fryer; then **TURN** the **Vat Shortening RETURN LEVER 1/4 COUNTER CLOCKWISE** to automatically return shortening in the filter tub to the fryer vat.
3. When all shortening in the filter tub has been returned to the fryer, **TURN** the **VAT SHORTENING RETURN LEVER, 1/4 TURN COUNTER CLOCKWISE** check and if necessary add fresh shortening so shortening is level with the middle line of the letter “E” in the word **LEVEL** of the shortening level mark on the rear wall of the fryer.
4. Remove the Filter Tub Assembly by pressing the **DOCKING RELEASE HANDLE** and pulling the **STANDPIPE DOCKING HANDLE ASSY** away from the **FEMALE** Bulkhead Socket adjacent to the Drain Valve; then **THOROUGHLY** clean, assemble and replace the Filter Tub Assembly in the fryer cabinet.

SHORTENING DISPOSAL, BOIL-OUT& SHORTENING INSTALLATION

- A. **GENERAL** -The Model PAR-3-HE Gas Fryer should be **BOILED-OUT** every **7 DAYS** to remove carbon buildup and other encrusted material.

B. SHORTENING DISPOSAL

1. **CAREFULLY** assemble the Filter Tub assembly according to paragraph A page 38 and **CAREFULLY** install it in the fryer cabinet according to paragraph B page 38.

CAUTION: PRIOR TO PROCEEDING TO THE NEXT STEP, PUT ON SAFETY GOGGLES, NEOPRENE INSULATED GLOVES AND AN APRON.

2. Turn the Toggle ON/OFF switch and Manual Gas Valve **OFF**, and ensure the filter tub is properly **DOCKED** beneath the fryer drain valve.

NOTE: Pull on the filter tub to **ASSURE** the male docking plug is **SEATED** in the female bulkhead socket.

3. Attach the Drain Valve Handle to the drain valve; then open the drain valve by turning the **DRAIN VALVE HANDLE** slightly downward. When the bottom of the filter tub is covered with about two (2) inches of shortening, completely **OPEN** the drain valve, and while shortening is draining, scrape all sides of the vat to remove encrusted material using a scraper.
4. When all shortening has drained into the filter tub, use the **DRAIN ROD** to place the wire rack on one side of the vat.
5. Use the drain rod to pull sediment on the bottom of the vat towards the drain valve opening and push it through the valve opening.
6. Use one (1) of the following procedures to **FLUSH** sediment and debris from the fryer vat:
 - a. Fryer **WITHOUT** an Automatic Vat Cleaner:
 - 1) **CAREFULLY** connect the Wash Down Hose **MALE** In-Line Plug to the **TOPSIDE FEMALE SOCKET** and place the Wash Down Hose into the vat and hold it firmly against an inner wall so it will not “recoil” upward when the pump comes **ON**.
 - 2) **TURN** the Topside Shortening Return Lever 1/4 turn counter clockwise and hold the wand hose nozzle at a 45° angle from the bottom of the fryer causing sediment and debris to bounce off the rear wall of the vat and flow towards the drain valve.
 - 3) Use the “L” shaped vat brush to push the sediment through the drain valve to keep the drain clear. Hose off the burner tubes and all walls of the vat until all the sediment and residue at the bottom of the fryer has been flushed through the drain into the filter tub. Then turn the Topside Shortening Return Lever 1/4 turn clockwise.
 - b. Fryer **WITH** an Automatic Vat Cleaner (AVC):
 - 1) **CAREFULLY** position the **AVC (SPRAY BLASTER)** on the fryer and **SECURELY** connect the **MALE** In-Line Plug on the Spray Blaster flexible hose to the **TOPSIDE FEMALE SOCKET**.
 - 2) **TURN** the Topside Shortening **RETURN LEVER 1/4 TURN COUNTER CLOCKWISE** to allow shortening in the filter tub to be discharged in the vat through the four (4) nozzles in the bottom of the Spray Blaster flushing sediment and debris through the drain valve.

- 3) When all sediment and debris has been flushed from the vat, **TURN** the Topside Shortening **RETURN LEVER 1/4 CLOCKWISE** and **CAREFULLY** remove the **HOT** Spray Blaster by depressing the **TOPSIDE SOCKET RELEASE KNOB**; then **THOROUGHLY** clean the Spray Blaster in a 3 compartment sink.
- 4) **CAREFULLY** connect the Wash Down Hose **MALE** In-Line Plug to the **TOPSIDE FEMALE SOCKET**; place the Wash Down Hose into the vat and hold it firmly against an inner wall so it will not “recoil” upward when the pump comes **ON**.

SHORTENING DISPOSAL, BOIL-OUT & INSTALLATION

A. **GENERAL** -The Model PAR-3-HE Gas Fryer should be **BOILED-OUT** every **7 DAYS** to remove carbon buildup and other encrusted material.

B. SHORTENING DISPOSAL

1. **CAREFULLY** assemble the Filter Tub assembly according to paragraph A page 38 and **CAREFULLY** install it in the fryer cabinet according to paragraph B page 38.

CAUTION: PRIOR TO PROCEEDING TO THE NEXT STEP, PUT ON SAFETY GOGGLES, NEOPRENE INSULATED GLOVES AND AN APRON.

2. Turn the Toggle ON/OFF switch and Manual Gas Valve **OFF**, and ensure the filter tub is properly **DOCKED** beneath the fryer drain valve.

NOTE: Pull on the filter tub to **ASSURE** the male docking plug is **SEATED** in the female bulkhead socket.

3. Attach the Drain Valve Handle to the drain valve; then open the drain valve by turning the **DRAIN VALVE HANDLE** slightly downward. When the bottom of the filter tub is covered with about two (2) inches of shortening, completely **OPEN** the drain valve, and while shortening is draining, scrape all sides of the vat to remove encrusted material using a scraper.
4. When all shortening has drained into the filter tub, use the **DRAIN ROD** to place the wire rack on one side of the vat.
5. Use the drain rod to pull sediment on the bottom of the vat towards the drain valve opening and push it through the valve opening.
6. Use one (1) of the following procedures to **FLUSH** sediment and debris from the fryer vat:
 - a. Fryer **WITHOUT** an Automatic Vat Cleaner:
 - 1) **CAREFULLY** connect the Wash Down Hose **MALE** In-Line Plug to the **TOPSIDE FEMALE SOCKET** and place the Wash Down Hose into the vat and hold it firmly against an inner wall so it will not “recoil” upward when the pump comes **ON**.
 - 2) **TURN** the Topside Shortening Return Lever 1/4 turn counter clockwise and hold the wand hose nozzle at a 45° angle from the bottom of the fryer causing sediment and debris to bounce off the rear wall of the vat and flow towards the drain valve.
 - 3) Use the “L” shaped vat brush to push the sediment through the drain valve to keep the drain clear. Hose off the burner tubes and all walls of the vat until all the sediment and residue at the bottom of the fryer has been flushed through the drain into the filter tub. Then turn the Topside Shortening Return Lever 1/4 turn clockwise.
 - b. Fryer **WITH** an Automatic Vat Cleaner (AVC):
 - 1) **CAREFULLY** position the **AVC (SPRAY BLASTER)** on the fryer and **SECURELY** connect the **MALE** In-Line Plug on the Spray Blaster flexible hose to the **TOPSIDE FEMALE SOCKET**.
 - 2) **TURN** the Topside Shortening **RETURN LEVER 1/4 TURN COUNTER CLOCKWISE** to allow shortening in the filter tub to be discharged in the vat through the four (4) nozzles in the bottom of the Spray Blaster flushing sediment and debris through the drain valve.
 - 3) When all sediment and debris has been flushed from the vat, **TURN** the Topside Shortening **RETURN LEVER 1/4 CLOCKWISE** and **CAREFULLY** remove the **HOT** Spray Blaster by depressing the **TOPSIDE SOCKET RELEASE KNOB**; then **THOROUGHLY** clean the Spray Blaster in a 3 compartment sink.
 - 4) **CAREFULLY** connect the Wash Down Hose **MALE** In-Line Plug to the **TOPSIDE FEMALE SOCKET**, place the Wash Down Hose into the vat and hold it firmly against an inner wall so it will not “recoil” upward when the pump comes **ON**.
7. **DISPOSE** of the shortening in the filter tub as follows:
 - a. Restaurants **NOT** equipped with a Shortening Disposal System.
 - 1) Place the Wash Down Hose **NOZZLE** into a **METAL** container and hold it firmly against an inner wall.
 - 2) **TURN** the **TOPSIDE SHORTENING RETURN LEVER 1/4 TURN COUNTER CLOCKWISE** and pump shortening into the metal container.
 - 3) When all shortening has been pumped into the container, **TURN** the **TOPSIDE SHORTENING RETURN LEVER 1/4 TURN CLOCKWISE**, remove the Wash Down Hose from the **TOPSIDE FEMALE SOCKET** and hang the hose in an upright position so shortening in the hose can drain into a container.
 - b. Restaurants equipped with a Shortening Disposal system.
 - 1) **SECURELY** connect the Shortening Disposal Hose fitting to the **TOPSIDE FEMALE SOCKET** and connect the fitting on the other end of the hose to the Disposal System connector on the wall.
 - 2) **TURN** the **TOPSIDE SHORTENING RETURN LEVER 1/4 TURN COUNTER CLOCKWISE** and pump shortening in the filter tub into the Exterior rendering tank.

- 3) When all shortening has been pumped into the rendering tank, **TURN** the **APPLICABLE TOPSIDE SHORTENING RETURN LEVER 1/4 TURN CLOCKWISE**, remove the Disposal Hose from the **TOPSIDE FEMALE SOCKET**. Hang the hose in an upright position so shortening in the hose can drain into a container.

8. **THOROUGHLY** clean and re-assemble the filter tub.

- C. **BOIL-OUT** - Boil-out the PAR-3-HE Gas Fryer following the cleaning instructions in the Cleaning Manual provided by your approved chemical supplier. The following are generic procedures:

DTMR EQUIPPED FRYER

1. Ensure the Drain Valve Handle is in the closed (UP) position, then add water to the fryer vat until it reaches a point one (1) inch (25 mm) **BELOW** the middle line of the “E” in the word **LEVEL** on the rear wall of the fryer.
2. Add the amount of **BOIL-OUT COMPOUND** to the fryer vat as prescribed in the Cleaning Manual provided by the Chemical Supplier.
3. Turn the Toggle ON/OFF Switch and manual Gas Valve for the fryer to the **ON** position, depress and release the **START** button; then depress and release the **EXIT MELT** button on the DTMR.
4. When the boil-out solution starts to **BOIL** set a timer for 30 minutes and frequently scrub the sides, front and back of the vat with a long handled scrub brush.

NOTE: If the boil-out solution starts to boil over, shut the fryer **OFF** for a few minutes and add water as necessary, then turn it back **ON**.

5. While the fryer is being **BOILED OUT**, clean the filter tub assembly according to procedures in the cleaning section.
6. When the timer sounds, turn the Toggle ON/OFF Switch and Manual Gas Valve for the fryer to the **OFF** position and **CAREFULLY** dispose of the boil-out solution in the fryer in a floor drain.
7. Use a scrubbing pad to remove carbon build-up from the top of the burner. To remove carbon build-up on the sides and bottom of the heat exchanger, slide one end of a stropping pad under each heat exchanger, grasp that end with a pair of tongs and rock the pad up and down along the length of each heat exchanger until all encrusted material has been removed. Replace the wire rack in the fryer.
8. Rinse the fryer with hot water until the water coming out of the drain valve is clear.
9. Mix a solution of **ONE PART** vinegar to **25 PARTS** of water. Place this mixture into a one-gallon garden pressure sprayer and **THOROUGHLY** spray this solution onto the **SIDES, BURNER TUBES** and **BOTTOM** of the fryer to neutralize the Boil-Out Compound.

NOTE: Boil-Out Compound will cause shortening to break down rapidly if it is not neutralized.

10. **THOROUGHLY** wipe the sides, burner tubes and bottom of the fryer with clean, lint-free, dry towels to remove any remaining water, turn the **DRAIN VALVE** to the closed UP position; then fill the fryer with **NEW** shortening to the shortening level mark as described in paragraph D on the next page.

ULTRASTAT 11 EQUIPPED FRYER

1. Ensure the Drain Valve Handle is in the closed (UP) position, then add water to the fryer vat until it reaches a point **ONE** (1) inch (25mm) **BELOW** the middle line of the “E” in the word **LEVEL** of the **HIGH** level mark on the rear wall of the fryer.
2. Add the amount of **BOIL-OUT COMPOUND** to the fryer vat as prescribed in the Cleaning Manual provided by the Chemical Supplier.
3. Turn the Toggle ON/OFF switch and the Manual Gas Valve for the fryer to the **ON** position; then depress the ON/OFF key on the computer.
4. Depress the “**P**” key to enter the program mode and adjust the time of the **LEFT HAND** timer for 30 minutes.
5. Depress the “**P**” key **TWO** (2) times; then adjust the temperature for **190°F (88°C)**.
6. Depress and **HOLD** the “**P**” key for 3 seconds to **EXIT** the program mode.
7. Depress the **EXIT MELT** key on the computer to place the fryer in the **FULL ON** mode and when the **WATER** reaches 190°F (88°C), depress the 1 key to start the **LEFT HAND** timer; then frequently scrub the sides, front and back of the vat with a long handle scrub brush.
8. When the timer sounds, turn the Toggle ON/OFF switch and Manual Gas Valve for the fryer to the **OFF** position and **CAREFULLY** dispose of the boil-out solution in the fryer in a floor drain.
9. Use a scrubbing pad to remove carbon build-up from the top of the heat exchanger. To remove carbon build-up on the sides and bottom of the heat exchanger, slide one end of a stropping pad under each heat exchanger, grasp that end with a pair of tongs and rock the pad up and down along the length of each heat exchanger until all encrusted material has been removed. Replace the wire rack in the fryer.
10. Rinse the fryer with hot water until the water coming out of the drain valve is clear.
11. Mix a solution of **ONE PART** vinegar to **25 PARTS** of water. Place this mixture into a one-gallon garden pressure sprayer and **THOROUGHLY** spray this solution onto the **SIDES, BURNER TUBES** and **BOTTOM** of the fryer to neutralize the boil-out compound.

NOTE: BOIL-OUT COMPOUND WILL CAUSE SHORTENING TO BREAKDOWN RAPIDLY IF NOT NEUTRALIZED.

12. **THOROUGHLY** wipe the sides, burner tubes and bottom of the fryer with clean, lint-free, dry towels to remove any remaining water; turn the **DRAIN VALVE HANDLE** to the closed “**UP**” position; then fill the fryer with **NEW** shortening to the applicable shortening level mark, as prescribed below.
13. Reprogram the Ultrastat 11 Cooking Computer for the correct cook time and temperature.

D. SHORTENING INSTALLATION

WARNING!!! TO AVOID INJURY

- I DO NOT MOVE A FRYER FILLED WITH HOT LIQUID.**
- II THE FRYER MUST BE RESTRAINED BY USE OF A RESTRAINING DEVICE TO PREVENT TIPPING AND TO AVOID THE SPLASHING OF HOT LIQUID.**
- III THE AREA SURROUNDING THE FRYER MUST BE KEPT FREE AND CLEAR OF ALL COMBUSTIBLES.**
- IV DO NOT GO NEAR THE AREA DIRECTLY OVER THE FLUE OUTLET WHEN THE FRYER’S MAIN BURNERS ARE OPERATING.**
- V ALWAYS WEAR OIL-PROOF, INSULATED GLOVES WHEN WORKING WITH A FRYER FILLED WITH HOT OIL.**
- VI ALWAYS DRAIN HOT OIL INTO A METAL TUB, POT OR CAN ... HOT OIL CAN MELT PLASTIC BUCKETS OR SHATTER GLASS CONTAINERS.**

1. **LIQUID SHORTENING:** When using liquid shortening fill the fryer with cool shortening 1/2” (13mm) **BELOW** the “**E**” in the word **LEVEL**. When heated ensure shortening is even with the middle line of the “**E**” in the word **LEVEL**.
2. **SOLID SHORTENING:**
 - a. Cut a block of solid shortening into small pieces.
 - b. Place small pieces of solid shortening **EVENLY** on top of the **HEAT EXCHANGER TUBES** or **THOROUGHLY PACK** these pieces of solid shortening between, below and above the **HEAT EXCHANGER TUBES**. While packing solid shortening is messy and time consuming, it is the safest and fastest way to melt solid shortening.
 - c. DTMR equipped Fryer
 - 1) Turn the fryer Toggle **ON/OFF** switch **ON**; then place the Default-to-Manual-Restart (DTMR) Control in the **SHORTENING MELT MODE** by depressing then releasing the momentary **START** button on the DTMR. The **RED START** lamp and **AMBER MELT MODE** lamp will light to indicate the fryer is in the melt mode.
 - 2) When the **HEAT EXCHANGER TUBES** are **COMPLETELY** covered with **HEATED LIQUID** shortening, replace the grill in the fryer vat; then push the **EXIT MELT** button on the DTMR and proceed to paragraph e below.
 - d. Ultrastat 11 equipped Fryer
 - 1) Turn the fryer Toggle **ON/OFF** switch **ON**; then place the computer in the **SHORTENING MELT MODE** by depressing the **ON/OFF** key. **C Y P** will appear in the display indicating the computer is in the **PURGE MELT MODE**, and the **RED** burner indicator lamp on the fryer will cycle **ON** and **OFF** indicating the burner is being turned **ON** and **OFF** to gently heat the shortening.
 - 2) When the heat exchanger tubes are **COMPLETELY** covered with **LIQUID** shortening and the shortening is **ABOVE 100°F (38°C)**, replace the grill in the fryer vat; then push the **EXIT MELT** key on the computer.
 - e. Continue adding solid shortening as follows:
 - 1) Place small pieces of solid shortening into a fry basket.
 - 2) **CAREFULLY** lower the basket into the fryer vat.
 - 3) **GENTLY** turn the basket to allow these pieces of solid shortening to float away.
 - 4) Repeat the above steps until liquid shortening is even with the middle line of the “**E**” in the word **LEVEL** of the shortening level mark on the rear wall of the fryer vat.

TECHNICAL ASSISTANCE, ORDERING INFORMATION & PARTS IDENTIFICATION

A. **TECHNICAL ASSISTANCE** - Contact an authorized service agent or the Customer Service Department, Ultrafryer Systems at 1-800-525-8130 for technical assistance.

B. ORDERING INFORMATION:

1. **REPLACEMENT PARTS** - Provide the following information when ordering replacement parts by phone, fax or mail:

Your company name and phone number
Your company purchase order number
Bill-to address
Ship-to address
Quantity desired
Part number and description of the desired-item
Your name or signature of authorized-buyer
Phone in order to: 1-800-545-9189 Ext 5029
FAX order to: 1-210-731-5099
Mail order to: Ultrafryer Systems
Order Entry Office
P.O. Box 5369
San Antonio, TX 78201
E-Mail your order to: Ultrafryerservice@ultrafryer.com

2. **TERMS** - Net 30 days for customers on approved accounts. Past due balances will be charged 1% per month (12% per annum) until full balance is paid.

3. **DAMAGES** - Ultrafryer Systems is not responsible for damage occurring in transit. All deliveries must be inspected for damage to shipping containers prior to departure of the delivering carrier. Any damage must be notated on the receiving document to facilitate filing of freight claims. Carriers must be notified immediately and freight inspections must be requested from the carrier. Ultrafryer Systems can and will gladly assist you in preparing and processing of the necessary claims only if proper notification has been accomplished on the carrier delivery document. Damaged equipment and or containers must be available for the claims inspector to inspect.

4. **RETURNS** - Ultrafryer Systems cannot guarantee credit for items returned without proper authorization. All returns must have prior Ultrafryer Systems Customer Service or Warranty department approval. An assigned number will be issued by the approval authority. Please print the assigned number on all returned packages and corresponding paperwork. Returned goods are subject to a 15% restocking charge. Ultrafryer Systems is not responsible for freight charges on returned goods unless authorized by Customer Service and or Warranty personnel. Ultrafryer Systems does not receive freight collect or C.O.D. shipments.

C. **PARTS IDENTIFICATION** - Locate the part on the following sketches and note the index number i.e, 3, 6, etc; then obtain the part number and description for that index number on the page facing the sketches. Use that part number when ordering a replacement part.

ULTRAFRYER MODEL PAR-3-HE GAS FRYER
FRONT VIEW

18" PAR-3-HE

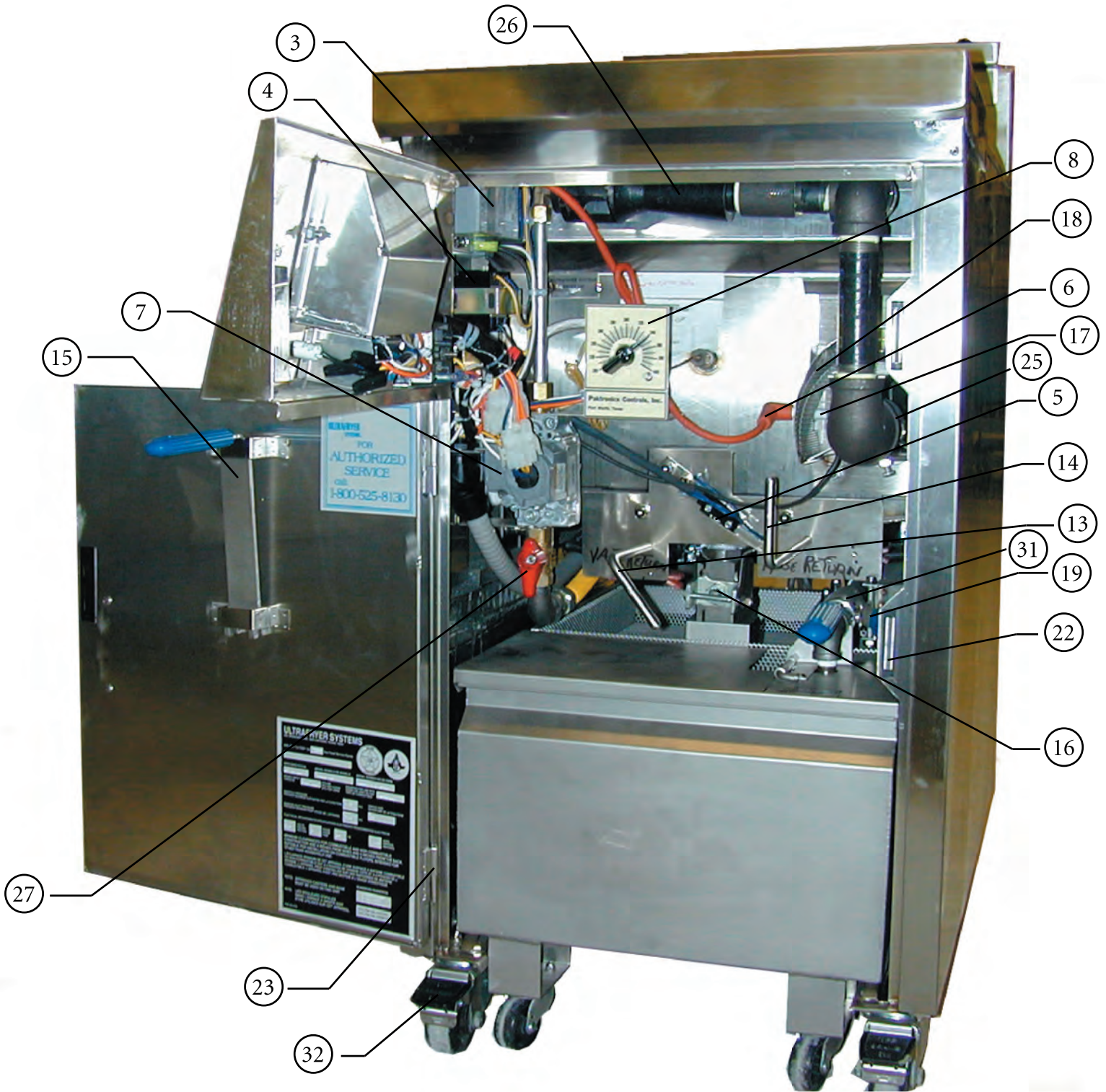

	ITEM	DESCRIPTION	PN
*	01	Drain Clean-out Rod	12569
*	02	18" Model PAR-3-HE Vat Cover	19A731
*	03	Model S87B1008 Spark Ignitor Module	18179
	04	120 Volt to 24 Volt Step-Down Transformer	18180
	05	Drain and Filter Valve Lever Microswitch	18185
	06	Model 39212S-1 Ignitor Rod Cable w/plugs	18187
	07	Electric Gas Combination Control Valve	18227
*	08	Electronic Thermostat for use with Default-to-Manual-Restart (DTMR) Control PN 12B014 Temperature Sensing Probe for use with Ultrastat Cooking Computers.	12B077 18A006
*	09	Delay on Make Relay (NOTE: Set Relay to "4" prior to installation).	18A045
*	10	Proximity Switch Sensor	18A060
*	11	Hi-Limit Switch Pre-Set to trip at 400° F (204°C). ((Order a ¼" (5mm) Compression Fitting PN 24-247 when ordering this item.))	19A144
*	12	18" Model PAR-3-HE Agitator Baffle Weldment	19A474
	13	18" Model PAR-3-HE Vat Shortening Return Lever	19B512
	14	18" Model PAR-3-HE Topside Shortening Return Lever	19B513
	15	Drain Ball Valve Handle	19A558
	16	Drain Ball Valve Assembly	19A564
	17	Ignitor Spark Rod Assembly w/Ignitor Rod (Set Rod Gap to VVE" (4mm) prior to installation)	19A738
	18	Sound Weldment Baffle	19A739
	19	Docking Release Handle	19A948
*	20	18" Model PAR-3-HE F/F Basket Hanger Bracket	19B313
*	21	Chrome Door Pull	22005
	22	Magnetic Door Catch	22407
	23	Lift-Off Door Hinge	22640
*	24	18" Model PAR-3-HE Fryer Vat Grill	22704
	25	Ferrofix Nozzle Eclipse #GF-1 Burner	22A112
	26	Cast Iron Venturi	22A118
	27	½" (13mm) ID Manual Gas Valve w/Red Handle	24326
*	28	18" Model PAR-3-HE "Natural Gas" v" (11mm) Orifice Plug w/#10 Drill Hole (Order Orifice Plug PN 24A066 w/#32 Drill Hole for a "Propane" Fryer and Orifice Plug PN 24A067 w/#36 Drill Hole for a "Butane" Fryer.)	29A070
*	29	Orifice Plug Holder	24A105
*	30	½" (13mm) MPT x ½" (13mm) MPT Flexible Gas Line 18" (457mm) Long	24A138
	31	½" (13mm) FPT S/S Female Bulkhead Coupling w/Raised Button Release	24A209
	32	Medium Duty 3" (76mm) Front Caster w/Brake for all Model PAR-3-HE Fryers.	28A010
*	33	"L" Shaped Tip Cleaning Brush	29A044

* NOT SHOWN

**ULTRAFRYER MODEL PAR-3-HE GAS FRYER
REAR VIEW**

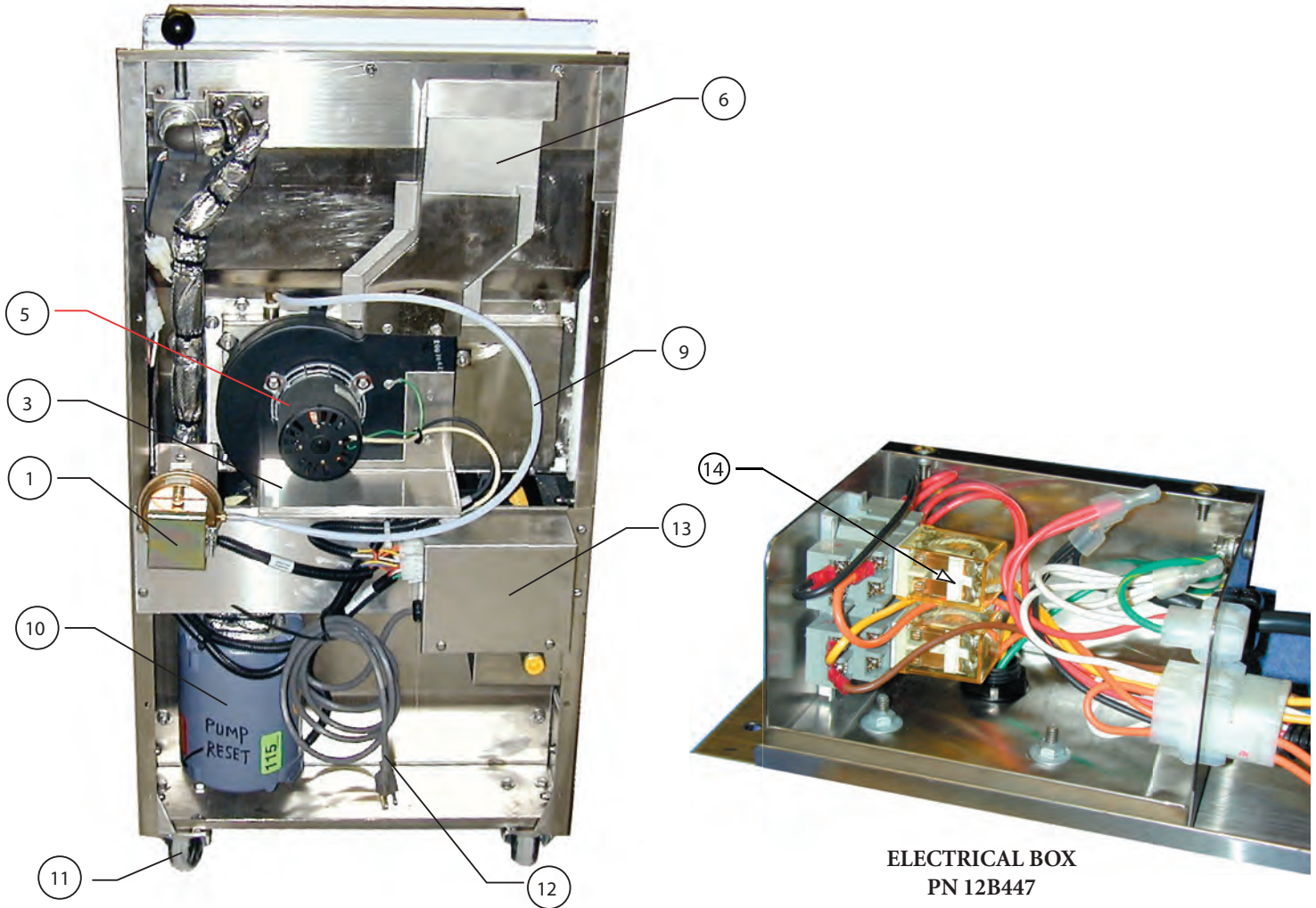

**ELECTRICAL BOX
PN 12B447**

<u>ITEM</u>	<u>DESCRIPTION</u>	<u>PN</u>
1	Model SMD 1204 Air Pressure Switch	18A291
3	Exhaust Blower Motor Drip Pan	19A527
* 4	18" Model PAR-3-HE Exhaust Blower Motor Gasket	19A546
5	18" Model PAR-3-HE 115 Volt 60 HZ Exhaust Blower Motor Kit w/Mounting Bracket	19A548
6	18" Model PAR-3-HE Rectangular Flue Tube with deflector	19B312
* 7	125 Volt 75 Watt Silicon Heater 5' (1524mm) Long	23341
* 8	Gemini ½" (13mm) Pump Ball Valve	24-036
9	x" (5mm) ID, c" (8mm) OD Air Pressure Switch Plastic Tube rated for 500° F (260°C)	24A068
10	Model GPV-0514 5.5 GPM (19.25 LPM) Viking Pump/Motor Kit. NOTE: For replacement, Pump Only order 24-339.	24A206
11	Medium Duty 3" (76mm) Rear Caster w/out Brake	28A011
12	Type SJO 16/3 Electrical Cord with 90° Molded Plug	33048
13	Electrical Box	12B447
14	120 VOLT 50/60 hz Relay	18A020

* NOT SHOWN

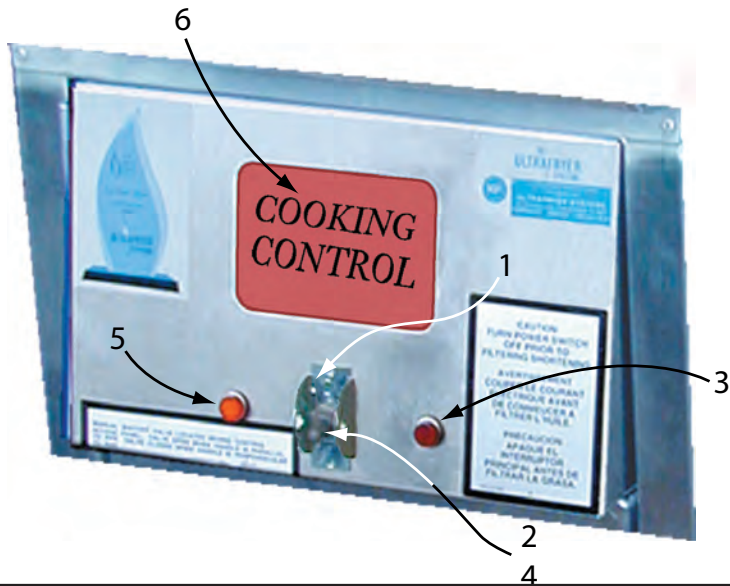

ITEM	DESCRIPTION	PN
1	Toggle On/Off Switch Guard.	18129
2	120 Volt 6 Amp SPDT Toggle ON/OFF Switch.	18A287
3	125 Volt 1/3 Watt Snaplight w/RED Lens.	23362
4	Toggle ON/OFF Switch Protective Boot.	23402
5	125 Volt 1/3 Watt Snaplight w/AMBER Lens.	23A056
6	COOKING CONTROLS Default-To-Manual-Restart (DTMR) Control f/ 14 & 18" Model PAR-3-HE. Uses Electronic Thermostat PN 12B077 Ultrastat 11 Cooking Computer (Uses Temperature Probe 18A006)	12B014 22A120

**ELECTRONIC THERMOSTAT
PN 12B077**

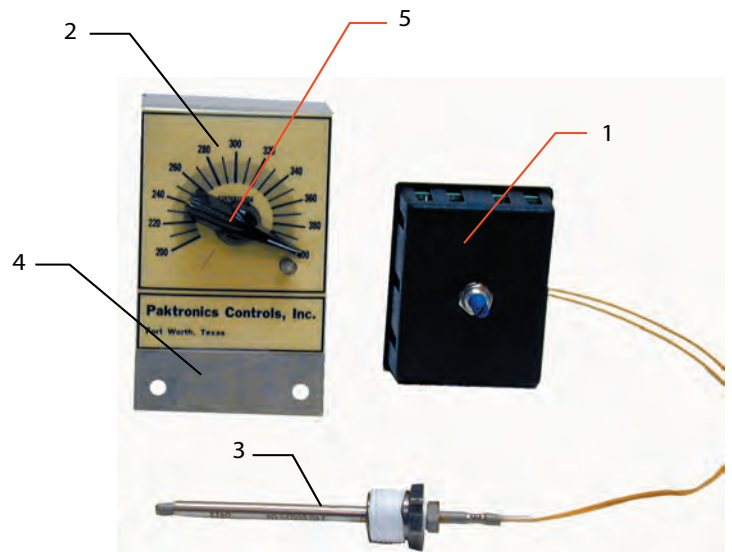

ITEM	DESCRIPTION	PN
1	Electronic P14 Thermostat	18A058
2	Electronic Thermostat Face Plate	18A070
3	Temperature Probe	18A276
4	Electronic P14 Thermostat Bracket	19B184
5	Electronic Thermostat Knob	22A169

PAR-3-HE Hard Dock FILTER TUB ASSEMBLY
18" With Micromesh Filter **PN 12B299**

ITEM	DESCRIPTION	PN
*1	Filter Tub Scraper	12567
2	Micromesh S/S Filter Screen Assembly with StandPipe & Docking Assembly	12B113
*3	Magepad Magnesol Impregnated Filter Pad with Standpipe and Docking Assembly	12B178
*4	Wash Down Hose Assembly	12B115
5	Filter Tub cover with hinge latch and Proximity sensor actuator for 18" Filter Tub	19B227
*6	Proximity Actuator Sensor	18A059
7	18" Model PAR-3-HE Filter Tub	19B309
8	18" Model PAR-3-HE Crumb Catcher Pan	19B308
9	RH s/s Hinge Latch	22479
10	Medium Duty Caster	28A005

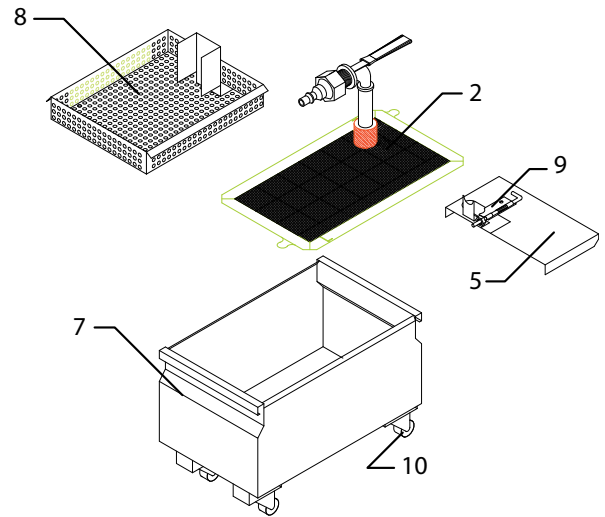

* NOT SHOWN

WASH DOWN HOSE ASSEMBLY
PN 12B115

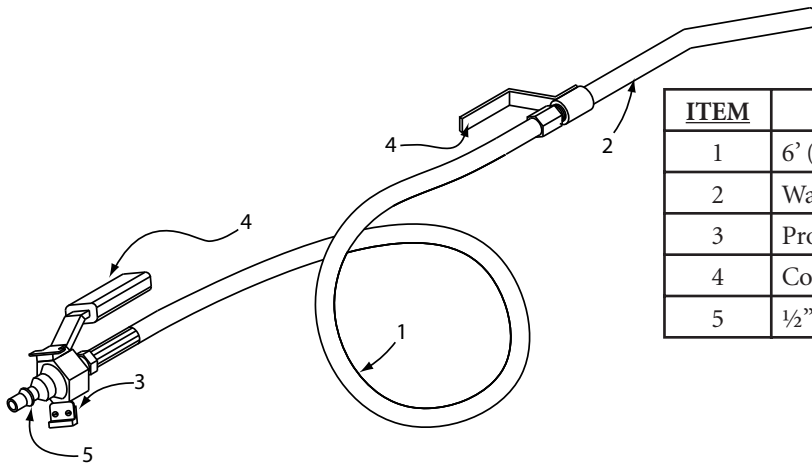

ITEM	DESCRIPTION	PN
1	6' (1829mm) Wash Down Hose w/Fittings	1254
2	Wash Down Hose & Nozzle Assembly	12675
3	Proximity Sensor Actuator	18A059
4	Cool II Handle	22734
5	½"(13mm) S/S Locking Seal Inline Plug	24A208

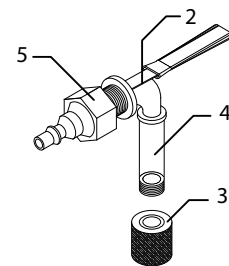

ITEM	DESCRIPTION	PN
1	Micro-Mesh S/S Filter Screen	21A278
2	Handle Assy, Weld ½"(13mm) Street Elbow	19B442
3	Top Compression Cap (Knurl Knob)	24369
4	3/8"(10mm) x 9" (229mm) Black Iron Nipple	24417
5	½"(13mm) S/S Locking Seal Inline Plug	24A208

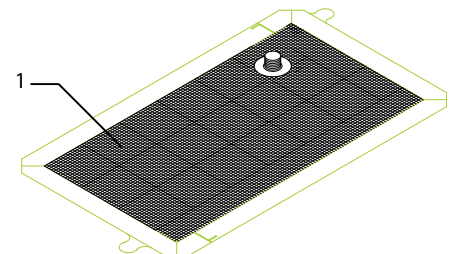

MICRO-MESH FILTER ASSEMBLY
WITH STANDPIPE & DOCKING ASSEMBLY
PN 12B113

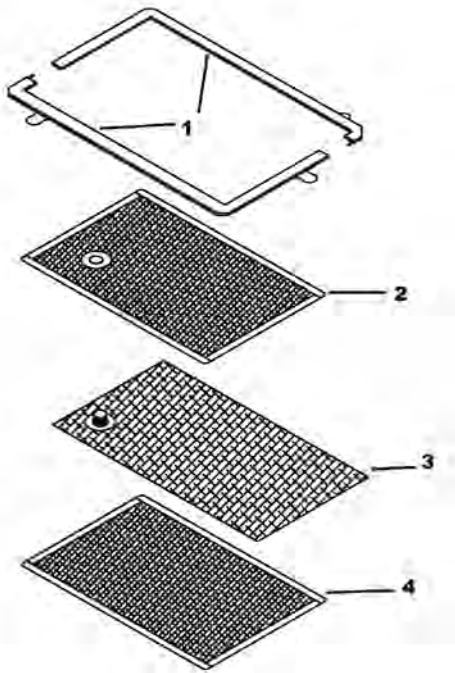

FILTER SCREEN ASSEMBLY		
ITEM	DESCRIPTION	PN
1	Replacement Frame Set	21A275
2	Replacement "Upper" Screen	21A285
3	Replacement Baffle Assembly	21A286
4	Replacement "Lower" Screen	21A287



STANDPIPE CLIP, BAFFLE AND MAGNEPAD ASSEMBLY PN 12B178		
ITEM	DESCRIPTION	PN
5	12" (13mm) Black Iron Close Nipple	24003
6	1" (10mm) x 7" (177.8mm) Black Iron Nipple	24470
7	2" (13mm) S/S Locking Seal Inline Plug	24A208
8	2" (13mm) Handle Assy With 90° Black Iron Elbow	19A598
11" x 18 4" (279mm x 464mm) Baffle Kit consists of items 9,10&11		29A058
9	Top Compression Cap (Knurl Knob)	24A153
10	11" (279mm) Standpipe Clip	29A052
11	9 a" x 16 d" (238mm x 429mm) Baffle	29A060
12	11" x 18 4" (279mm x 464mm) Filter Pad	29A059
Case of (PN 29A059) Filter Pads		29A057

* NOT SHOWN

**ULTRAFRYER MODEL PAR-3-HE GAS FRYER
AUTOMATIC VAT CLEANER
18" PN 12B493**

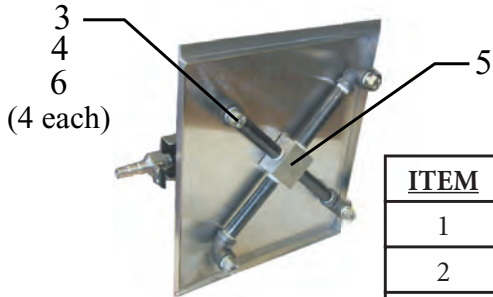
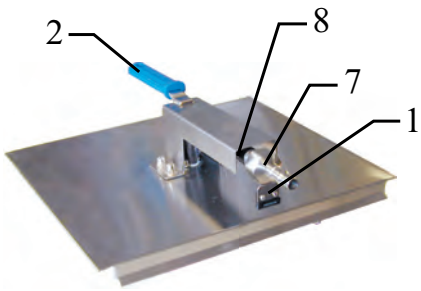

<u>ITEM</u>	<u>DESCRIPTION</u>	<u>PN</u>
1	Proximity Actuator Sensor	18A059
2	Cool II Handle	22734
3	½" (13mm) HH-2236 SQ Spray Nozzle	22A111
4	½" (13mm) x 90° Black Iron Elbow	24007
5	½" (13mm) 5 Way Black Iron Crossover Manifold	24A082
6	18" PAR-3-HE ½" (13mm) x 5 ¾" (146mm) Black Iron Nipple	24A100
7	½" (13mm) S/S Locking Seal Inline Plug	24A208
8	½" (13mm) x 6" (152mm) Black Iron Nipple	24A178

**ULTRAFRYER MODEL PAR-3-HE GAS FRYER
AUTOMATIC VAT CLEANER
18" PN 12B493**

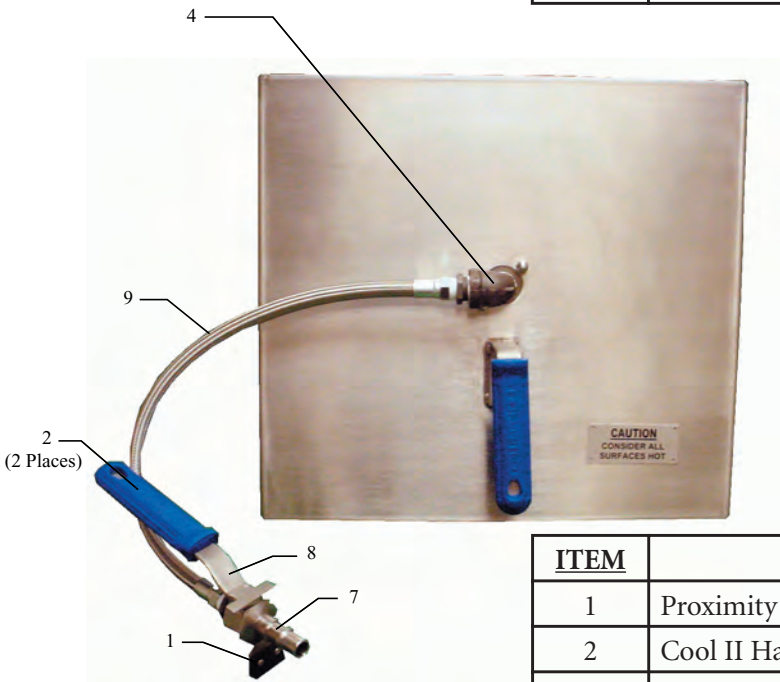

<u>ITEM</u>	<u>DESCRIPTION</u>	<u>PN</u>
1	Proximity Actuator Sensor	18A059
2	Cool II Handle	22734
4	½" (13mm) x 90° Black Iron Street Elbow	24256
7	Handle Assy, P3H Weld Coupling Male	19B242
8	½" (13mm) S/S Locking Seal In-Line Plug	24A208

WIRING DIAGRAMS

WIRING DIAGRAM - Since minor wiring changes may occur in the future, **USE** the diagram pasted to the fryer for circuit tracing and/or troubleshooting a Model PAR-3-HE Gas Fryer.

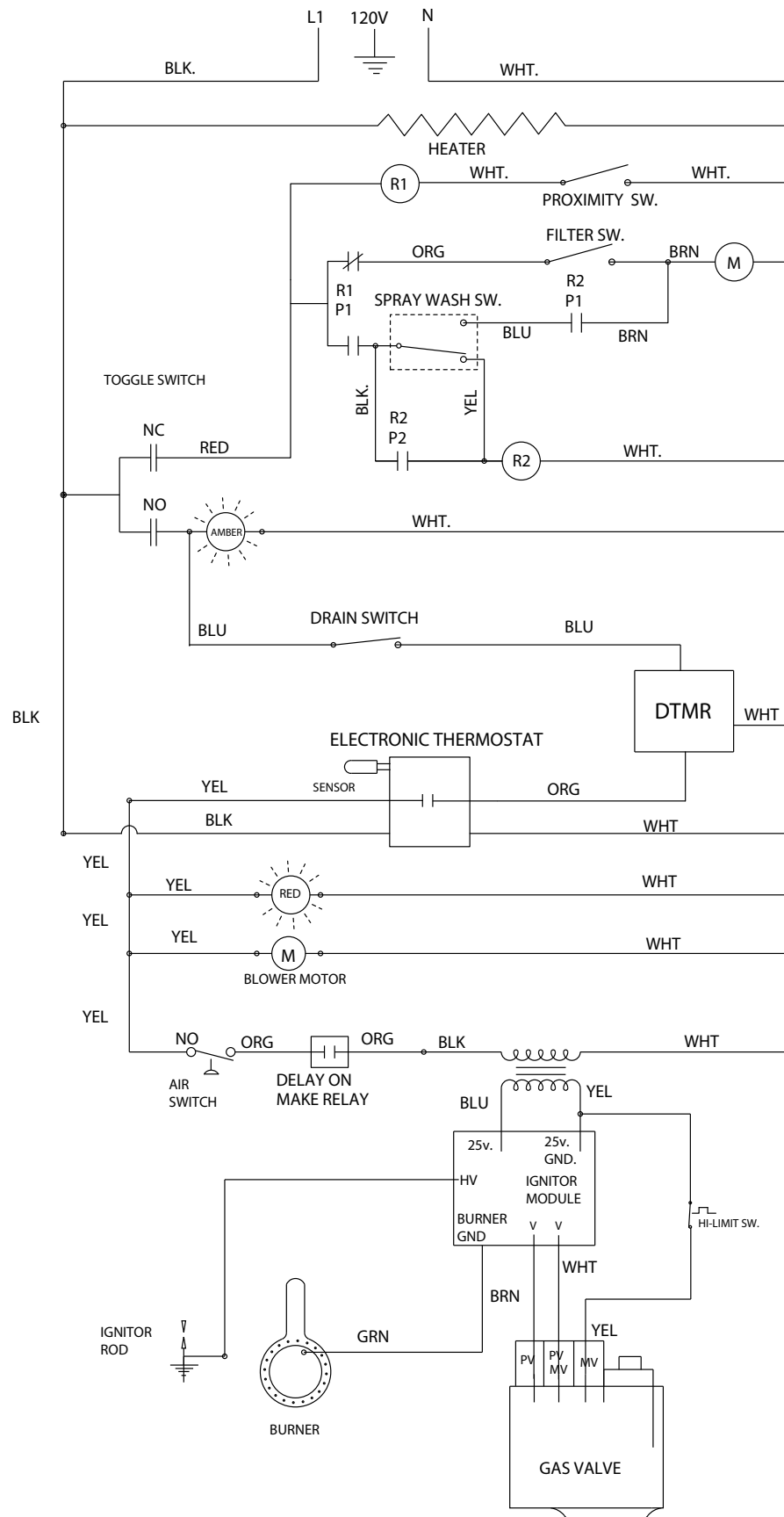

PAR-3-HE GAS FRYER W/ DTMR CONTROL

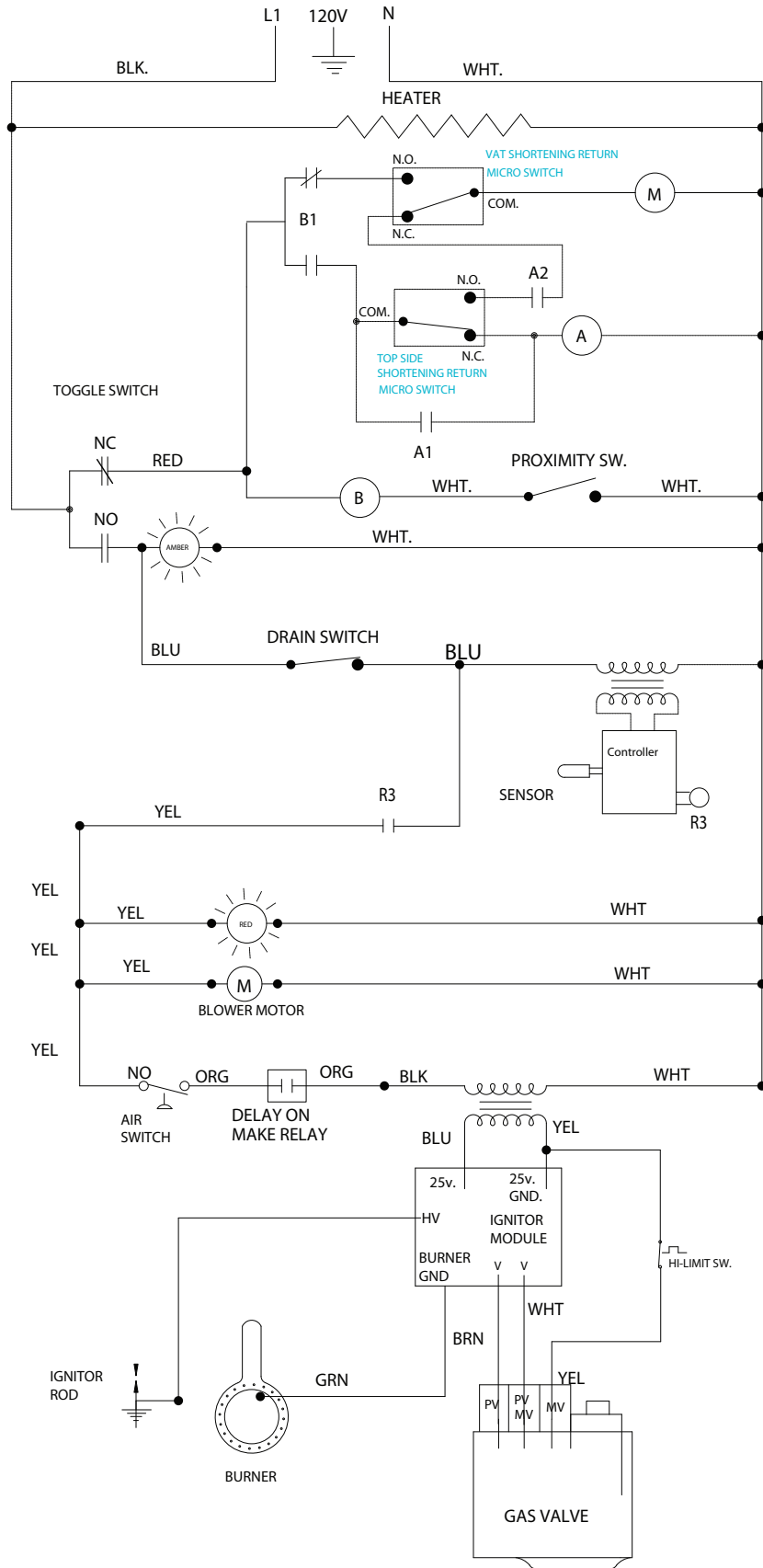

PAR-3-HE GAS FRYER W/ COMPUTER

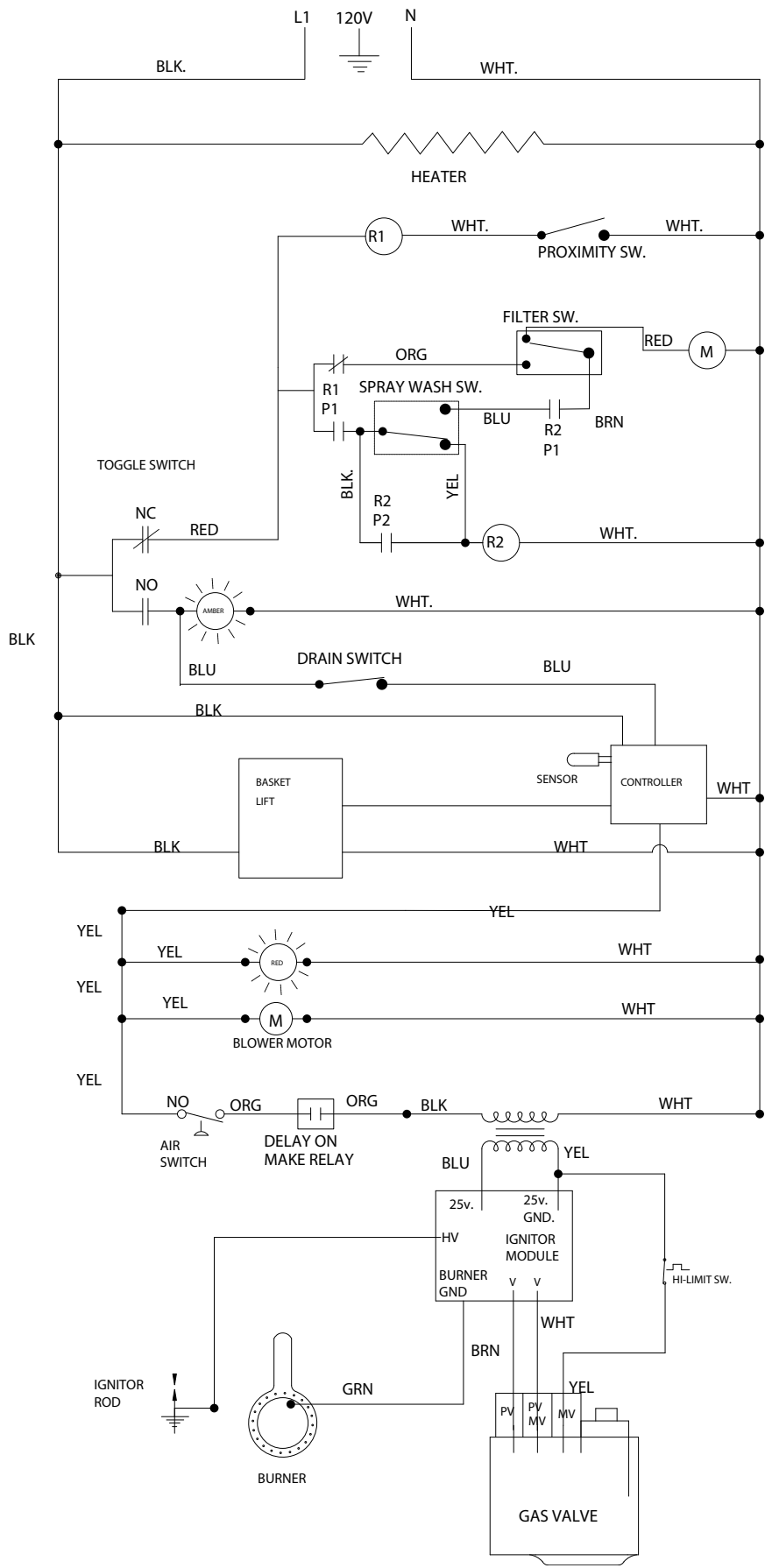

PAR-3-HE GAS FRYER W/ COMPUTER & BASKET LIFT

THIS PAGE INTENTIONALLY LEFT BLANK