



**ULTRAFRYER GAS FRYER  
MODEL F-P25-14 / 18 / 20 / 24  
OPERATION INSTRUCTIONS**



**FOR YOUR SAFETY**

Do not store or use gasoline or other flammable vapors or liquids in the vicinity of this or other appliance.

**WARNING**

Improper Installation, adjustment, alteration, service, or maintenance can cause property damage, injury, or death. Read the installation, operating, and maintenance instructions thoroughly before installing or servicing this equipment.

302 Spencer Lane • P.O. Box 5369

San Antonio, Texas 78201

(800) 525-8130 • (210) 731-5000 • Fax: (210) 731-5099

## PREFACE

This Manual was written and published by the Engineering Department, Ultrafryer Systems for use by personnel who will operate a Model P25 Gas Fryer in a commercial cooking environment.

**This appliance is intended for professional use and is to be operated by qualified personnel.**

Throughout this manual, NOTES, CAUTIONS, and WARNINGS are used to alert the operator to items of special circumstances. These items are identified as follows:

**NOTE:** Pull on the filter tub to ASSURE the male docking plug is SEATED in the female bulkhead socket.

**CAUTION:** To assure producing a quality product while prolonging the life expectancy of the fryer, ensure that the filtering, boil-out, and cleaning instructions are strictly followed.

**WARNING:** Do not allow any cleaning solution or water to splash into a vessel of hot cooking oil, as it will contaminate the oil and may cause the oil to splatter, causing severe burns.

*This manual is intended as a guide for all model PNP fryers, regardless of configuration, filtration options and controllers. It is to be used in conjunction with the applicable controller manual that is included with the fryer.*

**Retain this manual for future reference.**

**TABLE OF CONTENTS**

**GENERAL INFORMATION**

Warranty . . . . . 6  
Safety . . . . . 7  
Description / Specifications . . . . . 7  
Dimensions & Operational Requirements . . . . . 7  
Operating Controls Location . . . . . 8  
Operating Controls . . . . . 9  
Automatic Safety Features . . . . . 9  
Rating Plate . . . . . 9  
Inlet Gas Line Sizing . . . . . 10  
Inlet Gas Requirements . . . . . 10

**PRE-INSTALLATION**

General . . . . . 12  
Standards . . . . . 12  
Air Supply & Ventilation . . . . . 12

**RECEIVING & INSTALLING**

Unpacking . . . . . 14  
Installing . . . . . 14  
Leveling . . . . . 14  
Gas Connection . . . . . 15  
Electrical Connection . . . . . 15  
Cooking Computers . . . . . 16

**INITIAL START-UP**

Cleaning . . . . . 19  
Start-Up . . . . . 19  
Lighting Instructions . . . . . 19  
Sequence Of Ignition . . . . . 19  
Burner Operation Test . . . . . 19  
Test Start-Up . . . . . 19

**ABBREVIATED OPERATING INSTRUCTIONS**

General . . . . . 21  
Cooking . . . . . 21  
Filtering Shortening . . . . . 21  
Leveling Shortening . . . . . 21  
Boiling Out Fryer . . . . . 22  
Closing / Shutdown Instructions . . . . . 22

**TABLE OF CONTENTS.....Continued**

**PREVENTIVE MAINTENANCE & TROUBLESHOOTING**  
Preventive Maintenance ..... 24  
Troubleshooting ..... 24  
Troubleshooting Chart ..... 24

**CLEANING** ..... 27

**FILTER TUB ASSEMBLY & INSTALLATION**  
Filter Tub Assembly ..... 29  
Filter Tub Installation ..... 29

**TECHNICAL ASSISTANCE & ORDERING INFORMATION**  
Technical Assistance ..... 31  
Ordering Information ..... 31

**RECOMMENDED SPARE PARTS** ..... 33

**PARTS IDENTIFICATION**  
Parts Identification ..... 35

**WIRING DIAGRAMS** ..... 42

## GENERAL INFORMATION

## ULTRAFRYER<sup>®</sup> LIMITED WARRANTY: PAR-2

Ultrafryer Systems warrants to the original purchaser of a gas Ultrafryer<sup>®</sup> sold within the United States that it will be free of defects in material and workmanship for the periods listed below:

**STAINLESS STEEL FRYER VAT** – Stainless Steel fryer vats are warranted for (10) ten years upon the terms hereinafter described. The (10) ten year warranty coverage applies ONLY to the Stainless Steel fryer vat and does not apply to the other components such as controls, fire boxes, gaskets, mounting hardware, or the heat shield weldment. The (10) ten year limited warranty coverage for the Stainless Steel fryer vats are as follows: (1) Vats that fail due to faulty workmanship or materials within the first twelve (12) months from the date of initial start up will be exchanged at no cost. Standard delivery ground freight will be prepaid by Ultrafryer Systems for **first year failures only**. The cost of labor to install the replacement vat will be covered by Ultrafryer Systems for vats, which fail within twelve (12) months from the date of initial start up. Labor for vat replacements after the first year is the responsibility of the owner. (2) Vats that fail within the second through fifth year will be exchanged at \$250.00 FOB San Antonio. (3) Vats that fail within the sixth through eighth year will be exchanged at 50% of current selling price of said vat FOB San Antonio. (4) Vats that fail within the ninth through tenth year will be exchanged at 70% of the current selling price of said vat FOB San Antonio. (**Example:** If the current selling price for a particular vat is \$2,000.00, then a failure during the sixth through eighth year would be exchanged for \$1,000.00; if the failure occurred in the ninth or tenth year it would be exchanged for \$1,400.00.) Proper credit issue for vat failures is contingent upon receipt, by Ultrafryer Systems, of the serial number identification tag for any failed vat.

**ULTRAFRYER PARTS** – All parts on the Ultrafryer<sup>®</sup> are covered for a period of one (1) year from the initial date of start up. This is to include gas valves, switches, thermostats, etc. Ultrafryer Systems reserves the right to charge for certain parts such as computers, filter pumps and motors or any item over the amount of \$100.00 until Ultrafryer Systems receives the defective part back. **After inspection, credit for the part will be issued to the purchaser provided the part is deemed defective and that defect is not the result of neglect or abuse by the user.** The shortening filtration system, (hoses) are warranted for ninety (90) days from the initial date of start up.

**PROCESSING WARRANTY CLAIMS** – The equipment owner must promptly notify Ultrafryer Systems Warranty Department of any alleged defects as soon as they are discovered by calling 1-800-525-8130. After such notice, the Warranty Department will perform its obligation under this warranty within a commercially reasonable period of time. If alleged defects develop after normal business hours, on weekends or on holidays the owner must call Ultrafryer Systems first at the above number. This number is monitored 24 hours a day, 7 days a week. Ultrafryer Systems will notify an authorized service agent to make repairs during normal hours or after hours. Any parts that need to be shipped back to Ultrafryer Systems will be shipped back **prepaid by the customer** marked with the processing number and to the attention of the WARRANTY DEPARTMENT.

**NON WARRANTY COVERAGE** – This warranty does not include coverage for any consequential cost of damages including, but not limited to, any loss in store sales, spoiled food products, transportation, duty or custom cost. This warranty does not cover the Ultrafryer<sup>®</sup> exported to countries outside the United States and its territories. This warranty does not cover original installation and adjustments such as leveling, calibrations and electrical and gas connections. This warranty does not cover travel over 100 miles or 2 hours driving time from the location of the Ultrafryer<sup>®</sup> or overtime or holiday charges unless the Warranty Department granted prior approval. This warranty does not cover damage due to misuse, abuse, alteration or accident. This Warranty does not cover improper or unauthorized repair or installation, damage in shipment, normal maintenance items such as gaskets, hoses, and exterior finishes. Ultrafryer Systems will begin the fryer warranty one week after shipment but will adjust the warranty upon receiving approved documentation. We reserve the right to void component part warranty on any Ultrafryer that is stored more than six (6) months after shipment from Ultrafryer Systems and not put into service.

**LABOR COVERAGE** – The cost for labor to replace parts are covered for one (1) year after the initial start up. **The Warranty Department must be promptly notified of any defects within the first year of operation.** The labor warranty does not include the cost to repair or clear dirty filter systems or perform any adjustments that would normally fall under the tasks associated with a proper start up and/or demonstration. **Labor is covered by Ultrafryer Systems for repairs by an AUTHORIZED service agent.** Owner is responsible for all costs associated with fryer installation and start up unless prior arrangements have been made with Ultrafryer Systems.

### DISCLAIMER OF WARRANTIES

Other than as stated herein, ULTRAFRYER SYSTEMS makes no warranty of any kind, express or implied, including but not limited to any warranty of merchantability of fitness for a particular purpose, including trade usage. Ultrafryer Systems' sole obligation, and purchaser's sole remedy, under this warranty is repair or replacement, at the discretion of Ultrafryer Systems, of any part or component that proves to be defective in materials or workmanship. In no event shall Ultrafryer Systems be liable for consequential, incidental, or special loss or damages arising from the use of, or inability to use, the ULTRAFRYER<sup>®</sup>. This limited warranty is the only and complete statement with respect to warranties of NEW Ultrafryer<sup>®</sup> PAR-2, Gas ULTRAFRYERS<sup>®</sup> sold after June 1<sup>st</sup>, 2000. There are no other documents or oral statements for which Ultrafryer Systems will be responsible. Effective 2-1-2008.

**B. SAFETY**

The major safety concern associated with the Ultrafryer Gas Fryer is burns from hot shortening. In order to prevent serious burns, good housekeeping habits are required. The floor in front of and the area around the fryer should be kept clean and dry. Whenever anything is placed in to a fryer vat, care should be used not to splash the hot shortening. Product should always be “**PLACED**” into the shortening, **NOT THROWN**. Safety goggles, neoprene insulated gloves and an apron must be worn while filtering or boiling-out a fryer vat. Electrical controls on all Ultrafryer Fryers operate on 120 volts single phase electrical power. No adjustments or replacement of electrical controls should ever be attempted without first disconnecting electrical power. The fryer should never be operated with wet hands or while standing in water. To do so can result in serious electrical shock or death.

**C. DESCRIPTION / SPECIFICATIONS**

The Ultrafryer Gas Fryer is constructed from 16 & 18 gauge, “300” series, polished, satin finish stainless steel. Most Models are equipped with a Default-To-Manual-Restart (DTMR) Control or an Ultrastat 11 Cooking Computer; however, customers may request the fryer be equipped with an Ultrastat 21 or Ultrastat 25 Cooking Computer. In addition, the Model PAR25 can be equipped with the EZ Dock Filtration System, which uses a stainless steel Filter Screen. The Customer has the option of ordering a Filter Pad Assembly that uses an impregnated Filter Pad in lieu of the S/S filter screen. The dimensions and gas rating of the Model PAR25 Gas Fryer are as follows:

**D. ULTRAFRYER MODEL PAR3/PAR25 GAS FRYER DIMENSIONS & OPERATIONAL REQUIREMENTS**

	<u>14" VAT</u>		<u>18" VAT</u>		<u>20" VAT</u>		<u>24" VAT</u>	
Overall Width	15.625 in	397 mm	19.625 in	498 mm	21.625 in	549 mm	25.625 in	651 mm
Overall Depth	30.75 in	781 mm	30.75 in	781 mm	30.75 in	781 mm	30.75 in	781 mm
Work Height	35.75 in	908 mm	35.75 in	908 mm	35.75 in	908 mm	35.75 in	908 mm
Oil Capacity - High Level	45 Lb	20.4 kg	75 Lb	34 kg	98 Lb	44.4 kg	120 Lb	54.4 kg
Oil Capacity - Low Level	35 Lb	15.9 kg	75 Lb	34 kg	98 Lb	44.4 kg	120 Lb	54.4 kg
<b>Gas Rating</b>								
Butane	70,000 BTU/hr	73.9 MJ/hr	80,000 BTU/hr	84.4 MJ/hr	70,000 BTU/hr	73.9 MJ/hr	80,000 BTU/hr	84.4 MJ/hr
Natural	80,000 BTU/hr	84.4 MJ/hr	85,000 BTU/hr	89.7 MJ/hr	80,000 BTU/hr	84.4 MJ/hr	85,000 BTU/hr	89.7 MJ/hr
Propane	80,000 BTU/hr	84.4 MJ/hr	85,000 BTU/hr	89.7 MJ/hr	80,000 BTU/hr	84.4 MJ/hr	85,000 BTU/hr	89.7 MJ/hr
<b>Orifice Drill Size</b>								
Butane	#42		2.7 mm		#42		2.7 mm	
Natural	#20		#18		#20		#18	
Propane	#38		#33		#38		#33	
<b>Gas Valve Pressure</b>								
Butane (W.C.)	10" w.c.	254 mm	10" w.c.	254 mm	10" w.c.	254mm	10" w.c.	254mm
Natural (W.C.)	4" w.c.	102 mm	4" w.c.	102 mm	4" w.c.	102mm	4" w.c.	102mm
Propane (W.C.)	10" w.c.	254 mm	10" w.c.	254 mm	10" w.c.	254mm	10" w.c.	254mm
<b>Inlet flow Required at STP</b>								
Butane	22 ft <sup>3</sup> /hr	0.62 m <sup>3</sup> /hr	25 ft <sup>3</sup> /hr	0.71 m <sup>3</sup> /hr	22 ft <sup>3</sup> /hr	0.62 m <sup>3</sup> /hr	25 ft <sup>3</sup> /hr	0.71 m <sup>3</sup> /hr
Natural	80 ft <sup>3</sup> /hr	2.27 m <sup>3</sup> /hr	85 ft <sup>3</sup> /hr	2.40 m <sup>3</sup> /hr	80 ft <sup>3</sup> /hr	2.27 m <sup>3</sup> /hr	85 ft <sup>3</sup> /hr	2.40 m <sup>3</sup> /hr
Propane	32 ft <sup>3</sup> /hr	0.91 m <sup>3</sup> /hr	34 ft <sup>3</sup> /hr	0.96 m <sup>3</sup> /hr	32 ft <sup>3</sup> /hr	0.91 m <sup>3</sup> /hr	34 ft <sup>3</sup> /hr	0.96 m <sup>3</sup> /hr
<b>Shipping Cube</b>								
Shipping Cube	10 ft <sup>3</sup>	3.05 m <sup>3</sup>	12 ft <sup>3</sup>	3.66 m <sup>3</sup>	14 ft <sup>3</sup>	4.27 m <sup>3</sup>	16 ft <sup>3</sup>	4.88 m <sup>3</sup>
<b>Shipping Weight</b>								
Shipping Weight	165 Lb	74 kg	170 Lb	77 kg	177 Lb	80 kg	250 Lb	113 kg
<b>Power Input</b>								
All units use 120Volt 6 amp 60 Hz 1 O								

NOTE:

CONSULT THE INCLUDED COMPUTER CONTROLLER MANUAL AND FILTRATION MANUAL FOR TEST START-UP, OPERATIONS, COOKING, FILTERING, AND BOIL OUT PROCEDURES.

E. OPERATING CONTROLS LOCATION

MODEL PAR25  
GAS FRYER

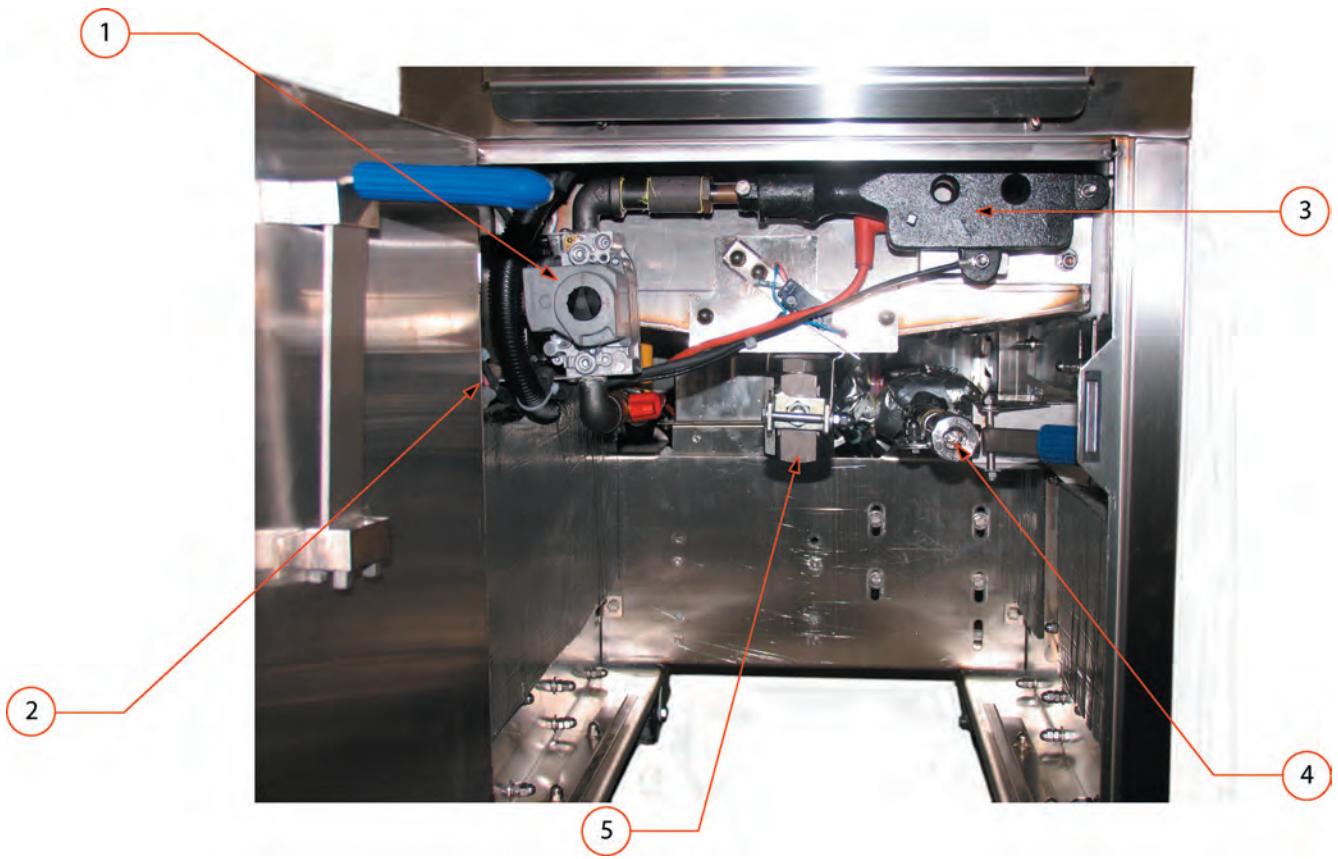

1	Gas Regulator and Shutoff Valve
2	High Limit
3	Burner
4	Docking Connection
5	Main Drain Valve

## MODEL PAR25 GAS FRYER

### F. OPERATING CONTROLS:

The “basic” PAR25 gas fryer is equipped with an Electronic Thermostat and Default-to-Manual-Restart (DTMR) control; however, customers may request the fryer be equipped with an “optional” Ultrastat Cooking Computer, such as an Ultrastat 11,21 or 25 Cooking Computer. When applicable, operating instructions for the Ultrastat Cooking Computer will be provided with the fryer. Operating controls on the Model PAR25 gas fryer include the Toggle **HEAT/OFF** Switch, **AMBER** Power Indicator Lamp, **RED** Burner Indicator Lamp, and the applicable Temperature Controller. These controls are mounted on the Temperature Control Access Panel; and the Electronic Thermostat and other fryer controls are located behind the access door. The main drain valve and (if applicable) shortening return levers are located behind the Service Access Panel.



Figure (from left to right): 18” Model Par25 and 24” Model Par25

### G. AUTOMATIC SAFETY FEATURES:

1. High limit thermostat to shut off gas to the main burners by opening a solenoid-actuated safety valve in the combination gas control valve.
2. Combination gas control valve which includes a built-in pressure regulator and manual valve.
3. Sensing circuit within the spark ignitor module to turn gas to the fryer **OFF** if a burner **FLAME OUT** occurs.
4. A Drain Valve Safety Switch and a Default-to-Off circuit in the Default-to-Manual-Restart (DTMR) Control that will **DISABLE** the fryer each time the drain valve is **OPENED**.
5. An **AIR PRESSURE** switch to open the electrical circuit to the spark ignitor and gas valve which will turn the gas to the fryer **OFF** in the event the blower motor fails.

### H. RATING PLATE:

Information on this plate includes the model and serial number; BTU/HR input rating of the burners; gas manifold pressure in inches W.C. ; minimum inlet gas required, orifice size; and type of gas. This data is essential for proper identification when communicating with ULTRAFRYER SYSTEMS or requesting special parts or information. The rating plate is located on the inside of the Service Access door.

**THE FRYER MUST BE CONNECTED ONLY TO THE TYPE OF GAS IDENTIFIED ON THIS RATING PLATE!**

## I. INLET GAS LINE SIZING:

The Table below is used to calculate the size (diameter) of the inlet gas line from the building regulator to the fryer manifold.

INLET GAS LINE REQUIREMENTS									
PIPE LENGTH	PIPE DIAMETERS (inches & (mm equivalents))								
	Maximum Allowable Flow (Shown in ft <sup>3</sup> /hr (M <sup>3</sup> /hr))								
Feet (Meters)	½" (13 mm)	¾" (19mm)	1" (25mm)	1¼" (32mm)	1½" (38mm)	2" (51mm)	2½" (64mm)	3" (76mm)	4" (102mm)
15 (4.6)	62 (1.7)	170 (4.7)	350 (9.8)	620 (17.4)	960 (26.9)	2,000 (56.0)	3,500 (98.0)	5,400 (151.2)	11,200 (313.6)
30 (9.1)	43 (1.2)	120 (3.4)	245 (6.9)	430 (12.0)	680 (19.0)	1,400 (39.2)	2,450 (68.6)	3,800 (106.4)	7,900 (221.2)
45 (13.7)	35 (1.0)	98 (2.7)	200 (5.6)	355 (9.9)	530 (14.8)	1,150 (32.2)	2,000 (56.0)	3,200 (89.6)	7,900 (182.0)
60 (18.3)	30 (0.8)	84 (2.4)	175 (4.9)	310 (8.7)	480 (13.4)	1,000 (28.0)	1,760 (49.3)	2,700 (75.6)	5,600 (156.8)
75 (22.9)	27 (0.8)	76 (2.1)	155 (4.3)	275 (7.7)	430 (12.0)	890 (24.9)	1,560 (43.7)	2,450 (68.6)	5,000 (140.0)
90 (27.4)	25 (0.7)	70 (2.0)	145 (4.1)	250 (7.0)	395 (11.1)	810 (22.7)	1,430 (40.0)	2,260 (63.3)	4,550 (127.4)
105 (32.0)	23 (0.6)	64 (1.8)	132 (3.7)	232 (6.5)	370 (10.4)	750 (21.0)	1,300 (36.4)	2,100 (58.8)	4,200 (117.6)
120 (36.6)	21 (0.6)	60 (1.7)	125 (3.5)	215 (6.0)	340 (9.5)	700 (19.6)	1,200 (33.6)	1,950 (54.6)	4,000 (112.0)
150 (45.7)	19 (0.5)	54 (1.5)	110 (3.1)	195 (5.5)	310 (8.7)	630 (17.6)	1,080 (30.2)	1,750 (49.0)	3,550 (99.4)
180 (54.9)	17 (0.5)	49 (1.4)	100 (2.8)	175 (4.9)	280 (7.8)	570 (16.0)	960 (26.9)	1,600 (44.8)	3,200 (89.6)
210 (64.0)	16 (0.4)	44 (1.2)	94 (2.6)	165 (4.6)	260 (7.3)	530 (14.8)	890 (24.9)	1,450 (40.6)	3,000 (84.0)
240 (73.2)	15 (0.4)	43 (1.2)	88 (2.5)	155 (4.3)	240 (6.7)	500 (14.0)	840 (23.5)	1,350 (37.8)	2,800 (78.4)
270 (82.3)	14 (0.4)	40 (1.1)	83 (2.3)	145 (4.1)	230 (6.4)	470 (13.2)	780 (21.8)	1,300 (36.4)	2,650 (74.2)
300 (91.4)	14 (0.4)	38 (1.1)	79 (2.2)	138 (3.9)	215 (6.0)	440 (12.3)	750 (21.0)	1,250 (35.0)	2,500 (70.0)
450 (137.2)	11 (0.3)	31 (0.9)	64 (1.8)	112 (3.1)	176 (4.9)	360 (10.1)	630 (17.6)	1,000 (28.0)	2,050 (57.4)
600 (182.9)	10 (0.3)	27 (0.8)	56 (1.6)	97 (2.7)	152 (4.3)	315 (8.8)	530 (14.8)	860 (24.1)	1,750 (49.0)

- NOTE: 1) FT<sup>3</sup>/HR (M<sup>3</sup>/HR) values may vary due to heating value and specific gravity of gas supplied by local companies.  
 2) To determine the inlet gas line diameter for the distance between the fryer and main gas regulator, locate the FT<sup>3</sup>/HR (M<sup>3</sup>/HR) of gas required for the fryer and pipe length and read the pipe diameter on the top row. For example: a PAR25 fryer operating on NATURAL GAS requires 90 FT<sup>3</sup>/HR (2.5 M<sup>3</sup>/HR) of gas at the fryer's inlet gas manifold. If the fryer bank is located 60 feet from the building gas regulator, a 1" (25mm) diameter gas line MUST be installed between the manifold and regulator.

## J. GAS LINES

The Flexible Gas Line used to connect the gas manifold to the building gas supply line must be rated for the BTU/Hr (MJ/Hr) designated for the Fryer. Flexible gas lines and their ratings stocked by Ultrafryer Systems are listed below:

FLEXIBLE GAS LINES STOCKED BY ULTRAFRYER SYSTEMS		
NUMBER	DESCRIPTION	RATING BTU/HR (MJ/HR)
24322	3/4" (19mm) Diameter Flexible Gas Line (w/quick connect couplings) 48" (1219mm) long. Connect-It SSGC75-48-UCQ	225,000 (238)
24323	1" (25mm) Diameter Flexible Gas Line (w/quick connect couplings) 48" (1219mm) long. Connect-It SSGC100-48-UCQ	435,000 (459)
24456	1 1/4" (32mm) Diameter Flexible Gas Line (w/quick connect couplings) 48" (1219mm) long. Connect-It SSGC125-48-UCQ	875,000 (924)

## PRE-INSTALLATION

- A. GENERAL:** Safe and satisfactory operation of a Model PAR25 gas fryer depends on its proper installation. Installation must conform to local codes or, in the absence of local codes, with the current National Fuel Gas Code ANSI Z223.1 (latest edition). In Canada, gas installation shall be in accordance with the current CAN/CGA B 149.1 and .2 installation codes and/or local codes. Each Model PAR25 fryer should be installed as follows:
1. Placed beneath a properly designed exhaust hood
  2. Installed by a licensed plumber.
  3. Connected to the type gas for which the unit was fabricated as shown on the rating plate.
  4. Connected to the proper size pressure regulator installed in the gas supply line and adjusted to the proper manifold pressure.
  5. Connected to the main gas supply line with the proper size supply line.
  6. Restrained by use of a restraining device to avoid splashing of hot liquid and to assure tension cannot be placed on the flexible gas line or fittings.

**CLEARANCES:** The appliance must be kept free and clear of all combustibles. The minimum clearance from combustible and non-combustible construction is 6" (152 mm) from the sides, and 6" (152 mm) from rear. The fryer may be installed on combustible floors.

**NOTE:** Adequate clearances must be provided for servicing and proper operation.

- B. STANDARDS:** Installation must be planned in accordance with all applicable state and local codes, taking into account the following standards:
1. The fryer and its individual shut-off valve must be disconnected from the gas supply piping system during any pressure testing of that system at pressures in excess of ½ psig (3.45kPa). In Canada, gas installation shall be in accordance with the current CAN/CGA B 149.1 and .2 installation codes and/or local codes.
  2. The fryer must be isolated from the gas supply piping system by closing its individual manual shut-off valve during any pressure testing of the gas supply piping system at pressures equal to or less than ½ psig (3.45kPa).
  3. When installed the fryer must be electrically grounded in accordance with local codes, or in the absence of local codes, in accordance with the current National Electrical code ANSI/NFPA 70 (latest edition). In Canada electrical installation must be in accordance with the current CSA C22.1 Canadian Electrical Code and/or local codes.
  4. Other applicable nationally recognized installation standards such as:
    - a. National Fuel Gas Code ANSI Z223.1 (latest edition)  
American Gas Association  
1515 Wilson Blvd.  
Arlington, VA22209
    - b. NFPA Standards #54, #94 and #221 (latest edition)  
National Fire Protection Association  
470 Atlantic Avenue  
Boston, MA 02110
    - c. ANSI Z21.69/CAN/CGA-6.16 AND Z21.41/CAN1 6.9
  5. Exhaust vent hood, when installed must conform to the current NFPA 54-1 and Canadian CAN/CGA-1.11 (latest edition)

**NOTE:** Local building codes will usually not permit a fryer with its open tank of hot oil to be installed immediately next to an open flame of any type, whether a broiler or an open burner or range. Check local codes before beginning installation.

- C. AIR SUPPLY AND VENTILATION:** The area around the appliance must be kept clear of any combustible or flammable products and avoid any obstruction to the flow of ventilation air as well as for ease of maintenance and service. **NOTHING** is to be stored in the interior of the fryer's cabinet except the filter tub assembly.
1. A means must be provided for any commercial, heavy duty-cooking appliance to exhaust combustion wastes outside of the building. It is essential that a fryer be set under a powered exhaust vent hood or that an exhaust fan be provided in the wall above the unit, as exhaust temperatures are in the vicinity of 400°F (204°C).

**NOTE:** Strong exhaust fans in a hood or in the overall air conditioning system can produce slight air drafts in the room, which can interfere with burner performance and be hard to diagnose. Air movement should be checked during installation and if burner problems persist, make-up air openings or baffles may have to be provided in the room.

2. Exhaust temperature, in addition to the open tank of hot oil, make the storage of anything on shelving over or behind the fryer unsafe.
3. Filters and drip troughs should be part of any industrial hood, but consult local codes before constructing and installing any hood.
4. Provisions must be made for an adequate supply of fresh air and adequate clearance must be maintained for air openings into the combustion chamber.

## RECEIVING & INSTALLING

- A. **UNPACKING:** Check that the container is upright. Use an outward prying motion – **DO NOT USE A HAMMER** - to remove the carton. Check the fryer for visible damage; if such damage has occurred do not refuse shipment, but contact the carrier and file the appropriate freight claims.
- B. **INSTALLING:** Roll the assembled fryer into the building, to its operating location.

**WARNING: IMPROPER INSTALLATION, ADJUSTMENT, ALTERATION, SERVICE OR MAINTENANCE CAN CAUSE PROPERTY DAMAGE, INJURY OR DEATH. READ THE INSTALLATION, OPERATING AND MAINTENANCE INSTRUCTIONS THOROUGHLY BEFORE INSTALLING OR SERVICING THIS EQUIPMENT.**

C. **LEVELING:**

1. When the fryer is placed in its operating location check to be sure it is level. If not, loosen the casters and insert the appropriate number of shim plates between leg and caster plates then retighten the caster bolts.
2. If the floor is smooth and level, adjust to the high corner and measure with a spirit level. If the floor is uneven or has a decided slope, level the unit with metal shims.

**NOTE:** A caster may not return exactly to the same position after being moved, which may require re-leveling after each move.

3. Connect the gas manifold to the building gas supply line by means of a CSA International APPROVED flexible gas line as shown in the figure below.

**NOTE:** CONNECT-IT inc. ¾" (19mm), 1" (25mm) and 1 ¼" (32mm) flexible gas hose 4 feet long (1219mm) with a quick disconnect coupling on one end is available from Ultrafryer Systems under PN 24322 (¾" (19mm) hose), PN 24323 (1" (25mm) hose) and PN 24456 (1 ¼" (32mm) hose). These hoses are equipped with a fusible link, which melts at 361°F (183°C) that will **SHUT OFF** the gas supply when it melts. A 44" (1119mm) long restraining device is also available under PN 24324.

**CAUTION: THE BUILDING GAS SUPPLY LINE MUST BE SIZED TO PROVIDE THE VOLUME OF GAS REQUIRED FOR PROPER OPERATION AS EXPLAINED ON THE PREVIOUS PAGE.**

TYPICAL GAS CONNECTION

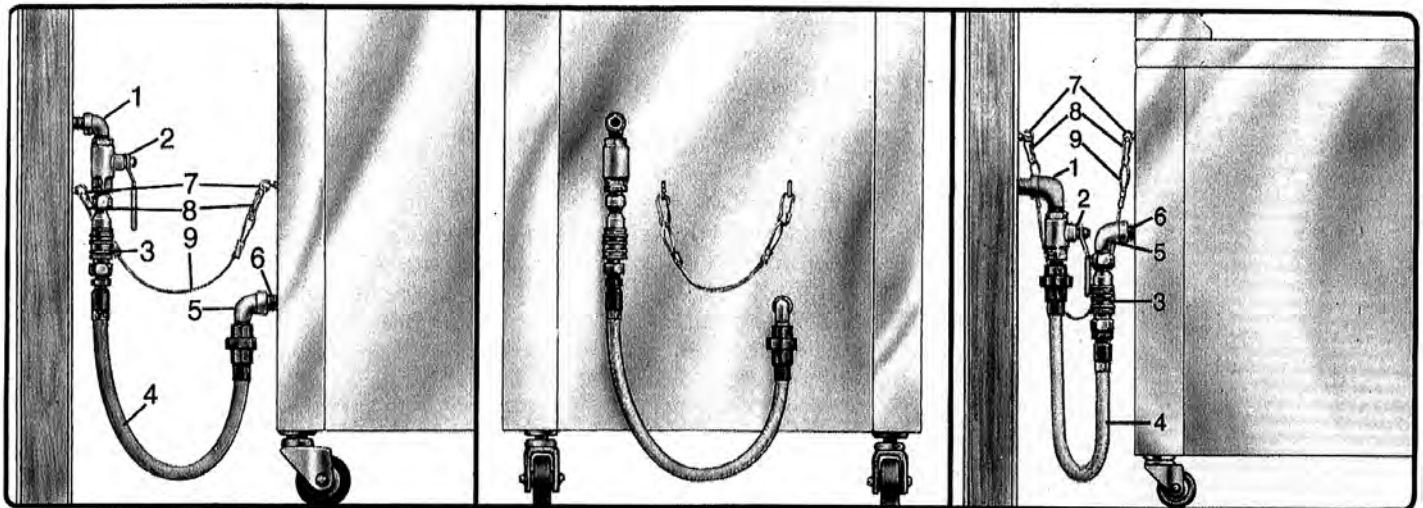

**WARNING: THE RESTRAINT DEVICE (ITEM 9) MUST BE INSTALLED TO PREVENT TIPPING AND / OR SPLASHING OF HOT LIQUID AND TO ASSURE TENSION CANNOT BE PLACED ON THE FLEXIBLE GAS LINE OR FITTING.**

- |  |   |
|--|---|
| <ol style="list-style-type: none"> <li>1. BUILDING GAS SERVICE LINE</li> <li>2. MAIN GAS CUT-OFF VALVE</li> <li>3. CONNECT-IT QUICK-DISCONNECT</li> <li>4. FLEX-CON CONNECTOR</li> <li>5. ELBOW</li> </ol> | <ol style="list-style-type: none"> <li>6. APPLIANCE MANIFOLD/NIPPLE</li> <li>7. EYELET FASTENERS</li> <li>8. SPRING HOOK</li> <li>9. RESTRAINING CHAIN</li> </ol> |
|--|---|

- D. GAS CONNECTION:** The gas supply (service) line must be the same size or greater than the inlet line of the appliance. **THE GAS SUPPLY LINES MUST BE SIZED TO ACCOMMODATE ALL THE GAS FIRED EQUIPMENT THAT MAY BE CONNECTED TO THAT SUPPLY.** Refer to the Inlet Gas Line Sizing Table and inlet gas requirements.

**NOTE:** Sealant used on all pipe joints must be resistive to butane and propane gas.

1. Manual shut off valve: This supplier-installed valve must be installed in the gas service line ahead of the appliance and in a position where it can be reached quickly in the event of an emergency.
2. Pressure regulator: All commercial cooking equipment must have a pressure regulator on the incoming service line for safe and efficient operation, because service pressure may fluctuate with local demand. External regulators are not required on this fryer, as that function is performed by a combination gas control valve, however if the incoming pressure is in excess of ½ psig, a step-down regulator will be required.
3. Natural gas: Natural gas fryers require 7" (178mm) water column (W.C.) "inlet" pressure to the fryer's combination gas control valve for proper operation, when all gas units are operating simultaneously. Butane and Propane gas fryers require 14" (356mm) water column (W.C.) "inlet" pressure to the fryer's combination gas control valve for proper operation, when all gas units are operating simultaneously. This "inlet" pressure **MUST** be checked with a manometer **PRIOR** to placing the fryer in operation.

**WARNING: IF THE "INLET" GAS PRESSURE AT THE FRYER'S COMBINATION GAS CONTROL VALVE "EXCEEDS" ½ lb/in<sup>2</sup> (.035 kg/cm<sup>2</sup>) OR APPROXIMATELY 14" (356 mm) W.C., AN EXTERNAL REGULATOR MAY BE NEEDED TO PREVENT DAMAGE TO THE COMBINATION GAS VALVE, AND VOIDING OF WARRANTY. FAILURE TO ADDRESS THIS COULD RESULT IN AN EXPLOSION OR A FIRE.**

4. Combination gas control valve: The correct combination gas control valve and orifice is installed at the factory for **BUTANE, NATURAL** and **PROPANE** units based on each Purchase Order. This valve should be **CHECKED/ADJUSTED** by qualified service personnel using proper test equipment for the following "**OUTLET**" gas pressure **PRIOR** to start-up of a fryer. **NATURAL GAS FRYERS 4" (102mm) W.C. BUTANE/PROPANE FRYERS 10" (254mm) W.C.**
  5. Rigid connections: Check any installer-supplied intake pipe(s) visually and/or blow them out with compressed air to clear dirt particles, threading chips or any other foreign matter before connecting to the service line as these particles may clog the orifice when gas pressure is applied. All connections must be tested with a soapy solution before lighting the fryer. **DO NOT USE AN OPEN FLAME TO CHECK FOR LEAKS!** Putting an open flame beside a new connection is not only dangerous, but will often miss small leaks that a soapy solution would find.
  6. Flexible Couplings, Connectors: The installation is to be made with a connector that (1) complies with the **Standard for Connectors for Movable Gas Appliances, ANSI Z21.69 (CAN/CGA-6.16)**, and a quick-disconnect device that complies with the **Standard for Quick-Dis-connect Devices for Use With Gas Fuel, ANSI Z21.41 (CAN1-6.9)** (2) adequate means must be provided to limit the movement of the appliance without depending on the connector and the quick dis-connect device or its associated piping to limit the appliance movement and (3) the location(s) where the restraining means may be attached to the appliance shall be specified. **DOMESTIC CONNECTORS ARE NOT SUITABLE!!!**
  7. Fryer Service: The fryer is equipped with swivel casters. To service the fryer:
    - a) Turn "OFF" gas supply at the supply source.
    - b) Disconnect the flexible gas line quick-disconnect
    - c) Disconnect restraint means and roll fryer out for rear service access.
    - d) When the fryer is re-positioned, be sure to reconnect the restraint and level the fryer.
- E. ELECTRICAL CONNECTION:** The MAXIMUM current draw per vat at Initial Start-up or during a Warm-up Cycle will be 3 Amperes at 120 Volts. When running the Filter System simultaneously allow for an additional 3 Amperes. Refer to the wiring diagram attached to the inside of the Service Access door for internal electrical connections.

## F. Cooking Computers

All fryers from Ultrafryer are shipped with the applicable manual for the cooking computer or computers that are specific to that fryer. The following list shows the cooking computer types and their related manuals.

**NOTE:** The appearance of a given cooking computer's control panel may vary slightly depending upon the style of fryer on which the computer is installed. This does not affect the actual operation of the computer. Please refer to the pertinent cooking computer manual for more information.

U03 / DTMR Cooking Computer (refer to Manual P/N 30A192; French Version 30A192 FR)

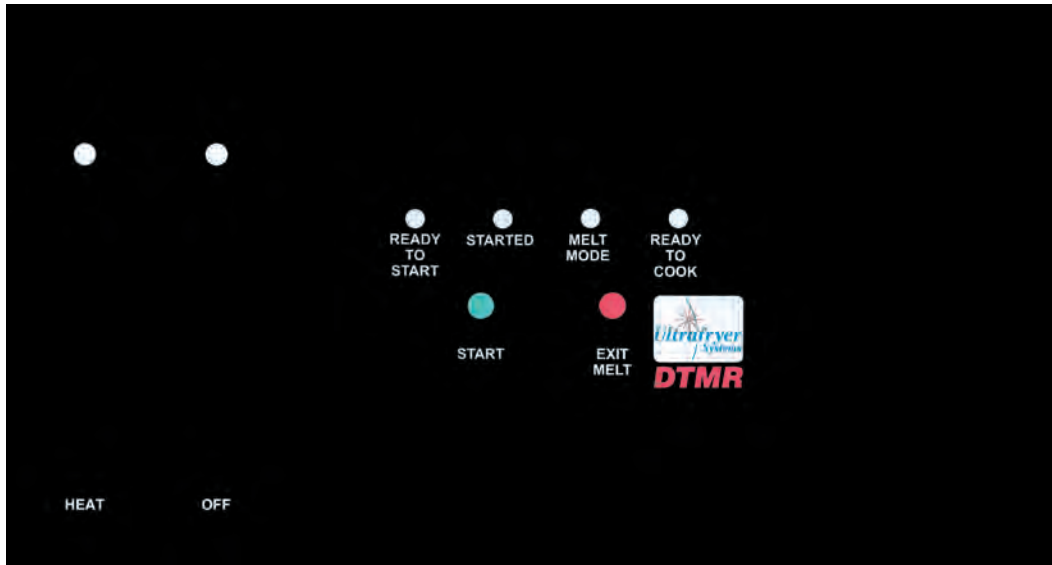

Ultrastat 25 Cooking Computer (refer to Manual P/N 30A190; French Version 30A190 FR)

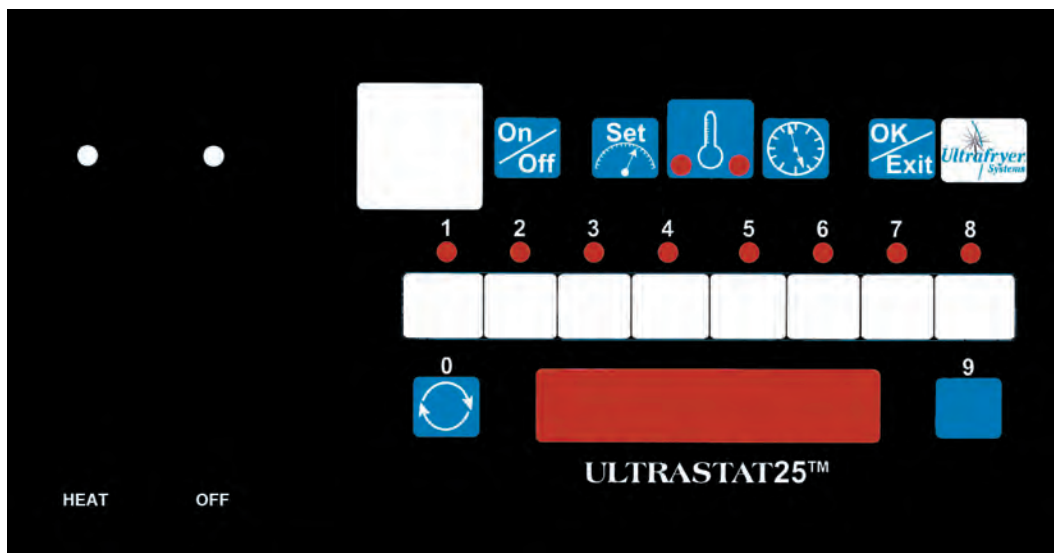

Ultrastat 21 Cooking Computer (refer to Manual P/N 30A189; French Version 30A189 FR)

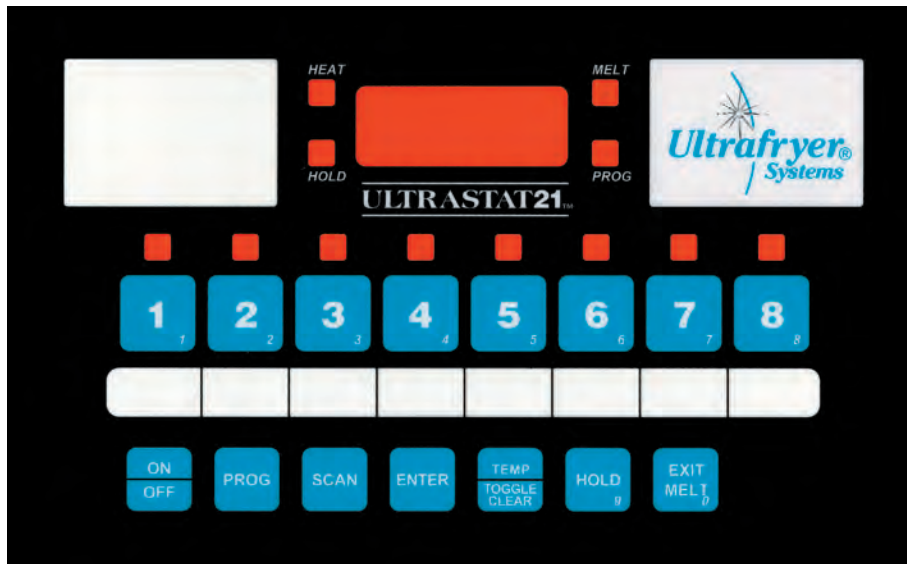

Ultrastat 11 Cooking Computer (refer to Manual P/N 30A191; French Version 30A191 FR)



**INITIAL START-UP**

**WARNING - ELECTRIC GROUNDING INSTRUCTIONS**

**This appliance is equipped with a three-prong (grounding) plug for your protection against shock hazard and should be plugged directly into a properly grounded three-prong receptacle. Do not cut or remove the grounding prong from this plug.**

- A. **CLEANING:** New units are wiped clean at the factory to remove any visible signs of dirt, oil, grease, etcetera, remaining from the manufacturing process. Each fryer vessel should be thoroughly washed with hot soapy water to remove film residues, installation dust or debris; rinsed and then wiped dry before being used for food preparation.
- B. **START-UP:** The fryers are tested, adjusted and calibrated prior to being shipped: however adjustments may be necessary on installation to meet local conditions, high or low gas pressure, differences in altitudes, variations in gas characteristics and to correct possible problems caused by rough handling or vibration during shipment. Initial calibration or adjustment is the responsibility of the customer and will not be covered by the Ultrafryer Systems warranty.

**NOTE:** Calibration and adjustments must be performed by qualified personnel.

- C. **LIGHTING INSTRUCTIONS:** Each fryer is equipped with a spark ignition system and to test this system, perform the following steps, in sequence:
  - 1. Turn the Toggle **ON/OFF SWITCH** to the **OFF** position.
  - 2. Fill the fryer vessel with hot or cold water to the **SHORTENING LEVEL** mark on the rear wall of the fryer vat.

**CAUTION : IF THE MAIN BURNERS ARE OPERATED WITH THE VESSEL EMPTY, THE HEAT WILL CAUSE THE JOINTS OF THE FRYER VESSEL TO BE PLACED UNDER UNDO STRESS AND MAY CAUSE THE HEAT EXCHANGER VESSEL TO WARP OR BUCKLE, VOIDING WARRANTY.**

- 3. Turn the manual gas valve located behind the fryer Service Access door to the **OFF** position and wait **FIVE (5)** minutes for any accumulated gas to disperse.
- 4. **ENSURE** the **MAIN** gas shut-off is in the **ON** position, **MANUAL VALVE** on the combination **GAS CONTROL VALVE** (located behind the fryer Service Access door) is in the **ON** position and the Vent Hood **EXHAUST FAN** is **ON**.
- 5. Turn the manual gas valve to the **ON** position.
- 6. Turn the **ON/OFF** switch **ON**; then place the **DTMR** or **ULTRASTAT** Cooking Computer into the **MELT MODE**.

**WARNING!!! DO NOT USE A MATCH OR CANDLE TO LIGHT A FRYER... EVER!**

- D. **SEQUENCE OF IGNITION:** When the lighting instruction steps are performed in the sequence listed above, the following will occur:
  - 1. Blower will come **ON** activating the air pressure switch.
  - 2. The air pressure switch will **CLOSE** completing the electrical circuit to the **IGNITOR MODULE** and **GAS CONTROL VALVE**, and the ignitor will **SPARK**, lighting the gas in the burner.

**WARNING!!! WHEN CHECKING FOR BURNER PERFORMANCE, DO NOT STAND WITH YOUR FACE CLOSE TO THE BURNER.... IT MAY LIGHT WITH A "POP" AND COULD FLASH BACK AND CAUSE FACIAL BURNS.**

- NOTES:**
- 1) If the burner flame fails, it will be sensed by the **SPARK IGNITOR**, the Spark Ignitor Module will open the electrical circuit to the **GAS CONTROL VALVE** shutting off gas to the burner.
  - 2) If the blower fails, the air pressure switch will open the electrical circuit to the **SPARK IGNITOR MODULE** and **GAS CONTROL VALVE**, shutting off gas to the burner.

- E. **BURNER OPERATION TEST:** Perform above **LIGHTING INSTRUCTIONS** and observe operation of the burners. When satisfied that the burner is operating properly, drain the fryer vessel of water and dry the vessel thoroughly; then fill the fryer vessel with shortening. Refer to the accompanying Computer Controller manual for more information.
- F. **TEST START-UP:** Refer to the accompanying Computer Controller manual for procedures on test operating the fryer.

**ABBREVIATED OPERATING INSTRUCTIONS**

**WARNING - To Avoid Injury:**

1. Do not move a fryer filled with hot liquid.
2. Always wear oil-proof, insulated gloves when working with a fryer filled with hot oil.
3. Always drain hot oil into a metal container. Hot oil will melt plastic buckets or shatter glass.

**A. GENERAL:** This gas fryer is equipped with a shortening filter system which is to be operated and cleaned according to the FRYER OPERATION section of this manual.

1. **SHORTENING:** Use a high quality shortening to achieve a consistent quality product as well as a long term savings.
2. **SHORTENING TEMPERATURE:** Most products should be cooked with a shortening temperature about 350°F (177°C); however, each product should be cooked at the **LOWEST** temperature that produces a high quality product while obtaining maximum usage of the shortening.
3. **SALTING:** Products should not be salted over the fryer vessel as salt quickly deteriorates the shortening and flavors other products cooked in the same shortening.
4. **POWER FAILURES:** The fryer cannot be operated during power failures. **DO NOT** attempt to manually operate the fryer.
5. **PUMP MOTOR:** The filter pump motor is protected by a motor thermal overload switch.

**CAUTION: ENSURE THE WASH WAND HOSE IS NOT CONNECTED TO A FRYER PRIOR TO RESETTING A THERMAL OVERLOAD SWITCH.**

**B. COOKING:** Refer to the included Cooking Computer Manual for specific procedures on operating the fryer using the cooking computer.

Computer	Manual Number
U03 / DTMR	30A192 (French: 30A192 FR)
U11	30A191 (French: 30A191 FR)
U21	30A189 (French: 30A189 FR)
U25	30A190 (French: 30A190 FR)

**C. FILTERING SHORTENING :**

1. **If the customer decides to use a shortening filtration system** (whether provided by Ultrafryer or from another source), then the fryer must be filtered at least twice a day (once after the lunch rush and again after the dinner rush).
2. Place the recommended amount of filter agent in the shortening as prescribed by the chemical supplier.
3. Follow the procedures outlined in the appropriate included filtration manual:

Filtration Topic	Manual Number
General Filtration Procedures	30A181 (French: 30A181 FR)
“R” Filtration Procedures	30A182 (French: 30A182 FR)
“S” Filtration Procedures	30A183 (French: 30A183 FR)
“T” Filtration Procedures	30A184 (French: 30A184 FR)
Portable Filtration Machine Procedures	30A211 (French: 30A211 FR)

**WARNING: CRUMBS AND SLUDGE LEFT IN THE FILTER TUB OVERNIGHT ARE A FIRE HAZARD.**

**D. LEVELING SHORTENING:** After filtering, the shortening level must be checked and fresh shortening added when necessary.

1. The shortening in the vat should reach to the middle line of the “E” in the word LEVEL of the shortening level mark on the rear wall of the fryer.
2. If shortening is needed, use the filter scraper to cut off a small block of solid shortening.
3. Place the small block of shortening into a fry basket, lower the basket into the shortening; then turn the basket to allow the block to float freely.
4. Repeat the above steps until the shortening in the vat is at the proper level.

**E. BOILING OUT FRYER:** The fryer should be **BOILED OUT** every **7 DAYS** to remove carbon buildup and other encrusted materials. Add the amount of boil out compound to the fryer as prescribed in the cleaning manual provided by the chemical supplier and follow instructions for boiling out a fryer in the “General Filtration Procedures” manual (UFS # 30A181).

**F. CLOSING / SHUTDOWN INSTRUCTIONS:**

1. **CLOSING:** When closing at night; filter the shortening in the fryer, **THOROUGHLY** drain all filter lines and cover the fryer vessel. Turn the **ON/OFF** Switch on the fryer **OFF** and turn the Manual Gas Valve **OFF**.
2. **SHUTDOWN OR PROLONGED POWER FAILURE:**
  - a. Shutdown: Perform the following whenever a fryer is being shutdown for an extended period of time:
    - 1) Drain and discard the shortening.
    - 2) **THOROUGHLY** clean the fryer vat.
    - 3) Turn the ON/OFF Switch to the **OFF** position, disconnect the 120-volt power cord and turn applicable Circuit Breakers **OFF**.
    - 4) Turn the Manual Gas Valve **OFF**.
  - b. Prolonged power failure: The gas fryer cannot be operated during power failures. **DO NOT** attempt to bypass safety controls and manually start the fryer.

**PREVENTIVE MAINTENANCE & TROUBLESHOOTING**

- A. **PREVENTIVE MAINTENANCE:** Minimal maintenance is required on a gas fryer because of its design and the materials used in the manufacturing process. However, some preventive maintenance and inspection must be performed periodically to prevent break downs which could curtail food sales.

Any preventive maintenance or inspection should be accomplished with **CAUTION** while the fryer is in operation since **HOT** liquid shortening could cause severe burns. If service or repair is required, all gas and electric power **MUST BE TURNED OFF PRIOR TO** performing that service or repair.

<b>PREVENTIVE MAINTENANCE SCHEDULE</b>		
<u>INSPECTION ITEM</u>	<u>INSPECTION PRIORITY</u>	<u>INSPECTION DESCRIPTION</u>
Grease Filters	DAILY	Clean grease filters in the exhaust vent hood each evening and allow them to dry overnight.
Filter Tub (if applicable)	DAILY	Thoroughly clean the filter tub assembly prior to leaving the store at closing
Drain Valve & Shortening Return Levers	WEEKLY	Determine that all levers are securely attached and that they can be easily opened and closed.
Temperature Sensing Probes	WEEKLY	During Boil-Out of the fryer, inspect the temperature and high limit sensing probes for any visual damage.
Blower Motor	SEMIANNUALLY	A qualified technician or authorized service agent should inspect and thoroughly clean the motor of dirt and debris every SIX (6) MONTHS.
Agitator Baffle	SEMIANNUALLY	A qualified technician or authorized service agent is to remove and inspect the agitator baffle in each fryer for metal fatigue or weld deterioration every SIX (6) MONTHS. If no defect is found, reinstall the original baffle.
<b>NOTE:</b> Slight warp or a few broken fins is normal wear. DO NOT REPLACE during semiannual inspection.		
Agitator Baffle	ANNUALLY	A qualified technician or authorized service agent is to install a NEW agitator weldment in each fryer AUTOMATICALLY every TWELVE (12) MONTHS.

**B TROUBLESHOOTING**

The problems and possible solutions listed in the troubleshooting chart below are typical problems that are frequently encountered. **ONLY** qualified repairmen are to use the troubleshooting chart to repair this fryer. In the event a main burner malfunction occurs, perform the following checks **PRIOR** to contacting a repairman:

- a. Ensure Gas Valves are in their proper position.
- b. Check that the fryer electrical plug is connected to an electrical receptacle.
- c. Ensure the applicable Circuit Breaker is in the **ON** position and that the fryer ON/OFF switch is in the **ON** position.
- d. Ensure the applicable fryer control has been placed in the **FULL ON** mode.
- e. Ensure the gas supply line quick-disconnect coupling is **SEATED** on the gas manifold fitting.
- f. Determine that the blower is operating.

- C **TROUBLESHOOTING CHART:** Should a problem occur that cannot be corrected after performing the above CHECKS, contact an **AUTHORIZED** repairman and/or Ultrafryer Systems Customer Service 1-800-525-8130 and provide the information acquired while performing these checks.

**CAUTION: ENSURE REPAIRMEN ARE ADVISED THAT FRYER RESTRAINTS MUST BE DISCONNECTED/CONNECTED. IF A FRYER IS TO BE MOVED DURING MAINTENANCE OR REPAIR, AND THAT ELECTRICAL POWER AND GAS MUST BE TURNED OFF PRIOR TO PERFORMING ANY MAINTENANCE OR REPAIR.**

TROUBLESHOOTING CHART		
ITEM	PROBLEMS	POSSIBLE SOLUTIONS
1	Main burner will not ignite. Blower is operating; but gas is not present at the burner.	<p>A. Check the Blower air pressure Switch by temporarily disconnecting the two (2) air switch wires and connecting them together. If the <b>IGNITOR</b> sparks when these wires are connected, the air pressure switch is defective and it will have to be replaced.</p> <p>B. Check the following components and replace if found to be defective: Gas Control Valve Hi-Limit Switch Transformer</p>
2	Electrical power is present at the fryer, but the Blower is not operating.	A. Blower may have over-heated and shut off on thermal overload. If this situation did occur, it will correct itself when the motor cools (10-20 minutes). If this overheating problem persists, replace the blower motor.
3	Excessive time is required to raise the shortening to cooking temperature. Temperature recovery is slow and main burner flames are small and appear to be lethargic.	<p>A. Ensure that the <b>MANUAL GAS VALVE</b> is completely open.</p> <p>B. Check for an obstruction in the gas line.</p> <p>C. Check for an obstruction in the flue pipe.</p> <p>D. Check that the <b>ORFICE PLUG</b> has the correct drill size opening as indicated on the operational requirements chart.</p> <p>E. Check for damaged <b>BLOWER</b> fins.</p> <p>F. Use a standard water-type U-gauge Manometer to check the pressure at the gas control valve pressure tap. Proper gas pressure is indicated on the operational requirements chart.</p> <p><b>NOTE:</b> If necessary remove the Pressure Regulator Adjustment Cover and adjust this control to the proper pressure. (Turn adjusting screw <b>CLOCK-WISE</b> to increase gas pressure to the burner and <b>COUNTER CLOCKWISE</b> to decrease gas pressure. Replace adjustment cover.)</p>
4	Shortening temperature is too high and breaks down quickly.	<p>A. Check the gas pressure as described above.</p> <p>B. Check calibration of the Electronic Thermostat with an <b>ACCURATE</b> digital thermometer.</p>
5	The filter pump motor fails to operate when the Vat Shortening Return / Topside Shortening Lever is placed in the <b>OPEN</b> position.	<p>A. Insure the filter pump micro-switch is good, then check the manual reset button on the filter pump motor.</p> <p>B. If the filter pump motor fails to operate after the reset button has been depressed, repair or replace the motor.</p>
6	Decreased shortening flow rate while filtering.	A. Check for excessive sediment on the filter screen, standpipe suction fitting or in filter tub.
7	Pump/Motor operates but does not pump shortening.	<p>A. Check for congealed shortening in the shortening system.</p> <p>B. Check for loose Standpipe / Suction Line Coupler connection.</p>
8	Pump / Motor hums but will not pump shortening	A. Check for congealed shortening in the pump or in shortening plumbing.

## CLEANING

**CLEANING** - Any item of equipment operates better and lasts longer when it is kept clean and properly maintained. The Gas Fryer is no exception. In order for this fryer to provide years of trouble-free service, it must be **CLEANED** and **MAINTAINED** according to instructions herein and at the intervals listed below:

**WARNING!!! TO ASSURE PRODUCING A QUALITY PRODUCT WHILE PROLONGING THE LIFE EXPECTANCY OF THE FRYER, ENSURE FILTERING, BOIL-OUT AND CLEANING INSTRUCTIONS ARE STRICTLY FOLLOWED.**

1. Clean the fryer surface periodically during operating hours with a solution of sanitizer and hot water, and at closing with stainless steel cleaner. If necessary, use a dampened 3M type 7447 RED or 7440 BROWN (heavy duty) Scotch Brite pad to remove encrusted material. **DO NOT** use steel wool, abrasive cloths, cleaners, powders or metal devices to scrape stainless steel! Scratches on stainless steel are almost impossible to remove!

**CAUTION: DO NOT ALLOW ANY CLEANING SOLUTION OR WATER TO SPLASH INTO A VESSEL OF HOT COOKING OIL, AS IT WILL CONTAMINATE THE OIL AND MAY CAUSE THE OIL TO SPLATTER CAUSING SEVERE BURNS.**

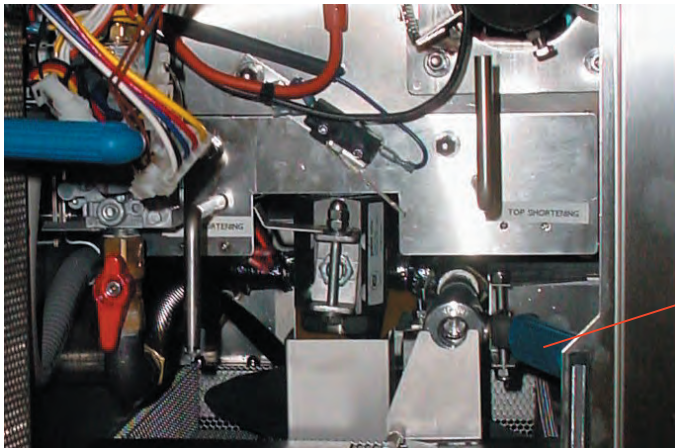

Docking Release Handle



1	Crumb Catcher Screen
2	Filter Tub Cover
3	Standpipe Docking Handle Assembly
4	Filter Tub Latch

2. If a Filter Tub Assembly is used with this fryer, then the Filter Tub Assembly and Filter Screen should be cleaned **EACH DAY AFTER FILTERING** and **AT CLOSING**, and **THOROUGHLY** cleaned once each week. To remove the Filter Tub Assembly from the fryer:
  - a. **OPEN** the Fryer's Temperature Control Access Door.
  - b. **PRESS** the **DOCKING RELEASE HANDLE**, shown above.
  - c. **PULL** the Filter Tub Assembly from the fryer using the Standpipe Docking Handle Assy.
  - d. Clean the Filter Tub Assembly according to the filtration manuals provided with the fryer:

Filtration Topic	Manual Number
General Filtration Procedures	30A181 (French: 30A181 FR)
"R" Filtration Procedures	30A182 (French: 30A182 FR)
"S" Filtration Procedures	30A183 (French: 30A183 FR)
"T" Filtration Procedures	30A184 (French: 30A184 FR)
Portable Filtration Machine Procedures	30A211 (French: 30A211 FR)

**WARNING: CRUMBS AND SLUDGE LEFT IN THE FILTER TUB OVERNIGHT ARE A FIRE HAZARD!**

## **FILTER TUB ASSEMBLY & INSTALLATION**

**NOTE: The following applies only to those fryers that are equipped with a hard dock filtration assembly from Ultrafryer Systems.**

**A. FILTER TUB ASSEMBLY - ENSURE** all components of the filter tub have been thoroughly cleaned and that the Filter Screen has been assembled; then assemble the filter tub as follows:

1. Connect the **KNURLED KNOB** to the **STANDPIPE DOCKING HANDLE ASSEMBLY**; then attach this assembly to the **SUCTION FITTING** on the Filter Screen.

**DO NOT OVERTIGHTEN THIS CONNECTION!!!**

2. Place the Filter Screen in the bottom of the Filter Tub with the screen butted against the rear wall of the tub.
3. Insert the Crumb Catcher Screen in the Filter Tub with the Drain Valve **DOCKING FLANGE** and **MALE DOCKING PLUG** over the leading edge of the pan.
4. Position the **FILTER TUB COVER** on the open end of the Filter Tub with the **SLOT** on the cover seated around the Standpipe Docking Handle Assembly. Then, **SECURE** the cover to the standpipe assembly by locking the latch on the cover.

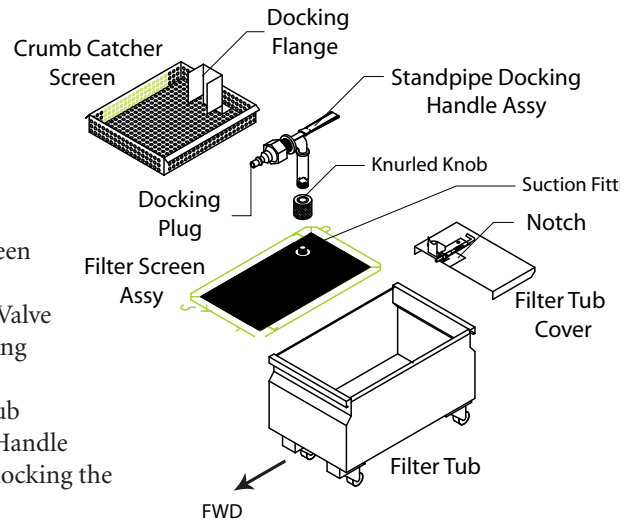

**B. FILTER TUB INSTALLATION -** Position the **ASSEMBLED** Filter Tub in front of the **FILTER TUB GUIDES** beneath the fryer; then **CAREFULLY** insert the Filter Tub into the fryer using the standpipe handle assy until the **MALE In-Line Plug** on the Docking Handle Assembly seats in the **FEMALE** Bulkhead Socket adjacent to the Drain Valve Assembly.

**TECHNICAL ASSISTANCE, ORDERING INFORMATION**

A. **TECHNICAL ASSISTANCE** - Contact an authorized service agent or the Customer Service Department, Ultrafryer Systems at 1-800-525-8130 for technical assistance.

**B. ORDERING INFORMATION:**

1. **REPLACEMENT PARTS** - Provide the following information when ordering replacement parts by phone, fax or mail:

Your company name and phone number  
Your company purchase order number  
Bill-to address  
Ship-to address  
Quantity desired  
Part number and description of the desired-item  
Your name or signature of authorized-buyer

Phone in order to: 1-800-545-9189 Ext 5029

FAX order to: 1-210-731-5099

Mail order to: Ultrafryer Systems  
Order Entry Office  
P.O. Box 5369  
San Antonio, TX 78201

E-Mail your order to: Ultrafryerservice@ultrafryer.com

2. **TERMS** - Net 30 days for customers on approved accounts. Past due balances will be charged 1% per month (12% per annum) until full balance is paid.
3. **DAMAGES** - Ultrafryer Systems is not responsible for damage occurring in transit. All deliveries must be inspected for damage to shipping containers prior to departure of the delivering carrier. Any damage must be documented on the receiving document to facilitate filing of freight claims. Carriers must be notified immediately and freight inspections must be requested from the carrier. Ultrafryer Systems can and will gladly assist you in preparing and processing of the necessary claims only if proper notification has been accomplished on the carrier delivery document. Damaged equipment and or containers must be available for the claims inspector to inspect.
4. **RETURNS** - Ultrafryer Systems cannot guarantee credit for items returned without proper authorization. All returns must have prior Ultrafryer Systems Customer Service or Warranty department approval. An assigned number will be issued by the approval authority. Please print the assigned number on all returned packages and corresponding paperwork. Returned goods are subject to a 15% restocking charge. Ultrafryer Systems is not responsible for freight charges on returned goods unless authorized by Customer Service and or Warranty personnel. Ultrafryer Systems does not receive freight collect or C.O.D. shipments.

**RECOMMENDED SPARE PARTS**

**RECOMMENDED SPARE PARTS:** To minimize downtime on the Model PAR25 gas fryer upon failure of a component part, at least one (1) of the following items should be kept as a spare part in the local area:

<b>MODEL PAR25 GAS FRYER RECOMMENDED SPARE PARTS LISTING</b>		
<u>Description</u>	<u>Manufacturer's Part Number</u>	<u>PN</u>
Ignitor Spark Module	Honeywell S87B1008	18179
24 Volt Stepdown Transformer	Honeywell AT40A1121	18180
24 Volt Combination Gas Control Valve	Honeywell VR8203A-1005	18227
DPST Toggle ON / OFF Switch	---	18A081
Air Pressure Switch	SMD 1204	18A291
Hi-Limit Switch Model 103KM1	Stemco 103K	19A144
½" (13mm) Apollo Pump Control Valve	Brass Craft TBV8	24036
¼" (5mm) Compression Fitting	---	24247
½" (13mm) Manual Gas Valve	Glacomini R602	24326

**PARTS IDENTIFICATION**

- C. **PARTS IDENTIFICATION:** Locate the part on the following sketches and note the index number i.e, 3, 6, etc; then obtain the part number and description for that index number on the page facing the sketches. Use that part number when ordering a replacement part.

**ULTRAFRYER MODEL PAR25 GAS FRYER  
FRONT VIEW**

*Note: Fryer shown is 18" Par25 without Filtration. For information on other fryer models, contact Ultrafryer Customer Service.*

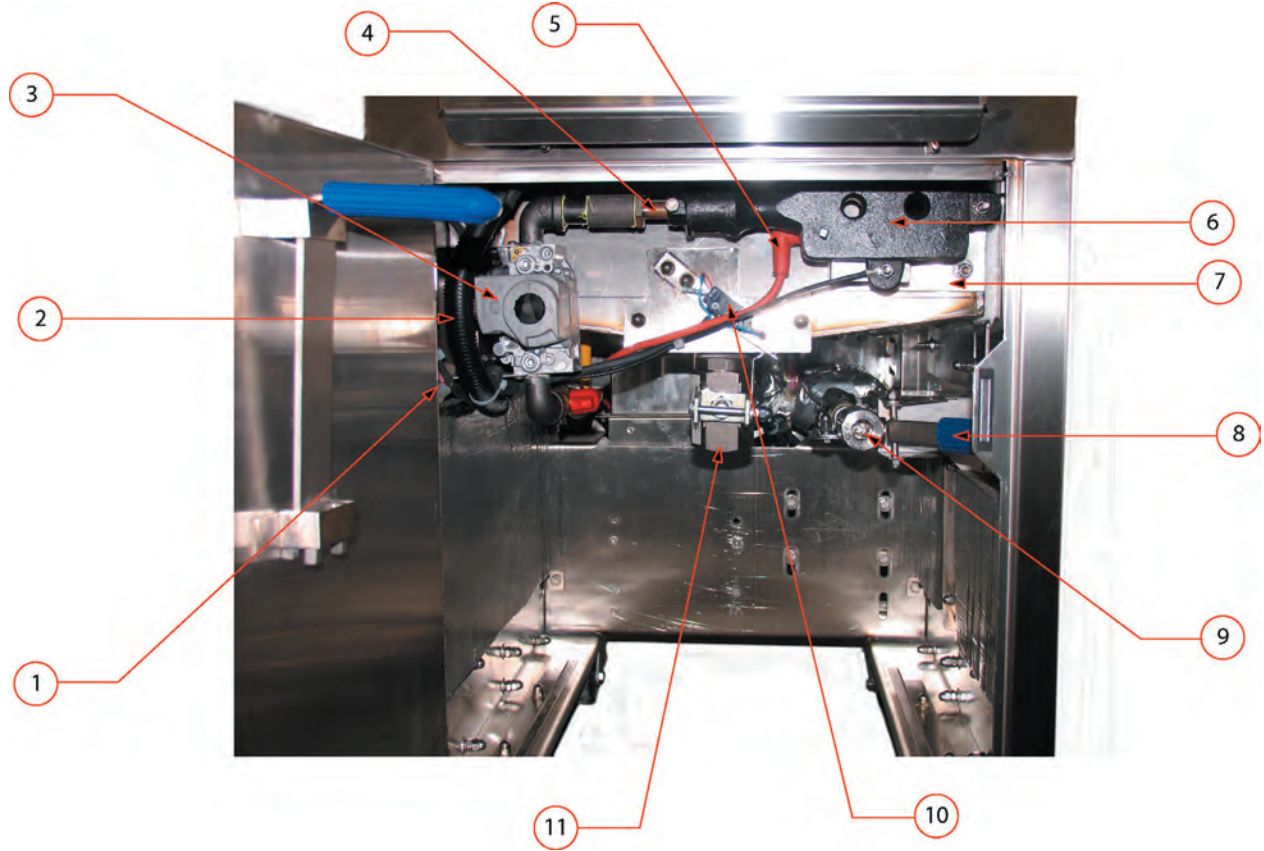

<u>ITEM</u>	<u>DESCRIPTION</u>	<u>PN</u>
1	Hi-Limit Switch	19B782 (14" fryer) 19B783 (18", 20", or 24" fryer)
2	Main Cable	12B711
3	Gas Regulator / Shutoff Valve	18227 / 24326
4	Orifice	<i>see chart, page 7</i>
5	Ignitor Wire	18A095
6	Burner	22A341
7	Burner Bracket	19B505
8	Docking Release Handle (for fryers with filter tub)	19C177
9	Docking Connection	24A238
10	Micro Switch ( <i>optional</i> )	18185
11	Main Drain Valve	19A564 (14" or 18" fryer) 12B886 (18" or 20" fryer)

**ULTRAFRYER MODEL PAR25 GAS FRYER  
REAR VIEW**

*Note: Fryer shown is 14" Par25 with Filtration. For information on other fryer models, contact Ultrafryer Customer Service.*

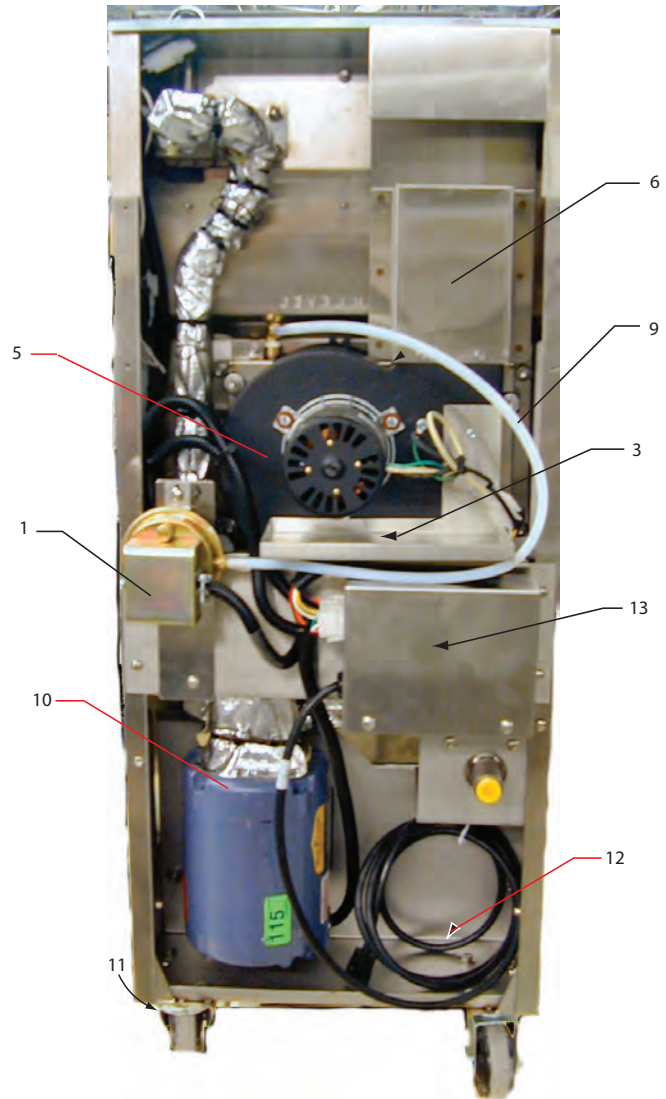

*Note: Parts listed below are for 14" Par25 with Filtration. For information on other fryer models, contact Ultrafryer Customer Service.*

ITEM	DESCRIPTION	PN
1	Model SMD 1204 Air Pressure Switch	18A291
* 2	Rear Exit Weldment Baffle	19A463
3	Exhaust Blower Motor Drip Pan	19A527
* 4	14" Model PAR25 Exhaust Blower Motor Gasket	19A545
5	14" Model PAR25 115 Volt 60 HZ Exhaust Blower Motor Kit w/Mounting Bracket	19A547
6	14" Model PAR25 5¾" x 8" High (146 x 208mm) Rectangular Flue Tube with deflector	19A910
* 7	125 Volt 75 Watt Silicon Heater 5' (1524mm) Long	23341
* 8	Gemini ½" (13mm) Pump Ball Valve	24-036
9	3/16" (5mm) ID, 5/16" (8mm) OD Air Pressure Switch Plastic Tube rated for 500° F (260°C)	24A068
10	Model GPV-0514 5.5 GPM (19.25 LPM) Viking Pump/Motor Kit. <b>NOTE:</b> For replacement, Pump Only order 24339.	24A206
11	Medium Duty 3" (76mm) Rear Caster w/out Brake	28A011
12	Type SJO 16/3 Electrical Cord with 90° Molded Plug	33048

\* NOT SHOWN

**ELECTRONIC THERMOSTAT  
PN 12B077**

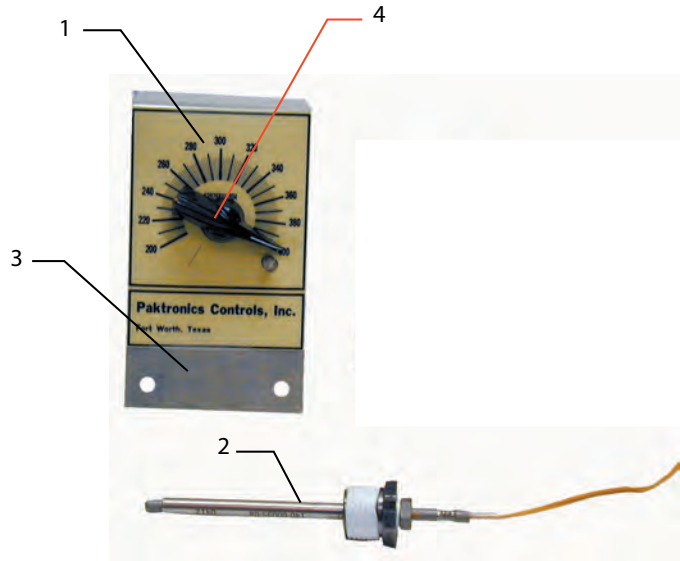

<u>ITEM</u>	<u>DESCRIPTION</u>	<u>PN</u>
1	Electronic Thermostat Face Plate	18A070
2	Temperature Probe	18A276
3	Electronic P14 Thermostat Bracket	19B174
4	Electronic Thermostat Knob	22A169

**PAR25 EZ DOCK FILTER TUB ASSEMBLY**  
**14" With Micromesh Filter PN 12B112**  
**14" With Magnepad Filter PN 12B177**

ITEM	DESCRIPTION	PN
*1	Filter Tub Scraper	12567
2	Micromesh S/S Filter Screen Assembly with StandPipe & Docking Assembly	12B113
*3	Magnepad Magnesol Impregnated Filter Pad with Standpipe and Docking Assembly	12B178
*4	Wash Down Hose Assembly	12B115
5	Filter Tub cover with hinge latch and Proximity sensor actuator for 14" Filter Tub	19B227
*6	Proximity Actuator Sensor	18A059
7	14" Model PAR25 Filter Tub	19B227
8	14" Model PAR25 Crumb Catcher Screen	19B233
9	RH S/S Hinge Latch	22479
10	Medium Duty Caster	28A005

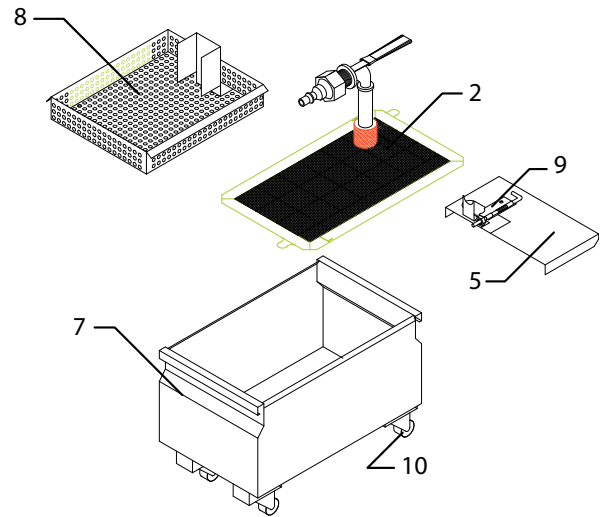

\* NOT SHOWN

**WASH WAND HOSE ASSEMBLY**  
**PN 12B115**

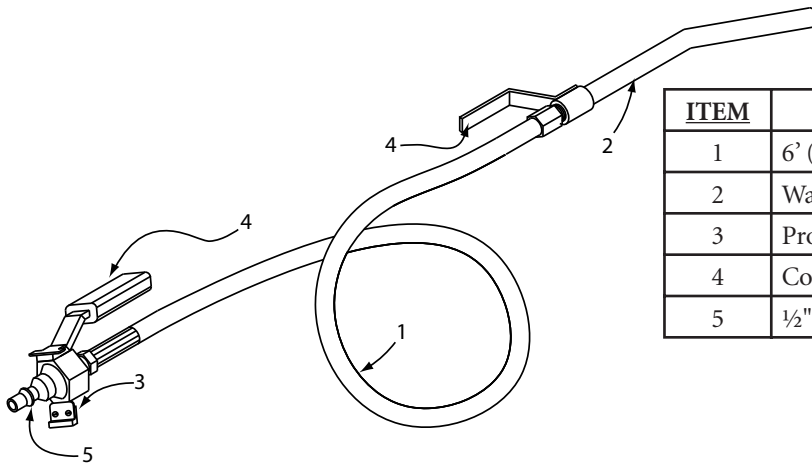

ITEM	DESCRIPTION	PN
1	6' (1829mm) Wash Wand Hose w/Fittings	12541
2	Wash Wand Hose & Nozzle Assembly	12675
3	Proximity Sensor Actuator	18A059
4	Cool II Handle	22734
5	1/2" (13mm) S/S Locking Seal Inline Plug	24A208

ITEM	DESCRIPTION	PN
1	Micro-Mesh S/S Filter Screen	21A278
2	Handle Assy, Weld 1/2" (13mm) Street Elbow	19A598
3	Top Compression Cap (Knurl Knob)	24369
4	1/2" (13mm) x 7" (178mm) Black Iron Nipple	24471
5	1/2" (13mm) S/S Locking Seal Inline Plug	24A208

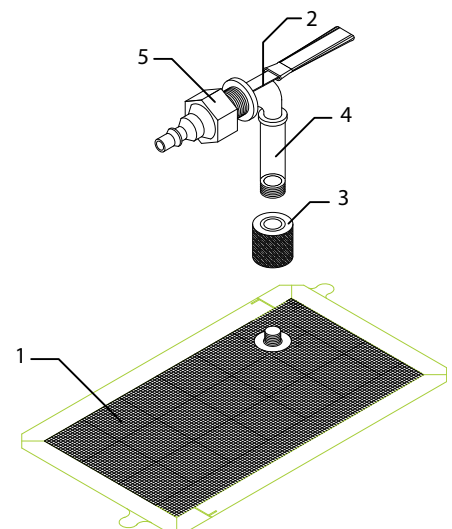

**MICRO-MESH FILTER ASSEMBLY**  
**WITH STANDPIPE & DOCKING ASSEMBLY**  
**PN 12B113**

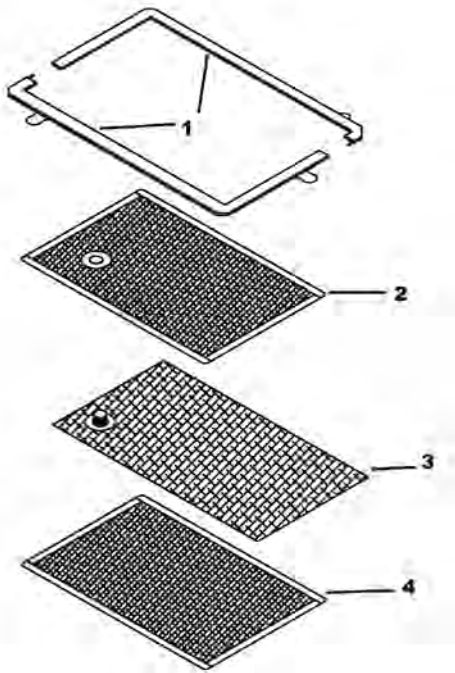

FILTER SCREEN ASSEMBLY		
ITEM	DESCRIPTION	PN
1	Replacement Frame Set	21A284
2	Replacement "Upper" Screen	21A285
3	Replacement Baffle Assembly	21A286
4	Replacement "Lower" Screen	21A287

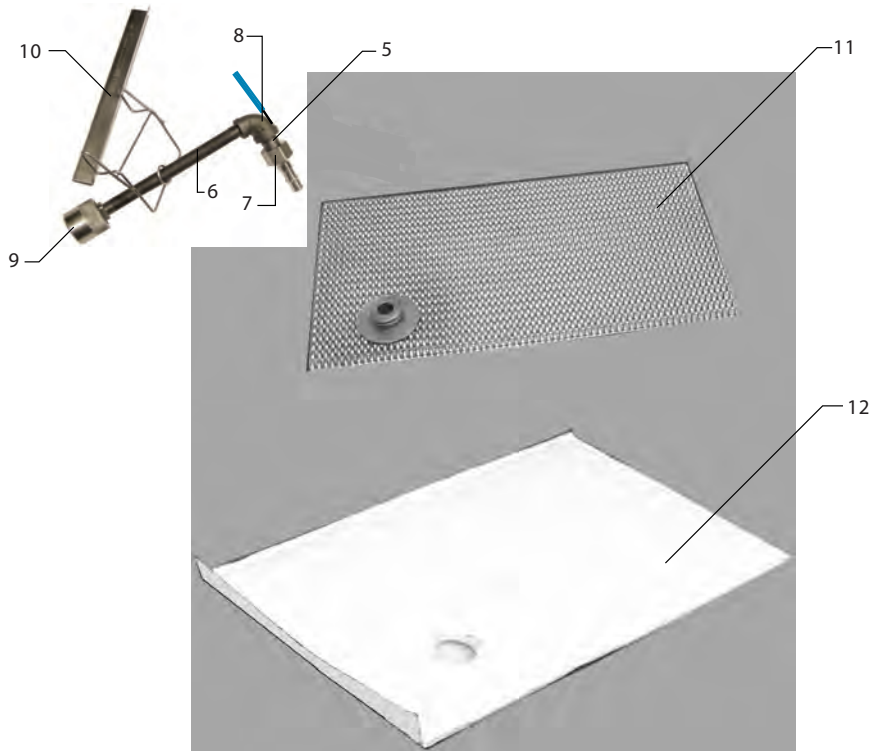

STANDPIPE CLIP, BAFFLE AND MAGNEPAD ASSEMBLY PN 12B178		
ITEM	DESCRIPTION	PN
5	1/2" (13mm) Black Iron Close Nipple	24003
6	3/8"(10mm) x 7" (177.8mm) Black Iron Nipple	24470
7	1/2" (13mm) S/S Locking Seal Inline Plug	24A208
8	1/2" (13mm) Handle Assy With 90° Black Iron Elbow	19A598
<b>11" x 18 1/4" (279mm x 464mm) Baffle Kit consists of items 9,10&amp;11</b>		29A058
9	Top Compression Cap (Knurl Knob)	24A153
10	11" (279mm) Standpipe Clip	29A052
11	9 3/8" x 16 7/8" (238mm x 429mm) Baffle	29A060
12	11" x 18 1/4" (279mm x 464mm) Filter Pad	29A059
Case of (PN 29A059) Filter Pads		29A057

\* NOT SHOWN

**ULTRAFRYER MODEL PAR25 GAS FRYER  
AUTOMATIC VAT CLEANER  
14" PN 12B157**

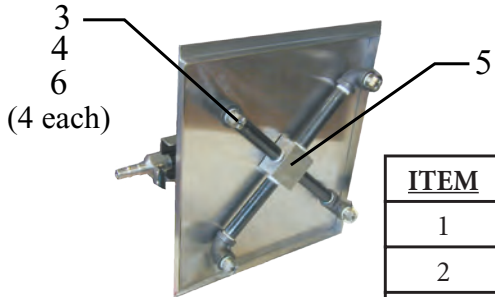
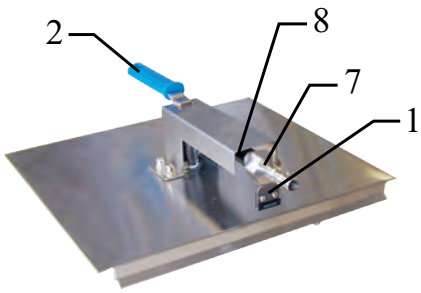

<u>ITEM</u>	<u>DESCRIPTION</u>	<u>PN</u>
1	Proximity Actuator Sensor	18A059
2	Cool II Handle	22734
3	½" (13mm) HH-2236 SQ Spray Nozzle	22A111
4	½" (13mm) x 90° Black Iron Elbow	24007
5	½" (13mm) 5 Way Black Iron Crossover Manifold	24A082
6	14" PAR25 ½"(13mm) x 5¼" (133mm) Black Iron Nipple	24A101
7	½" (13mm) S/S Locking Seal Inline Plug	24A208
8	½" (13mm) x 6" (152mm) Black Iron Nipple	24A178

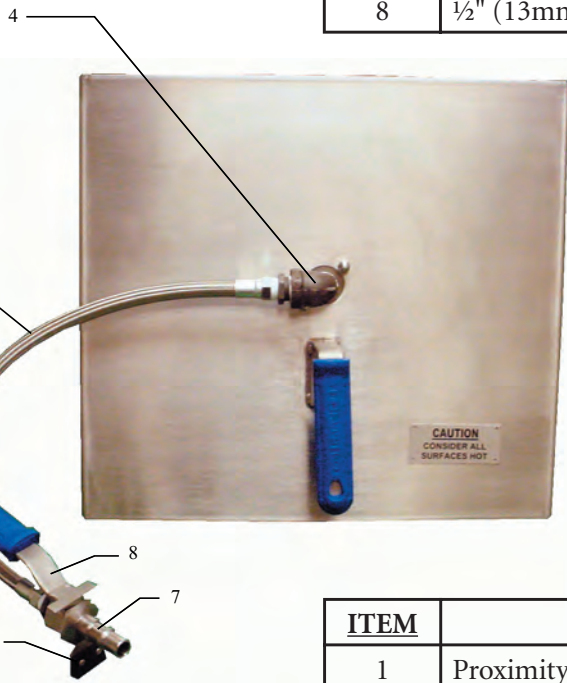

**ULTRAFRYER MODEL PAR25 GAS FRYER  
AUTOMATIC VAT CLEANER  
14" PN 12B434**

<u>ITEM</u>	<u>DESCRIPTION</u>	<u>PN</u>
1	Proximity Actuator Sensor	18A059
2	Cool II Handle	22734
4	½" (13mm) x 90° Black Iron Street Elbow	24256
7	Handle Assy, P3H Weld Coupling Male	19B242
8	½" (13mm) S/S Locking Seal In-Line Plug	24A208
9	½" (13mm) x 21" (533mm) AVC Flexible Shortening Line	24A220

## WIRING DIAGRAMS

**WIRING DIAGRAM** - Since minor wiring changes may occur in the future, **USE** the diagram pasted to the fryer for circuit tracing and/or troubleshooting a gas fryer.

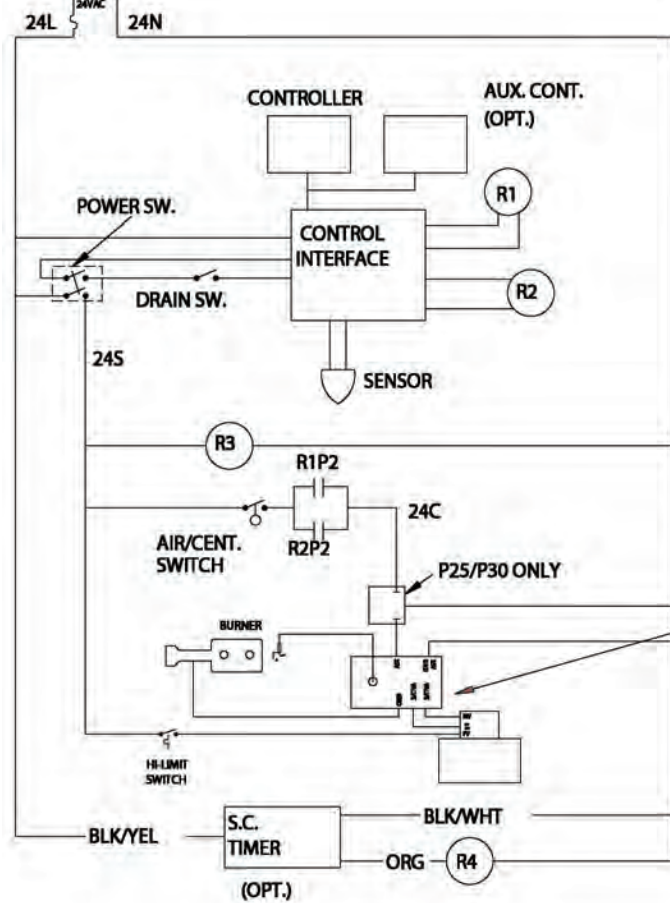
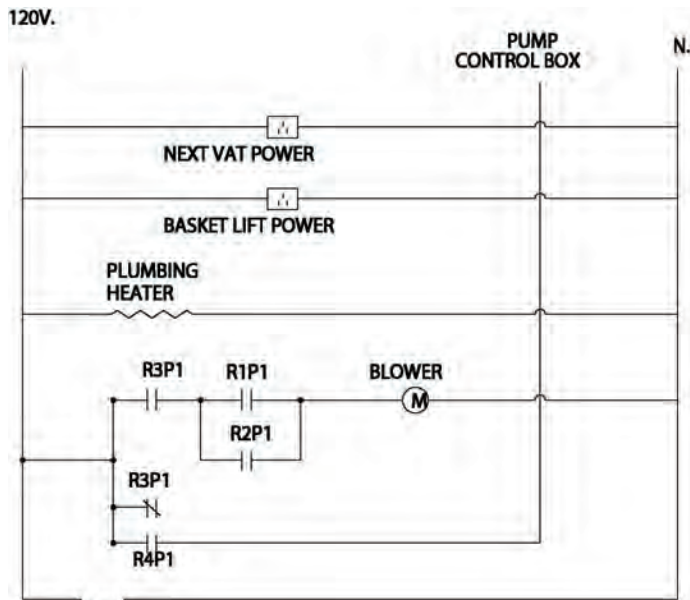

**THIS DECAL IS LOCATED ON THE FAR RIGHT SIDE BACK PANEL FROM FRONT**

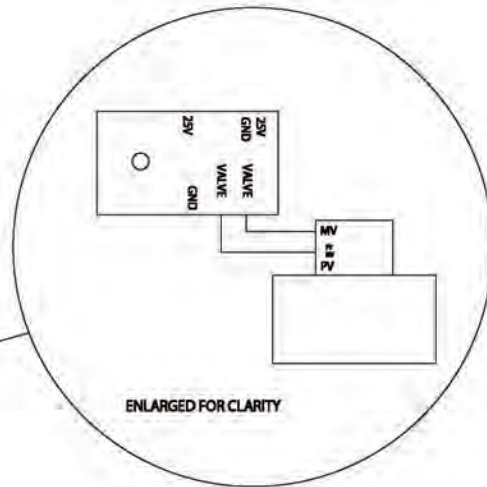

**30A171**