



ULTRAFRYER[®] SYSTEMS



ULTRAFRYER PAR-2-20F CE GAS FRYER OPERATING INSTRUCTIONS

WARNING: THIS APPLIANCE IS FOR PROFESSIONAL USE AND IS TO BE USED ONLY BY QUALIFIED PERSONNEL.



302 Spencer Lane • P.O. Box 5369

(800) 525-8130 • (210) 731-5000 • FAX: (210) 731-5099

<http://www.ultrafryer.com>

San Antonio, Texas 78201

PREFACE

This manual was written and published by the Technical Publications Department, Ultrafryer Systems, for use by store employees who will operate and maintain an Ultrafryer Systems Model Par-2-20F CE Gas Fryer. Proper use of this Manual will allow store employees to properly operate, clean and maintain this equipment which will reduce service call expenses.

TECHNICAL PUBLICATIONS DEPARTMENT
ULTRAFRYER SYSTEMS
302 SPENCER LANE
San Antonio, TX 78201
Telephone: 1-800-545-9189 Ext. 5007

NOTE: THIS MANUAL IS APPLICABLE TO ULTRAFRYER MODEL PAR-2-20F CE GAS FRYERS

TABLE OF CONTENTS

	PAGE
GENERAL INFORMATION	
SAFETY	2
MODEL PAR-2-20F CE GAS FRYER OPERATIONAL REQUIREMENTS	3
DESCRIPTION / SPECIFICATIONS	3
COOKING CONTROL	4
EUROPEAN PRESSURES, GASES & SPECIAL CATEGORIES TABLE	4
INSTALLATION, START-UP, AND INITIAL CLEANING	
GENERAL	6
RATING PLATE	6
PREINSTALLATION	6
CLEARANCES	6
STANDARDS	6
AIR SUPPLY & VENTILATION	6
RECEIVING & INSTALLING THE FRYER	7
INSTALLING	7
LEVELING	9
INLET GAS REQUIREMENTS	10
ELECTRICAL CONNECTION	11
START-UP	11
INITIAL CLEANING	13
SHORTENING INSTALLATION	13
PREVENTIVE MAINTENANCE, TROUBLESHOOTING AND CLEANING	
PREVENTIVE MAINTENANCE	15
TROUBLE SHOOTING	15
CLEANING	17
FRYER OPERATION	
GENERAL	21
ULTRASTAT 21 COOKING COMPUTER	21
START-UP AND COOKING	24
FILTER TUB ASSEMBLY	25
FILTERING SHORTENING	28
FRYER BOIL-OUT	31
SERVICE AND PARTS	
TECHNICAL ASSISTANCE	41
ORDERING INFORMATION	41
PARTS IDENTIFICATION	41
WIRING DIAGRAM	
	49

GENERAL INFORMATION

SAFETY

The major safety factor associated with the Ultrafryer PAR-2-20F CE Gas Fryer is burns from hot shortening. In order to prevent serious burns, good housekeeping habits are required. The floor in front of and the area around the fryer should be kept clean and dry. Whenever anything is placed in to a fryer vat, care should be used not to splash the hot shortening. Product should always be “**PLACED**” into the shortening, not thrown. Safety goggles, neoprene insulated gloves and an apron must be worn while filtering or boiling-out a fryer vat. Electrical controls used in the PAR-2-20F CE Gas Fryer operate on 230 volts single phase electrical power and no adjustments or replacement of electrical controls should ever be attempted without first disconnecting electrical power. The fryer should never be operated with wet hands or while standing in water. To do so can result in serious electrical shock or death.

WARNING: THIS APPLIANCE IS FOR PROFESSIONAL USE AND IS TO BE USED ONLY BY QUALIFIED PERSONNEL.

The basic Ultrafryer PAR-2-20F CE Gas Fryer is equipped with the following safety features:

- 1) High limit thermostat to shut off gas to the main burners by opening a solenoid-actuated safety valve in the combination gas control valve.
- 2) Combination gas control valve which includes a built-in pressure regulator and manual valve.
- 3) Air pressure switch to open the 24 volt electrical circuit to the combination gas control valve, turning gas to the fryer **OFF**.
- 4) Sensing circuit within the spark ignitor module to turn gas to the fryer **OFF** if a burner **FLAME OUT** occurs.
- 5) A Drain Valve Safety Switch, and a Default-to-Off circuit in the Ultrastat 21 Cooking Control that will **DISABLE** the fryer each time the drain valve is **OPENED**.
- 6) A Surge Protector that will **FILTER** “Power Spikes” should they occur.



The Ultrafryer Model PAR-2-20F CE Gas Fryers were designed by Ultrafryer Systems in a 20” (508 mm) version to operate as an energy-efficient gas fired fryer. It is manufactured to operate on either NATURAL, BUTANE or PROPANE gas according to the following Operational Requirements. The Model PAR-2-20F CE gas fryer is equipped with a “basic” Central Filtration System. Each Fryer is shipped completely assembled with accessories packed inside the fryer vat and each fryer is adjusted, tested and inspected prior to shipment. The PAR-2-20F CE Gas Fryer is designed to be used in a commercial food preparation environment after it is properly installed as outlined in this manual.

MODEL PAR-2-20F CE GAS FRYER OPERATIONAL REQUIREMENTS

MODEL PAR-2-20F CE OPERATIONAL REQUIREMENTS	
<u>ITEM</u>	<u>PAR-2-20F CE</u>
Shortening Capacity High Level Low Level	138 lbs (69 liters)
Gas Valve Setting	Note
Orifice Drill Size	Note
Inlet Gas Pressure	Note
Energy Input	230 V 6 AMPS 50 HZ 1 PHASE

NOTE: See European Pressures, Gases and Categories Table on page ?

**WHERE ARE EUROPEAN PRESSURES,
GASES & CATEGORIES???????**

DESCRIPTION / SPECIFICATIONS

The Ultrafryer Model PAR-2-20F CE Gas Fryer is constructed from 16 and 18 gauge type 304 polished stainless steel. Both models of gas fryers are equipped with an Ultrastat 21 Cooking Computer. The Model PAR-2-20F CE gas fryer is equipped with a “basic” Filtration System . The specifications, dimensions and gas ratings of a MODEL PAR-2-20F CE Gas Fryer are as follows:

<u>ITEM</u>	<u>PAR-2-20F CE</u>
Overall Width	21¾” (552 mm)
Overall Depth	38¾” (984mm)
Work Height	36 “ (914 mm)
Vat Opening Size	20” x 20” (508 x 508 mm)
Oil Capacity	
High Level	138 lbs (69 Liters)
Low Level	----
Gas Rating	Note
Electrical Requirements	230 Volt 1 Phase 50 Hz
Shipping Cube	17.04 ft³ (.48 m³)
Shipping Weight	325 lbs (146 kgs)

NOTE: See European Pressures, Gases and Categories Table on page ?

**WHERE ARE EUROPEAN PRESSURES,
GASES & CATEGORIES???????**

COOKING CONTROL

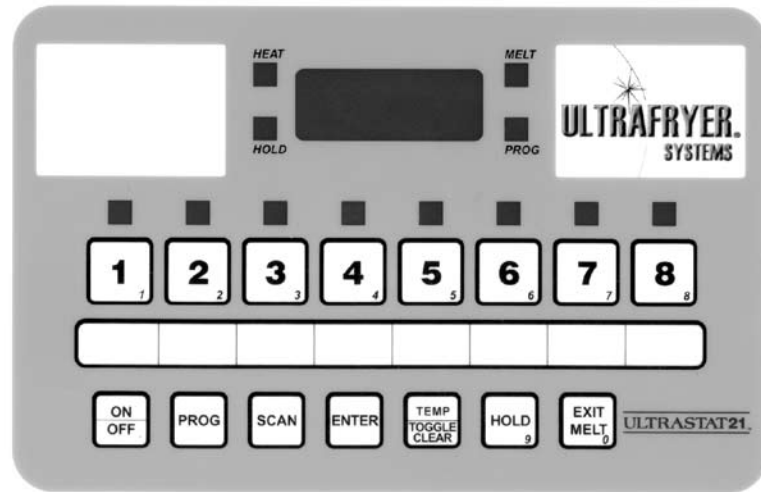

ULTRASTAT 21 COOKING COMPUTER

The Ultrastat21 Cooking computer is in compliance with the limits for a class B computing device pursuant to Sub-Part J of Part 15 of the FCC Rules. This cooking computer is capable of cooking up to eight (8) different products; each of which can be programmed to be cooked from one (1) to ten (10) different temperature at different times in a cook cycle. In addition, the operator can program the ULTRASTAT21 computer to cook products under “flex” or “STRAIGHT” timing modes. When programmed for “FLEX” time mode the computer will adjust the actual cook time taking into consideration the temperature variation due to load size, initial product temperature, product moisture content, and other factors that affect the cook cycle. Under “STRAIGHT” time mode, the product is cooked at a specified temperature for the length of time programmed without adjusting for these variations. Operation of the ULTRASTAT21 cooking computer is covered in the ULTRASTA21 Gas Fryer Computer Operation Instructions PN 30A009 provided with the Gas Fryer.

SPACE RESERVED FOR EUROPEAN PRESSURES, GASES & SPCL CATEGORIES TABLE

AWAITING FROM FRED SAPORSKY

**WHERE ARE EUROPEAN PRESSURES,
GASES & CATEGORIES???????**

INSTALLATION, START-UP AND INITIAL CLEANING

INSTALLATION

GENERAL : Each Model PAR-2-20F CE fryer should be installed as follows:

- A. Placed beneath a properly designed exhaust hood.
- B. Installed by a licensed plumber.
- C. Connected to the type gas for which the unit was fabricated as shown on the rating plate.
- D. Connected to the proper size pressure regulator installed in the gas supply line and adjusted to the proper manifold pressure.
- E. Connected to the main gas supply line with the proper size supply line.
- F. Restrained by use of a restraining device to avoid splashing of hot liquid and to assure tension cannot be placed on the flexible gas line or fittings.

RATING PLATE: Information on this plate includes the model and serial number; BTU/HR (MJ/HR) input rating of the burners; gas manifold pressure in inches W.C. ; minimum inlet gas pressure, orifice size; and type of gas acquired from the European Pressures, Gases and Special Categories Table on page 4.

THE FRYER MUST BE CONNECTED ONLY TO THE TYPE OF GAS IDENTIFIED ON THIS RATING PLATE!

PRE-INSTALLATION: Safe and satisfactory operation of a PAR-2-20F CE gas fryer depends on its proper installation. Installation must conform to local codes.

CLEARANCES: The appliance must be kept free and clear of all combustibles. The minimum clearance from combustible and non-combustible construction is 6" (152 mm) from the sides, and 6" (152 mm) from the rear. The fryer may be installed on combustible floors.

NOTE: Adequate clearances must be provided for servicing and proper operation.

STANDARDS: Installation must be planned in accordance with all applicable National and local codes, taking into account the following standards:

- A. The fryer and its individual shut-off valve must be disconnected from the gas supply piping system during any pressure testing of that system at pressures in excess of ½ psig (3.45kPa).
- B. The fryer must be isolated from the gas supply piping system by closing its individual manual shut-off valve during any pressure testing of the gas supply piping system at pressures equal to or less than ½ psig (3.45kPa).
- C. When installed the fryer must be electrically grounded in accordance with local codes.
- D. Exhaust hood, when installed must conform to the local codes.

NOTE: Local building codes will usually not permit a fryer with its open tank of hot oil to be installed immediately next to an open flame of any type, whether a broiler or an open burner or range. Check local codes before beginning installation.

AIR SUPPLY AND VENTILATION: The area around the appliance must be kept clear of any combustible or flammable products and avoid any obstruction to the flow of ventilation air as well as for ease of maintenance and service. **NOTHING** is to be stored in the interior of the fryer's cabinet except the filter tub assembly.

- A. A means must be provided for any commercial, heavy duty-cooking appliance to exhaust combustion wastes outside of the building. It is essential that a fryer be set under a powered exhaust hood or that an exhaust fan be provided in the wall above the unit, as exhaust temperatures are in the vicinity of 400°F (204°C).

NOTE: Strong exhaust fans in a hood or in the overall air conditioning system can produce slight air drafts in the room, which can interfere with burner performance and be hard to diagnose. Air movement should be checked during installation and if burner problems persist, make-up air openings or baffles may have to be provided in the room.

- B. Exhaust temperature, in addition to the open tank of hot oil, make the storage of anything on shelving over or behind the fryer unsafe.
- C. Filters and drip troughs should be part of any industrial hood, but consult local codes before constructing and installing any hood.
- D. Provisions must be made for an adequate supply of fresh air and adequate clearance must be maintained for air openings into the combustion chamber.

RECEIVING & INSTALLING THE FRYER

UNPACKING: Check that the container is upright. Use an outward prying motion – **DO NOT USE A HAMMER** - to remove the carton. Check the fryer(s) for visible damage; if such damage has occurred do not refuse shipment, but contact the carrier and file the appropriate freight claims. Remove the two shipping bolts in the front and rear legs and remove the two (2) 2" x 6" (51 x 152mm) wood supports.

INSTALLING:

WARNING: IMPROPER INSTALLATION, ADJUSTMENT, ALTERATION, SERVICE OR MAINTENANCE CAN CAUSE PROPERTY DAMAGE, INJURY OR DEATH. READ THE INSTALLATION, OPERATING AND MAINTENANCE INSTRUCTIONS THOROUGHLY BEFORE INSTALLING OR SERVICING THIS EQUIPMENT. PARTS AND ADJUSTMENTS PROTECTED AND SEALED BY THE MANUFACTURER OR THEIR AGENT ARE NOT TO BE ADJUSTED BY THE USER.

- A. If sufficient clearance is available to roll the assembled fryer bank into the building, proceed to the **LEVELING** paragraph below.
- B. In the event entrance doors are too narrow for the assembled fryer bank, disassemble and reassemble the fryer as follows:

1. DISASSEMBLY

- a. Perform these steps facing the **FRONT** of the fryer:

- 1) Number each vat cabinet from **LEFT to RIGHT** and place these numbers on the front and rear panel of each cabinet.
- 2) Lower the Temperature Control access panel from each vat cabinet.
- 3) **CAREFULLY** remove the **APRON** from the fryer bank as follows: **TAKE CARE TO NOT DAMAGE THE GASKETS BENEATH THE APRON.**

- a) **CAREFULLY** remove the $\frac{1}{4}$ -20 wing nut, $\frac{1}{4}$ " (6mm) split lock washer and $\frac{1}{16}$ " (17mm) flat washer from each $\frac{1}{4}$ -20 weld stud beneath each vat hat sections.

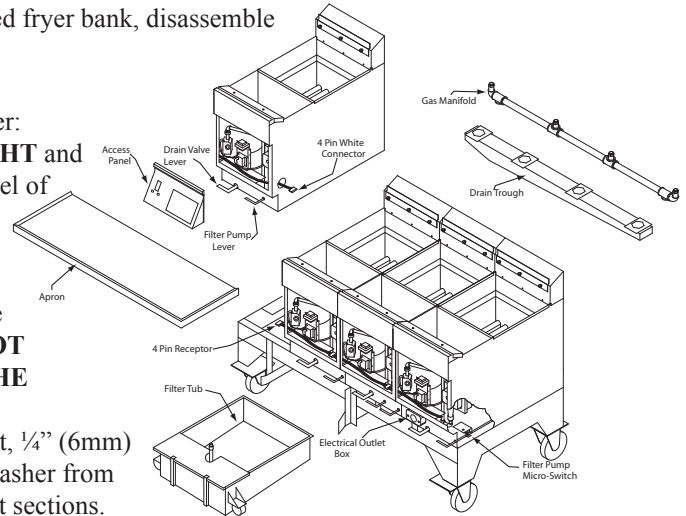

NOTE: There are two (2) weld studs located in the rear hat section and two (2) studs in the front hat section.

After all wing nuts and washers have been removed, begin **LIFTING** the apron **FRONT** flange **EVENLY** along the length of the apron.

- b) When the **FRONT** flange of the apron has been separated equal distance from each vat, continue to raise the apron while keeping it level until the **REAR** flange can be separated from the front lip of the fryer vats.
- 4) Remove the **JOINER STRIP** located between each set of Vats; then cut the **SILICONE SEAL** between the vats.
- 5) **CAREFULLY** separate the **SHORTENING DRAIN TROUGH** from each ball valve plate by removing the four (4) $\frac{1}{4}$ -20 hex head bolts and nuts; then remove the drain trough from the fryer.

NOTE: A neoprene gasket was placed between the ball valve and drain trough opening of each vat and sealed with silicone. Therefore it may be necessary to use a sharp instrument to separate the trough from the valve.

TAKE CARE NOT TO DAMAGE THE GASKET.

- 6) **CAREFULLY** disconnect the **4 PIN WHITE** connector from its mating receptacle located on the **LOWER** right hand end of each vat; then remove the **BLACK** wiring harness protector from the 2" (51mm) opening in each vat.
 - 7) **CAREFULLY** disconnect the **ELECTRICAL OUTLET BOX BLACK** and **WHITE** electrical wires connected to wires by **WIRE NUTS** located on the **LEFT HAND** side of the "extreme" **RIGHT HAND** vat.
 - 8) Remove the 10-24 truss head screw and nut on the right hand side of each vat used to secure adjoining vats and remove the 10-24 truss head screw and nut that secures the "extreme" left hand vat cabinet of the base frame.
- b) Perform these steps facing the **REAR** of the fryer:
- 1) Remove the **REAR** panel from each vat by removing the eight (8) pan head self-tapping screws from the panel and fan cover.
 - 2) Remove the two (2) 10-24 truss head screws and nuts on the right hand side of each vat used to secure adjoining vats.

- 3) **CAREFULLY** remove the two (2) self-tapping philips head screws along the **BOTTOM** flange of each cabinet.
- 4) **CAREFULLY** loosen and separate the flexible gas line from the gas manifold flare fitting on each vat, remove the ¼ -20 hexhead bolts and nuts from each manifold “**L**” **BRACKET**; then set the **GAS MANIFOLD** aside.
- 5) **CAREFULLY** disconnect the **SHORTENING LINE RED** and **WHITE** heater wires terminated in a **2 PIN WHITE** connector from its mating receptacle located on the left hand side of the “extreme” **LEFT HAND** vat.

NOTE: BLACK and WHITE CABLETYES may have to be removed to separate connections.

- 6) **CAREFULLY** disconnect the **FILTER PUMP MOTOR RED, GREEN** and **WHITE** electrical wires terminated in a **4 PIN WHITE** connector from its mating receptacle located on the left hand side of the “extreme” **LEFT HAND** vat.
- 7) **CAREFULLY** disconnect the **POWER LINE BROWN** and **BLUE** electrical wires terminated in a **4 PIN WHITE** connector from its mating receptacle located on the left hand side of the “extreme” **LEFT HAND** vat.
- 8) **SECURE** the **SHORTENING LINE** to the base frame on the **LEFT HAND** end of the fryer bank; then **CAREFULLY** loosen and separate the shortening line union attached to each ½” (13mm) ball valve.
- 9) **CAREFULLY** remove each cabinet from the base frame, carry each cabinet into the building; then place the base frame into position in the kitchen.
- 10) **PRIOR** to re-assembling the fryer bank:
 - a) Remove **DRIED** silicone used to seal the apron to vats, opening between each set of vats, front and rear of each cabinet, lower edge of the two (2) end vats and perimeter of the base frame.
 - b) **THOROUGHLY** clean the **TEFLON TAPE** from all **GAS** and **SHORTENING** fittings and pipes, then wrap all male pipes and fittings with **NEW** teflon tape.

2. RE-ASSEMBLY

- a. Place each vat cabinet in numerical order in **FRONT** of the base frame from **LEFT** to **RIGHT**.
- b. Install each vat cabinet on the base frame as follows:
 - 1) Place a bead of silicone around the perimeter of the base frame for the **FIRST** vat cabinet.
 - 2) **CAREFULLY** place **VAT CABINET #1** in position on the base frame; then secure the cabinet to the base frame by installing a 10-24 truss head screw and nut on the left hand flange to the base frame then install two (2) self-tapping philips head screws in the two holes on the bottom flange of the cabinet.
 - 3) Repeat the above procedures to install remaining vat cabinets on the base frame.
- c. When all vat cabinets are installed on the base frame, secure the cabinets as follows:
 - 1) Place a bead of silicone along the **FRONT, TOP** and **REAR** space between vat cabinets #1 and #2.
 - 2) Install a 10-24 truss head screw and nut in the ¼” (6mm) holes on the **FRONT** right hand side of vat cabinet #1 and left hand side of vat cabinet #2.
 - 3) Install two (2) 10-24 truss head screws and nuts in the two (2) 3/16” (5mm) slotted holes on the **REAR** left hand side of vat cabinet #1 used to secure it to cabinet #2.
 - 4) Repeat the above procedures to secure remaining vat cabinets to adjoining vat cabinets.
- d. Perform these steps facing the **REAR** of the fryer:
 - 1) **CAREFULLY** connect each shortening line union **HAND TIGHT**, remove the device used to secure the **SHORTENING LINE** to the **LEFT** end of the base frame; then **SECURELY** tighten each shortening line union.
 - 2) Place the **GAS MANIFOLD** in position, secure each manifold “**L**” **BRACKET** to the frame using the ¼-20 hex head bolts and nuts removed earlier; then **SECURELY** connect each manual gas valve flexible gas line to the male flare fitting on the manifold.
 - 3) **SECURELY** connect the **SHORTENING LINE RED** and **WHITE** heater tape electrical wires terminated in a **2 PIN WHITE** connector to its mating receptacle on the left hand side of the “extreme” **LEFT HAND** vat. Install a small cabletye on the connection to assure these connectors cannot be separated.
 - 4) **SECURELY** connect the **FILTER PUMP MOTOR RED, GREEN** and **WHITE** electrical wires terminated in a **4 PIN WHITE** connector to its mating receptacle located on the left hand side of the “extreme” **LEFT HAND** vat.
 - 5) **SECURELY** connect the **POWER LINE BROWN** and **BLUE** electrical wires terminated in a **4 PIN WHITE** connector to its mating receptacle located on the left hand side of the “extreme” **LEFT HAND** vat.
 - 6) Install a large cabletye on the cable harness on the “extreme” **LEFT** and **RIGHT** vats; then replace the **REAR PANEL** on each vat cabinet using eight (8) pan head self-tapping screws in the cabinet panel and fan cover.
- e. Perform these steps facing the **FRONT** of the fryer:
 - 1) Install the **BLACK** wiring harness protector in the 2” (51mm) opening of each vat; then **SECURELY** connect the **4 PIN WHITE** wiring harness connector to its mating receptacle on each vat.
 - 2) **CAREFULLY** connect the **ELECTRICAL OUTLET** box **BROWN** and **BLUE** wires on the “extreme” right hand vat to the **POWER** line **BROWN** and **BLUE** wires using the wire nuts previously removed.

- 3) Remove any dried silicone from the shortening **DRAIN TROUGH**, place a bead of silicone to the same location on the drain trough, position the drain trough beneath the fryer; then **SECURE** the drain trough to each ball valve plate using four (4) ¼ -20 hex head bolts and nuts previously removed.
- 4) Remove any dried silicone from each **JOINER STRIP**, place a bead of silicone in each strip; then place the joiner strip over the edge of all adjoining fryer vats.
- 5) **CAREFULLY** replace the **APRON** as follows:
 - a) Remove any dried silicone from the upper front corner area of each vat divider, upper inside edge of each vat and the **TOP** surface of the rear hat section of each vat using alcohol.
 - b) Place the apron in position along the **REAR** of the fryer with the front of the apron elevated about 45°, seat the rear flange of the apron over the front inside edge of each vat; then **CAREFULLY** lower the front of the apron until each ¼ -20 weld stud is seated in the notches of the front and rear hat section of each vat. Slip the apron slightly to the left and right to center it on the fryer.
 - c) When the apron is properly positioned, secure it to the hat sections of each vat using the wing nut, split washer and flat washers removed earlier.
 - d) After the apron has been secured to each fryer vat, place a bead of silicone sealant along the seam of the apron rear flange, front panel of each vat and each vat corner and apron seam as shown below.
- 6) Raise the Temperature Control Access Panel.

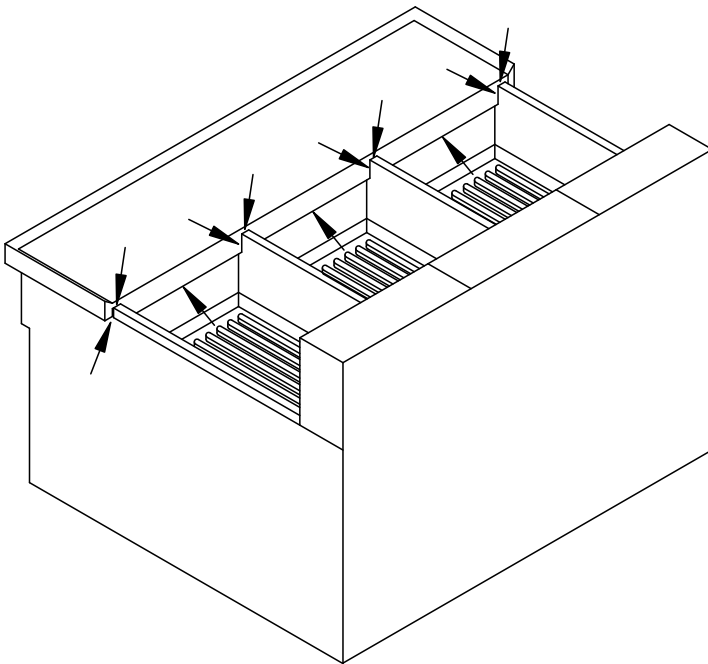

CAUTION: FAILURE TO SEAL THESE AREAS WILL PERMIT HOT SHORTENING TO PERMIATE INTO THE SPACE ALLOWING OIL TO SEEP INTO THE FIREBOX AREA.

LEVELING

- A. Roll the fryer to its operating location and check to be sure it is level at this location. If not, loosen the casters and insert the appropriate number of shim plates between leg and caster plates then retighten the caster bolts.
- B. If the floor is smooth and level, adjust to the high corner and measure with a spirit level. If the floor is uneven or has a decided slope, level the unit with metal shims.

NOTE: A caster may not return exactly to the same position after being moved, which may require re-leveling after each move.

- C. Connect the gas manifold to the building gas supply line by means of a CSA International APPROVED flexible gas line as shown in the figure below.

NOTE: CONNECT-IT inc. ¾" (19mm), 1" (25mm) and 1 ¼" (32mm) flexible gas hose 4 feet long (1219mm) with a quick disconnect coupling on one end is available from Ultrafryer Systems under PN 24-322 (¾" (19mm) hose), PN 24-323 (1" (25mm) hose) and PN 24-456 (1 ¼" (32mm) hose). These hoses are equipped with a fusible link, which melts at **361°F (183°C)** that will **SHUT OFF** the gas supply when it melts. A restraining device 44" (1119mm) long is also available under PN 24-324.

CAUTION: THE BUILDING GAS SUPPLY LINE MUST BE SIZED TO PROVIDE THE VOLUME OF GAS REQUIRED FOR PROPER OPERATION AS EXPLAINED IN THE EUROPEAN PRESSURES, GASES & SPECIAL CATEGORIES TABLE ON PAGE 4.

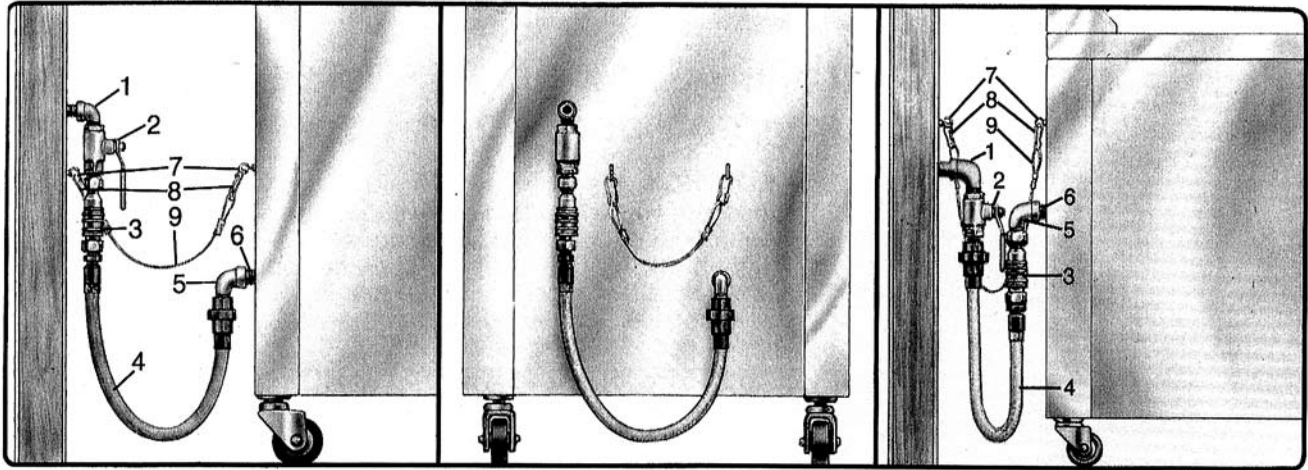

WARNING: THE RESTRAINT DEVICE (ITEM 9) MUST BE INSTALLED TO ASSURE TENSION CANNOT BE PLACED ON THE FLEXIBLE GAS LINE OR FITTING.

- | | |
|--------------------------------|------------------------------|
| 1. BUILDING GAS SERVICE LINE | 6. APPLIANCE MANIFOLD/NIPPLE |
| 2. MAIN GAS CUT-OFF VALVE | 7. EYELET FASTENERS |
| 3. CONNECT-IT QUICK-DISCONNECT | 8. SPRING HOOK |
| 4. FLEX-CON CONNECTOR | 9. RESTRAINING CHAIN |
| 5. ELBOW | |

**TYPICAL GAS CONNECTION
FIGURE 2**

INLET GAS REQUIREMENT

WARNING: IF THE “INLET” GAS PRESSURE AT THE FRYER’S COMBINATION GAS CONTROL VALVE “EXCEEDS” ½ lb/in² (.035 kg/cm²) OR APPROXIMATELY 14” (356 mm) W.C., AN EXTERNAL REGULATOR MAY BE NEEDED TO PREVENT DAMAGE TO THE COMBINATION GAS VALVE, AND VOIDING OF WARRANTY. FAILURE TO ADDRESS THIS COULD RESULT IN EXPLOSION OR FIRE..

PERTINENT GAS DATA - SEE EUROPEAN PRESSURES, GASES & SPECIAL CATEGORIES TABLE ON PAGE 4

GAS CONNECTION: The gas supply (service) line must be the same size or greater than the inlet line of the appliance. **THE GAS SUPPLY LINES MUST BE SIZED TO ACCOMMODATE ALL THE GAS FIRED EQUIPMENT THAT MAY BE CONNECTED TO THAT SUPPLY.**

NOTE: Sealant used on all pipe joints must be resistive to butane and propane gas.

- A. Manual shut off valve: This supplier-installed valve must be installed in the gas service line ahead of the appliance and in a position where it can be reached quickly in the event of an emergency.
- B. Pressure regulator: All commercial cooking equipment must have a pressure regulator on the incoming service line for safe and efficient operation, because service pressure may fluctuate with local demand. External regulators are not required on this fryer, as that function is performed by a combination gas control valve, however if the incoming pressure is in excess of ½ psig, a step-down regulator will be required.
- C. Natural gas: Natural gas fryers require 7” (178mm) water column (W.C.) “inlet” pressure to the fryer’s combination gas control valve for proper operation, when all gas units are operating simultaneously. Butane and Propane gas fryers require 14” (356mm) water column (W.C.) “inlet” pressure to the fryer’s combination gas control valve for proper operation, when all gas units are operating simultaneously. This “inlet” pressure **MUST** be checked with a manometer **PRIOR** to placing the fryer in operation.

- D. Combination gas control valve: The correct combination gas control valve and orifice is installed at the factory for **BUTANE, NATURAL and PROPANE** units based on each Purchase Order. This valve should be **CHECKED/ADJUSTED** by qualified service personnel using proper test equipment for the “**OUTLET**” gas pressure as shown in the European Gases, Pressures, and Special Categories Table on page 4 **PRIOR** to start-up of a fryer.
- E. Rigid connections: Check any installer-supplied intake pipe(s) visually and/or blow them out with compressed air to clear dirt particles, threading chips or any other foreign matter before connecting to the service line as these particles may clog the orifice when gas pressure is applied. All connections must be tested with a soapy solution before lighting the fryer. **DO NOT USE AN OPEN FLAME TO CHECK FOR LEAKS!** Putting an open flame beside a new connection is not only dangerous, but will often miss small leaks that a soapy solution would find.
- F. Flexible Couplings, Connectors: The installation is to be made with a connector that (1) complies with the quick-disconnect device established by ANSI Z21.41 (CAN1-6.9) (2) adequate means Must be provided to limit the movement of the appliance without depending on the connector and the quick disconnect device or its associated piping to limit the appliance movement and (3) the location(s) where the restraining means may be attached to the appliance shall be specified. **DOMESTIC CONNECTORS ARE NOT SUITABLE!!!**
- G. Fryer Service: The fryer is equipped with swivel casters. To service the fryer:
 1. Turn “OFF” gas supply at the supply source.
 2. Disconnect the flexible gas line quick-disconnect
 3. Disconnect restraint means and roll fryer out for rear service access.
 4. When the fryer is re-positioned, be sure to reconnect the restraint and level the fryer.

ELECTRICAL CONNECTION : The **MAXIMUM** current draw in a vat at **START-UP** or a **WARM-UP** cycle will be 0.5 amperes at 230 Volts. When running the filter system, simultaneously, with a start-up/warm-up, the current draw will increase to 5.6 amperes at 230 Volts. Internal electrical connections are in compliance with the current National Electrical Code. External electrical connections **MUST** be in compliance with National and local codes. Electrical receptacles and plugs installed by local electricians **MUST** meet the requirements of the National and local codes and **MUST** be **ACCESSIBLE** to operators of the Model PAR-2-20F CE gas fryer.

START-UP

Each Model PAR-2-20F CE gas fryer is tested, adjusted and calibrated prior to shipment; however adjustment may be necessary on installation to meet local conditions, low gas pressure, differences in altitude, variations in gas characteristics, and to correct possible problems caused by rough handling or vibration during shipment. Initial calibration or adjustment is the responsibility of the customer and will not be covered by the Ultrafryer Limited Warranty.

TO TEST OPERATE an Ultrafryer Gas Fryer equipped with an Ultrastat 21 Cooking Computer:

1. Ensure the fryer’s power ON/OFF Switch is in the OFF position.
2. Fill the fryer vat with hot or cold water to the middle of the “E<--” in the word **LEVEL** of the applicable shortening level mark on the rear of the vat.
3. Turn the **MANUAL** gas valve to the **OFF** position and wait **FIVE (5)** minutes for any accumulation of gas to disperse.
4. **ENSURE** the **MAIN** gas shut-off valve is in the **ON** position, and that the **EXHAUST FAN** is **ON**.
5. Turn the **MANUAL GAS VALVE** to the **ON** position.
6. Perform the following steps, on the following page in the order listed:

**RED
HANDLE
MANUAL
GAS VALVE**

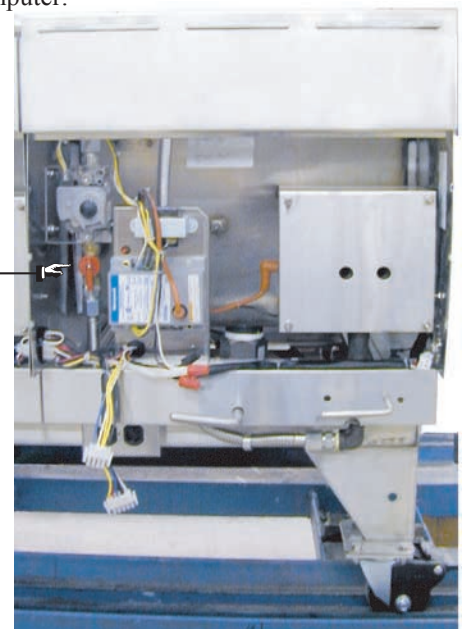

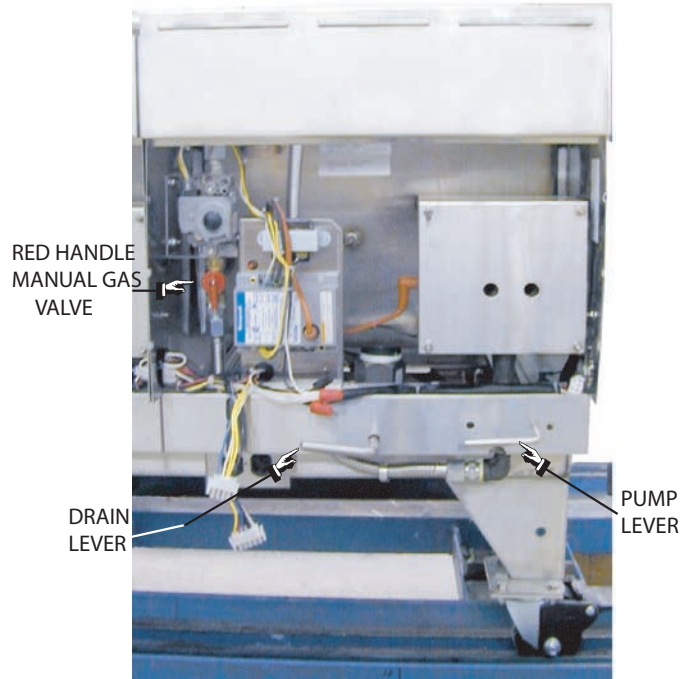
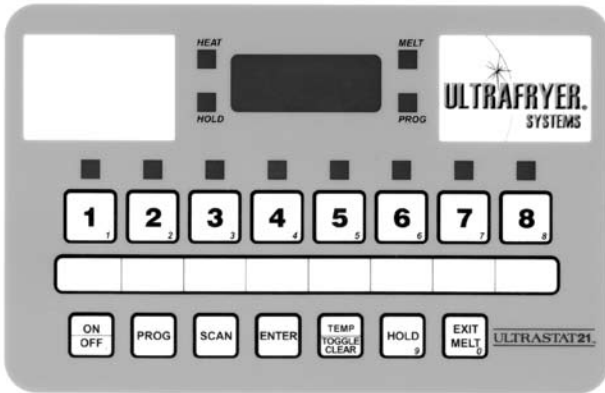

<u>STEP</u>	<u>ACTION</u>	<u>RESPONSE</u>
1	ENSURE the drain valve lever is in the closed position and that water is at the proper level; then turn the Toggle ON/OFF switch to the ON position. CAUTION: PRIOR TO PROCEEDING TO STEP 2, VISUALLY CHECK THAT THE HEAT EXCHANGERS TUBES ARE COVERED BY AT LEAST 2" (51 mm) OF WATER.	The AMBER power lamp beside the fryer Toggle ON/OFF switch will LIGHT .
2	Turn the Computer ON by depressing the Computer ON/OFF button; then place the computer in the BOIL MODE by pressing the computer keys in the following order: PROG , 1 , 7 , 3 , 3 , ENTER .	A. BOIL will appear in the computer display. B. The HEAT lamp on the computer and the RED burner indicator lamp on the fryer will cycle ON and OFF to heat the water to 190°F (88°C) .
3	When the water begins to BOIL , press the following computer keys in the order shown to EXIT THE BOIL MODE: PROG , 1 , 7 , 3 , 3 , ENTER .	A. LO will appear in the computer display. B. The HEAT lamp on the computer will turn OFF . C. The MELT lamp on the computer will LIGHT .
4	Turn the computer OFF by depressing the ON/OFF button; then turn the fryer Toggle ON/OFF switch to the OFF position.	A. The computer display will go BLANK . B. The AMBER POWER lamp will turn OFF .
5	After the water in the vat and metal surfaces of the fryer has COOLED , drain the water into a floor drain.	

INITIAL CLEANING

New Model PAR-2-20F CE gas fryers are wiped clean with solvents at the factory to remove any visible signs of dirt, oil, grease, etc., remaining from the manufacturing process; then given a light coat of oil. Each fryer and filter system should be **THOROUGHLY** washed with **HOT** sanitized solution to remove film residues, installation dust or debris and then wiped dry prior to placing the fryer into operation.

SHORTENING INSTALLATION

- A. **LIQUID SHORTENING:** When using liquid shortening (cooking oil) fill the fryer with shortening even with the middle line of the **E ←** in the word **LEVEL** of the applicable shortening level mark on the rear wall of the fryer.
- B. **SOLID SHORTENING:**
- 1) Cut a block of solid shortening into small pieces.
 - 2) Place small pieces of solid shortening **EVENLY** on top of the **HEAT EXCHANGER TUBES** or **THOROUGHLY PACK** these pieces of solid shortening between, below and above the **HEAT EXCHANGER TUBES**. While packing solid shortening is messy and time consuming, it is the fastest and safest way to melt solid shortening.
 - 3) Ultrastat 21 equipped Fryer:
 - a) Turn the fryer Toggle ON/OFF switch **ON**; then place the computer in the **SHORTENING MELT MODE** by depressing the ON/OFF button. The **MELT** lamp will **LIGHT** to indicate the computer is in the **SHORTENING MELT MODE**; and the **HEAT** lamp and **RED** burner indicator lamp on the fryer will cycle **ON** and **OFF** indicating the burner is periodically being turned **ON** and **OFF** to gently heat the shortening.
 - b) When the heat exchanger tubes are **COMPLETELY** covered with **LIQUID** shortening and the shortening is **ABOVE** the Melt Limit Temperature, replace the grill in the fryer vat; then push the **EXIT MELT** button on the computer.
 - 4) Continue adding solid shortening as follows:
 - a) Place small pieces of solid shortening into a fry basket.
 - b) **CAREFULLY** lower the basket into the fryer vat.
 - c) **GENTLY** turn the basket to allow these pieces of solid shortening to float away.
 - d) Repeat the above steps until liquid shortening is even with the middle line of the “**E←**” in the word **LEVEL** of the applicable shortening level mark on the rear wall of the fryer vat.

**WARNING!!!
TO AVIOD INJURY**

- I DO NOT MOVE A FRYER FILLED WITH HOT LIQUID.**
- II DO NOT GO NEAR THE AREA DIRECTLY OVER THE FLUE OUTLET WHEN THE FRYER’S MAIN BURNERS ARE OPERATING.**
- III ALWAYS WEAR OIL-PROOF, INSULATED GLOVES WHEN WORKING WITH A FRYER FILLED WITH HOT OIL.**
- IV ALWAYS DRAIN HOT OIL INTO A METAL TUB, POT OR CAN ... HOT OIL CAN MELT PLASTIC BUCKETS OR SHATTER GLASS.**

**PREVENTIVE MAINTENANCE,
TROUBLESHOOTING
& CLEANING**

PREVENTIVE MAINTENANCE

Minimal maintenance is required on a MODEL PAR-2-20F CE gas fryer because of its design and materials used in manufacture.

However, some preventive maintenance and inspection must be performed periodically to prevent break downs which could curtail food sales. Any preventive maintenance or inspection should be accomplished with **CAUTION** while the fryer is in operation since **HOT** liquid shortening could cause severe burns. If service or repair is required, all gas and electrical power

PREVENTIVE MAINTENANCE SCHEDULE

<u>ITEM</u>	<u>DAILY</u>	<u>INSPECT FOR:</u>
Grease Filters		Clean grease filters in the exhaust hood each evening and allow them to dry overnight.
Filter Tub		Thoroughly clean the filter tub assembly each evening and allow each item to air dry overnight.
		ENSURE THE WASH DOWN HOSE IS HUNG IN AN UPRIGHT POSITION, FROM ONE END, SO SHORTENING CAN DRAIN INTO A CONTAINER!
	<u>WEEKLY</u>	
Drain/Filter Pump Valve Levers		Determine that the drain and filter pump levers are securely attached to the drain and filter pump valves, and that the valve can be easily opened and closed.
Drain Hoses		Inspect the suction line hose, wash down hose and if applicable the shortening disposal hose for any evidence of deterioration.
Plumbing Heat Tape Insulation		Ensure that insulation and electric heat tape wrapped around the plumbing directly behind the drain trough has not been damaged.
Temperature Sensing Probes		During boil-out of the fryer, inspect the temperature and high limit sensing probes for any visual damage.

TROUBLESHOOTING

- 1 GENERAL:** The problems and possible solutions listed in the troubleshooting chart below are typical Problems that are frequently encountered. **ONLY** qualified repairmen are to use the troubleshooting chart to repair this fryer. In the event a main burner malfunction occurs, perform the following checks **PRIOR** to contacting a repairman:
 - Ensure Gas Valves are in their proper position.
 - Check that the fryer electrical plug is connected to an electrical receptacle.
 - Ensure the applicable Circuit Breaker is in the **ON** position and that the Toggle ON/OFF Switch is in the **ON** position.
 - Ensure the gas supply line quick-disconnect coupling is **SEATED** on the gas manifold fitting.
 - Determine that the blower is operating.
- 2 TROUBLESHOOTING CHART:** Should a problem occur that cannot be corrected after performing the above **CHECKS**, contact an authorized repairman and/or Ultrafryer Systems Customer Service at 1-800-525-8130 and provide the information acquired while performing these checks.

CAUTION: ENSURE REPAIRMEN ARE ADVISED THAT FRYER RESTRAINTS MUST BE DISCONNECTED/CONNECTED IF A FRYER IS TO BE MOVED DURING MAINTENANCE OR REPAIR AND THAT ELECTRICAL POWER AND GAS MUST BE TURNED OFF PRIOR TO PERFORMING ANY MAINTENANCE OR REPAIR.

TROUBLESHOOTING CHART

<u>PROBLEMS</u>		<u>POSSIBLE SOLUTIONS</u>	
A	Main burner will not ignite. Blower is operating; but gas is not present at the burner.	1	Check the Blower Motor air pressure Switch by temporarily disconnecting the two (2) ORANGE blower motor wires and connecting them together. If the IGNITOR sparks when these wires are connected, the air pressure switch is defective and it will have to be replaced.
		2	Check the following components and replace if found to be defective: Transformer Gas Control Valve Hi-Limit Switch
B	Electrical power is present at the fryer, but the Blower is not operating.	1	Blower Motor may have over-heated and shut-off on thermal overload. If this situation did occur, it will correct itself when the motor cools (10-20 minutes). If this overheating problem persists, replace the blower motor.
C	Excessive time is required to raise the shortening to cooking temperature. Temperature recovery is slow and main burner flames are small and appear to be lethargic.	1	Ensure that the MANUAL GAS VALVE is completely open.
		2	Check for an obstruction in the gas line.
		3	Check for an obstruction in the flue pipe.
		4	Check that the ORFICE PLUG has the correct drill size opening as indicated on the European Pressures, Gases & Special Categories Table on page ?.
		5	Check for damaged BLOWER MOTOR fins.
		6	Use a standard water-type U-gauge Manometoer to check the pressure at the gas control valve pressure tap. Proper gas pressure is indicated on the operational requirements comparison chart shown on next page. NOTE: If necessary remove the Pressure Regulator Adjustment cover and adjust this control to the proper pressure. (Turn adjusting screw CLOCKWISE to increase gas pressure to the burner and COUNTER CLOCKWISE to decrease gas pressure. Replace adjustment cover.)
D	Shortening temperature is too high and breaks down quickly.	1	Check the gas pressure as described above.
		1	Insure the filter pump micro-switch is good, then check the manual reset button on the filter pump motor.
E	The filter pump motor fails to operate when the Filter Pump Lever Handle is placed in the OPEN position.		WARNING!!! TURN THE FILTER PUMP LEVER HANDLE TO THE CLOSED POSITION PRIOR TO DEPRESSING THE RESET BUTTON. FAILURE TO PLACE THIS HANDLE IN THE CLOSED POSITION COULD RESULT IN SEVERE BURNS FROM HOT COOKING OIL!
		2	If the filter pump motor fails to operate after the reset button has been depressed, repair or replace the motor.
F	Decreased shortening flow rate while filtering.	1	Check for excessive sediment on the filter screen, standpipe suction fitting or in the filter tub.
G	Pump / Motor operates but does not pump shoretening.	1	Check for congealed shortening in the shortening system.
		2	Check that the Standpipe is seated in the Knurl Knob.
		3	Check for loose Standpipe / Suction Line Coupler connection.
H	Pump / Motor hums but will not pump shortening.	1	Check for congealed shortening in the pump or in the shortening plumbing.

CLEANING - Any item of equipment operates better and lasts longer when it is kept cleaned and properly maintained, and the **ULTRAFRYER** and **FILTER TUB ASSEMBLY** are no exception. Clean the Ultrafryer daily and weekly according to this manual. Clean the **FILTER SCREEN** after Filtering Shortening and at Closing; and **THOROUGHLY** clean the **FILTER TUB ASSEMBLY** each **DAY** and **WEEK** as described below.

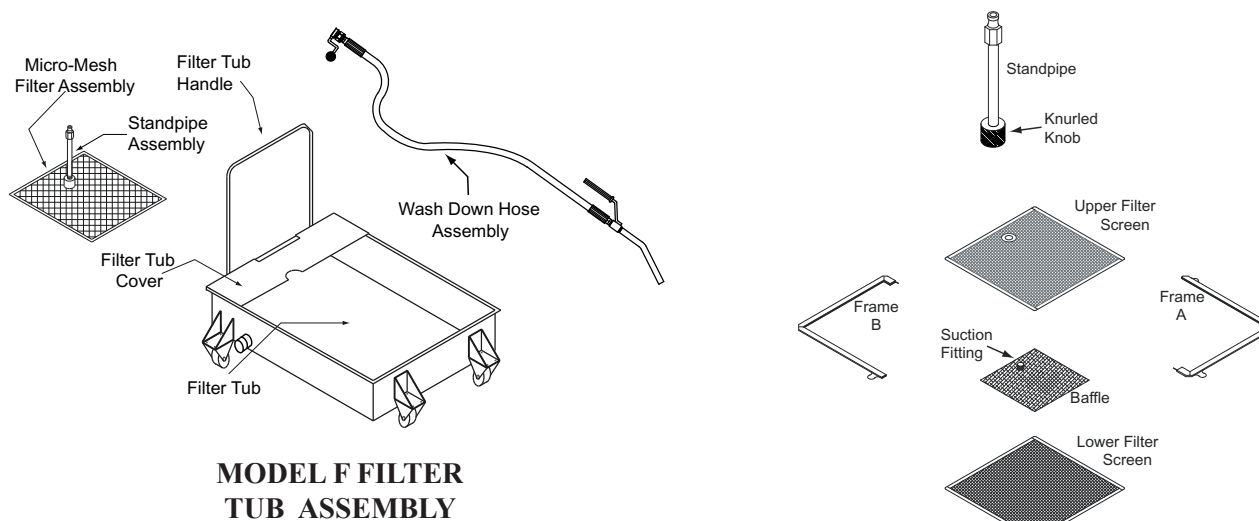

**MODEL F FILTER
TUB ASSEMBLY**

A. Daily

1. Clean the Filter Machine and Filter Assembly after **FILTERING** and **AT CLOSING** as follows:

a. After Filtering Shortening:

- 1) Disassemble the Filter Machine by removing the following items in the order listed; (1) **FILTER TUB HANDLE**, (2) **COVER**, (3) **WASH DOWN HOSE**, (4) **SUCTION LINE HOSE**, and (5) **FILTER ASSEMBLY**.
- 2) Clean the Suction Line Hose and Wash Down Hose with sanitizer solution; then hang these hoses in an upright position so any shortening can drain into a container.
- 3) Raise the Filter Assembly above the Filter Tub and let any sediment or shortening drain into the tub; then **THOROUGHLY** clean the filter assembly as follows:
 - a) **CAREFULLY** remove any debris from the screen using a scraper.
 - b) Remove the **STANDPIPE** and **KNURL** knob from the **FILTER SCREEN** assembly, grasp the **FINGER LOOP** on **FRAME A** and adjacent **FINGER LOOP** on **FRAME B**, **EVENLY** pull the frames apart; then **HINGE** **FRAME A** to remove it from the **FILTER SCREENS** **FIRST**.
 - c) Grasp the **FINGER LOOP** on the straight side of **FRAME B**; then **HINGE** it to remove **FRAME B** from the **FILTER SCREENS**.
 - d) Separate the **UPPER FILTER SCREEN** and **BAFFLE** from the **LOWER FILTER SCREEN**.
 - e) **CAREFULLY** clean the two frames, screens and baffle in the 3 compartment sink with hot water and allow these items to air dry. **DO NOT USE SOAP**. If necessary the channels in each frame can be cleaned with the edge of a scotch-brite pad.
 - f) Insert the **SUCTION FITTING** on the **BAFFLE** in the hole of the **UPPER FILTER SCREEN**; then place these items on top of the **LOWER FILTER SCREEN**.
 - g) **ENSURE** all sides of the **FILTER SCREEN** assembly are aligned, place the **PIN** end of **FRAME A** on the **FILTER SCREENS**, place the **CHANNEL** on the frame adjacent to the **PIN** end over the **FILTER SCREENS**; then **HINGE** the frame so the edge of the **FILTER SCREENS** are inserted in the other **CHANNEL** of **FRAME A**.
 - h) Place the **PIN** end of **FRAME B** on the **FILTER SCREENS** so the **PIN** is seated in the **CHANNEL** of **FRAME A** near the **FINGER LOOP**, place the **CHANNEL** on the frame adjacent to the **PIN** end over the edge of the **FILTER SCREENS**; then **HINGE** the frame so the edge of the **FILTER SCREENS** are inserted in the other **CHANNEL** of **FRAME B** and the **PIN** of **FRAME A** is seated in the **CHANNEL** of **FRAME B**.
 - i) Adjust **FRAME A** and **B** so both **PINS** are properly seated in the **CHANNEL** of the opposite frame; then **CAREFULLY** connect the **KNURL KNOB** and **STANDPIPE** to the **SUCTION FITTING** on the **FILTER SCREEN** assembly. **DO NOT OVERTIGHTEN!!!**
- 4) Remove any sediment and shortening in the Filter Tub using a scraper; then wipe the tub dry with paper towels.
- 5) Carefully insert the Filter Assembly in the bottom of the Filter Tub with the **STANDPIPE** centered in the handle end of the tub.

WARNING: WHEN ASSEMBLED, ENSURE THERE ARE NO FINGER LOOPS ON THE STANDPIPE SIDE OF THE FILTER.

- 6) Install the assembled Filter Tub Assembly on the filter tub guides beneath the fryer; then **SECURELY** connect the Suction Hose Assembly to the **STANDPIPE** on the Filter Screen and the **BULKHEAD SUCTION COUPLING** on the Fryer as shown to the right.

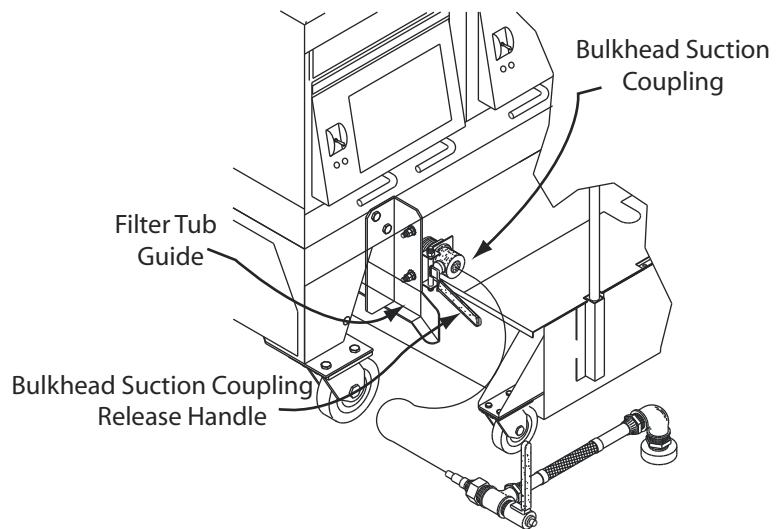
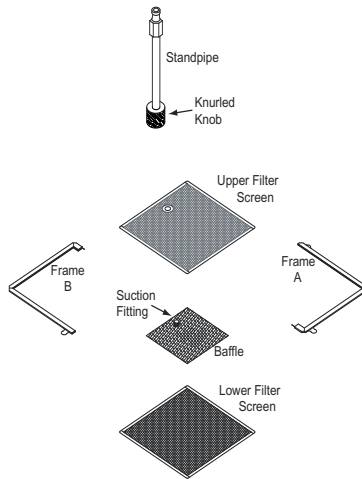

b. At Closing

- 1) Repeat **DAILY** steps A 1 a 1) thru A 1 a 3) above.
- 2) **THOROUGHLY** clean the Filter Assembly as follows:
 - a) **THOROUGHLY** flush any remaining sediment from both sides of the filter screen with **HOT WATER**.
 - b) Remove the **STANDPIPE** and **KNURL** knob from the **FILTER SCREEN** assembly, grasp the **FINGER LOOP** on **FRAME A** and adjacent **FINGER LOOP** on **FRAME B**, **EVENLY** pull the frames apart; then **HINGE FRAME A** to remove it from the **FILTER SCREENS FIRST**.
 - c) Grasp the **FINGER LOOP** on the straight side of **FRAME B**; then **HINGE** it to remove **FRAME B** from the **FILTER SCREENS**.
 - d) Separate the **UPPER FILTER SCREEN** and **BAFFLE** from the **LOWER FILTER SCREEN**.
 - e) **CAREFULLY** clean the two frames, screens and baffle in the 3 compartment sink with hot water and allow these items to air dry. **DO NOT USE SOAP**. If necessary the channels in each frame can be cleaned with the edge of a scotch-brite pad.
 - f) Insert the **SUCTION FITTING** on the **BAFFLE** in the hole of the **UPPER FILTER SCREEN**; then place these items on top of the **LOWER FILTER SCREEN**.
 - g) **ENSURE** all sides of the **FILTER SCREEN** assembly are aligned, place the **PIN** end of **FRAME A** on the **FILTER SCREENS**, place the **CHANNEL** on the frame adjacent to the **PIN** end over the **FILTER SCREENS**; then **HINGE** the frame so the edge of the **FILTER SCREENS** are inserted in the other **CHANNEL** of **FRAME A**.
 - h) Place the **PIN** end of **FRAME B** on the **FILTER SCREENS** so the **PIN** is seated in the **CHANNEL** of **FRAME A** near the **FINGER LOOP**, place the **CHANNEL** on the frame adjacent to the **PIN** end over the edge of the **FILTER SCREENS**; then **HINGE** the frame so the edge of the **FILTER SCREENS** are inserted in the other **CHANNEL** of **FRAME B** and the **PIN** in **FRAME B** is seated in the **CHANNEL** of **FRAME A**.
 - i) Adjust **FRAME A** and **B** so other **PINS** are properly seated in the **CHANNEL** of the opposite frame; then **CAREFULLY** connect the **KNURL KNOB** and **STANDPIPE** to the **SUCTION FITTING** on the **FILTER SCREEN** assembly. **DO NOT OVERTIGHTEN!!!**

B. WEEKLY

1. Perform the daily cleaning steps A 1 b 1) and A 1 b 2) above.

2. Clean the Filter Assembly as follows:
 - a) Disassemble the filter according to **DAILY** steps A 1 a 3) a) through A 1 a 3) d) and clean the two (2) frames as described in step A 1 a 3) e).
 - b) Place the upper and lower **FILTER SCREENS** in the fryer with **BOIL-OUT SOLUTION** for cleaning. **DO NOT PLACE THE BAFFLE OR STANDPIPE IN THIS SOLUTION!!!** **BOIL-OUT** the fryer vat according to instructions contained in the cleaning manual provided by your chemical supplier.
 - c) After the filter screens have been cleaned in the Boil-Out Solution, **ENSURE** they are **THOROUGHLY** sprayed with a solution of **1 PART** vinegar to **25 PARTS** of water to **NEUTRALIZE** the boil-out solution, then allow the screens to air dry.

NOTE: Any residue of boil-out solution on the filter screens could cause the rapid break-down of the shortening.

- d) Reassemble the “Micro-Mesh stainless steel filter screen according to **DAILY** steps A 1 a 3) f) through A 1 a 3) i).
3. Place the **FILTER SCREENS** and **FRAMES** in the fryer with the Boil-Out Solution for cleaning, and after they are cleaned, **ENSURE** they are sprayed with a solution of vinegar/water as described in **WEEKLY** step B2 a) 3) above.
4. **THOROUGHLY** clean the Filter Tub, Cover and Sludge Catcher Pan with **HOT SANITIZER SOLUTION** and allow them to air dry.
5. Re-assemble the Filter Tub according to **DAILY** steps A 1 a 3) g) through A 1 a 3) i) (pg 18).

WARNING: WHEN ASSEMBLED, ENSURE THERE ARE NO FINGER LOOPS ON THE STANDPIPE SIDE OF THE FILTER.

**FRYER
OPERATIONS**

1. GENERAL

The Model PAR-2-20F CE gas fryer is equipped with a “standard” Central Filtration System consisting of : 1) “Universal” Filter

Tub Assembly containing a Micro-Mesh stainless steel filter screen and wash down hose; and 2) an Ultrastat 21 Cooking Computer. The fryer Toggle ON/OFF switch, **AMBER** Power indicator lamp, **RED** Burner indicator lamp are located on the Temperature Control Access Panel on each fryer vat as shown below.

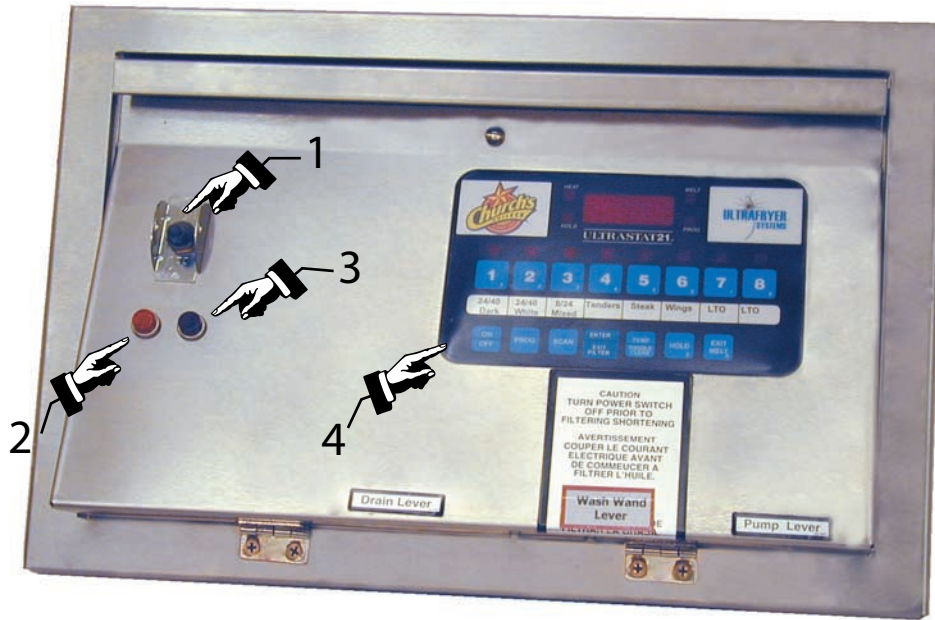

**PAR-2-20F CE GAS FRYER
CONTROL PANEL**

The Electric and Manual Gas Valves, Ignitor Module and Rod, and Hi-Limit Switch are located behind each Temperature Control Access Panel and the Filter tub Assembly is located beneath the extreme left hand fryer in a Bank of Fryers.

<u>ITEM</u>	<u>DESCRIPTION</u>
1	Fryer Toggle ON/OFF Switch
2	Amber Power Lamp
3	Red Burner Lamp
4	Cooking Computer

ULTRASTAT 21 COOKING COMPUTER

The Model PAR-2-20F CE gas fryers are equipped with an Ultrastat 21 Cooking Computer which is connected to the fryer’s electrical system to serve as its thermostat as well as providing heat control, status information and product cook timer. When the computer is in operation it will **DISABLE** the fryer if the drain valve is **OPENED**.

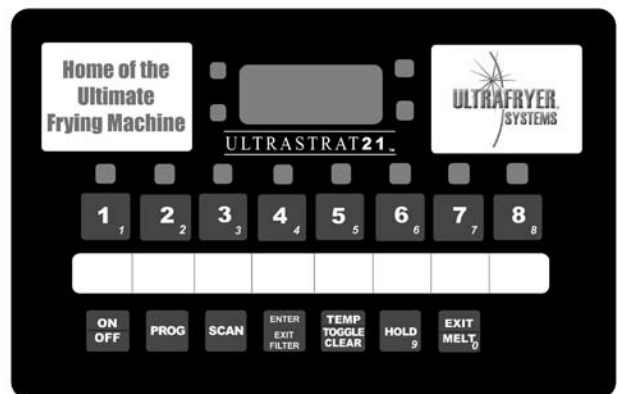

A. COMPUTER PANEL KEY DESCRIPTIONS

1. HOLD LAMP

When lit (bright) indicates a product hold time is being tracked.

2. HEAT LAMP

When lit (bright) indicates the computer is calling for heat.

3. DISPLAY

Displays modes, functions and operations of the computer.

4. MELT LAMP

When lit (bright) indicates the computer is in the melt cycle.

5. PROGRAM LAMP

When lit (bright) indicates the computer is in the program mode.

6. ON/OFF BUTTON

Turns the computer ON and OFF when the fryer power switch is in the ON position and the drain valve lever is in the closed UP position.

7. PROGRAM BUTTON

- In “operating” mode, allows access to the programming mode.
- In “programming” mode, allows access to the operating mode.

8. SCAN BUTTON

- In “operating” mode, displays the remaining cook time on every product currently in a cook cycle and lights the respective products “LED” for 2 seconds.
- In “programming” mode, steps to the next function to be programmed.

9. ENTER BUTTON

In “programming” mode, used to accept the information and “enter” it into the computer memory.

10. TEMP/TOGGLE CLEAR BUTTON

- In “operating” mode, displays the actual temperature followed by the programmed “set” temperature.
- In “programming” mode, allows the user to “toggle” (switch) between choices in an entry field and “clear” values from a data field.

11. HOLD BUTTON

- In “operating” mode, used to view remaining hold times.
- In “programming” mode used to enter numerical value 9.

12. EXIT/MELT BUTTON

- In “operating” mode, used to manually exit the shortening melt cycle.
- In “programming” mode, used to enter numerical value 0.

13. PRODUCT LED

- When lit (bright) in the “operating” mode, identifies the product data being displayed.
- When lit (bright) in the “programming” mode, identifies the product being programmed.

14. PROGRAMMING AND PRODUCT COOK BUTTON

- In “operating” mode, used to start and stop a product’s cook cycle.
- In “programming” mode, used to enter numerical values 1 to 8.

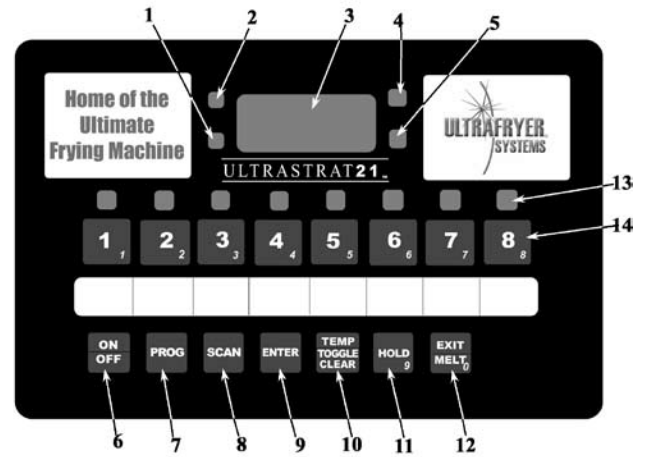

B. DISPLAY DESCRIPTIONS

Lo

The unit is in the Operating Mode. The actual vat temperature is more than 10°F (-12°C) below the programmed vat temperature.

The unit is in the Operating Mode. The actual vat temperature is within the proper cooking temperature range. The vat is ready to start a cook cycle.

Hi

The unit is in the Operating Mode. The actual vat temperature is more than 40°F (4°C) degrees above the programmed vat temperature. A continuous audible alarm sounds simultaneously.

Prob

The computer probe is either open or shorted; accompanied with an audible alarm. Check or replace the probe.

2:30

The unit is in the Operating Mode and a cook cycle is in process.

done

The unit is in the Operating Mode and a cook cycle has been completed.

Code

The unit is waiting for a pass code to be entered.

Prod

The unit is in the Product Key Programming Standby Mode.

t 1

A stage cooking time (1-10) is displayed.

tE 1

A stage cooking temperature (1-10) is displayed.

tC 1

A stage timing mode (1-10) (flex or straight) is displayed.

PrE 1

Product key action alarm programming standby mode.

PrE 1

The action alarm status is displayed.

FCYC

The unit is in Product Key Filter Lockout Programming Standby mode

F,LL

After the fryer is filtered, this display prompts you to refill the fryer with shortening.

C. ULTRASTAT 21 COOKING COMPUTER OPERATION

<u>STEP</u>	<u>ACTION</u>	<u>RESPONSE</u>
1	ENSURE the drain valve lever on the fryer is in the CLOSED position, shortening is at the proper level, the fryer TOGGLE ON/OFF switch is ON ; then depress the ON/OFF button on the Ultrastat 21 Cooking Computer.	<p>A. The AMBER POWER lamp beside the fryer TOGGLE ON/OFF switch will LIGHT.</p> <p>B. The MELT lamp will LIGHT to indicate the computer is in the SHORTENING MELT MODE.</p> <p>C. The HEAT lamp on the computer and the RED burner indicator lamp on the fryer will cycle ON and OFF indicating the burner is periodically turned ON and OFF to gently heat the shortening.</p>
<p>NOTES: 1) The computer will keep the fryer in the MELT CYCLE until the EXIT MELT button is manually depressed. 2) The computer CAN NOT be taken out of the SHORTENING MELT MODE until the shortening temperature reaches the MELT LIMIT TEMPERATURE. The Melt Limit Temperature is factory set for a HIGH exit temperature (135°F / 57°C) or a LOW exit temperature (ROOM TEMPERATURE) according to the customers specification.</p>		
2	Once the Melt Limit Temperature is reached, depress the EXIT MELT BUTTON to cancel the SHORTENING MELT MODE .	<p>A. Lo will appear in the computer display indicating shortening temperature is more than 10°F (-12°C) below the set-point temperature.</p> <p>B. The HEAT lamp on the computer and the RED burner indicator lamp on the fryer will cycle ON for 7 SECONDS and OFF for 28 SECONDS until the set-point temperature is reached.</p>
3	When ---- appears in the computer display indicating the SET-POINT TEMPERATURE of the shortening has been reached: 1) Drop the product to be cooked. 2) Depress the appropriate PRODUCT COOK BUTTON .	<p>A. The COOK time for that product will appear in the computer display and will immediately start counting DOWN.</p> <p>B. The HEAT lamp on the computer and the RED burner indicator lamp on the fryer will periodically CYCLE ON and OFF to maintain the shortening temperature as programmed.</p>
4	When time counts down to :00 indicating the programmed cook time is ended: 1) Depress the PRODUCT COOK BUTTON to turn the alarm signal OFF and reset that product cook button. 2) Remove the product from the shortening.	<p>A. done will appear in the computer display.</p> <p>B. The computer will emit an audible signal alerting the cook that the product has been cooked as programmed.</p>
5	Repeat steps 3 and 4 to cook additional product	
<p>NOTE: Steps 1, 2, 3, and 4 will have to be repeated each time any of the following occurs: DRAIN VALVE IS OPEN FRYER TOGGLE ON/OFF SWITCH IS TURNED OFF TO FILTER SHORTENING OR BOIL-OUT A FRYER FRYER TOGGLE ON/OFF SWITCH IS TURNED OFF AT CLOSING OR ANY OTHER REASON.</p>		

D. ULTRASTAT 21 COOKING COMPUTER PROGRAMING - Program the Ultrastat 21 Cooking Computer according to section IV, **Ultrastat 21 Gas Fryer Computer Operation Instruction** PN 30A009 provided with the Fryer.

CAUTION: PROGRAMMING OF AN ULTRASTST 21 COOKING COMPUTER SHOULD ONLY BE PERFORMED BY A STORE MANAGER OR AREA SUPERVISOR.

COOKING

Most products should be cooked with a shortening temperature about 360°F (182°C); however, each product should be cooked at the **LOWEST** temperature that produces a high quality product while obtaining maximum usage of the shortening.

I – DO USE A HIGH QUALITY SHORTENING TO ACHIEVE A CONSISTENT QUALITY PRODUCT AND LONG TERM SAVINGS

II – DO NOT SALT PRODUCTS OVER THE FRYER AS SALT QUICKLY DETERIORATES THE SHORTENING AND FLAVORS OTHER PRODUCTS COOKED IN THE SAME SHORTENING

III – DO FILTER SHORTENING AFTER THE LUNCH AND DINNER RUSH AND MORE OFTEN IN A HIGH SALE VOLUME STORE; AND BOIL-OUT THE FRYER EVERY 7 DAYS





ULTRASTAT 21 COOKING COMPUTER OPERATION - The following are abbreviated operating procedures for a Model PAR-2-20F CE fryer equipped with an Ultrastat 21 Cooking Computer. The attached Ultrastat 21 Ultrafryer Computer Operation Instructions PN 30A009, contains **DETAILED** Operating, Filtering, Boil-Out and Programming Instructions.

A. START-UP and COOKING

1. **ULTRASTAT 21 START-UP** - Safely start-up a gas fryer equipped with an Ultrastat 21 Cooking computer as follows:

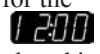
<u>STEP</u>	<u>ACTION</u>	<u>RESPONSE</u>
1	ENSURE the drain valve lever on the fryer is in the CLOSED position, shortening is at the proper level, then turn the fryer TOGGLE ON/OFF switch and, if applicable, the Gas Valve to the ON position.	A. The AMBER Power lamp beside the TOGGLE ON/OFF switch will LIGHT .
CAUTION: PRIOR TO PROCEEDING TO STEP 2 VISUALLY CHECK THAT THE HEAT MECHANISM IS COVERED WITH AT LEAST 2" (51 mm) OF SHORTENING.		
2	Turn the Computer ON by depressing the computer ON/OFF button.	A. The MELT lamp will LIGHT to indicate the computer is in the SHORTENING MELT MODE . B. The HEAT lamp on the computer and the RED heat mechanism indicator lamp on the fryer will cycle ON and OFF indicating the heat mechanism is periodically being turned ON and OFF to gently heat the shortening.
3	Once the Melt Limit Temperature is reached, depress the EXIT MELT BUTTON on the computer to cancel the SHORTENING MELT MODE .	A. LO will appear in the computer display indicating shortening temperature is more than 10°F (5°C) below the set-point temperature. B. The HEAT lamp on the computer and the RED heat mechanism indicator lamp will remain ON until the set-point temperature is reached.
4	When - - - - appears in the Computer display indicating the SET-POINT TEMPERATURE of the shortening has been reached, a COOK cycle can be initiated.	

2. **COOKING** - When the Computer is taken out of the **SHORTENING MELT MODE** each morning, shortening in the fryer vat will be heated to its **SETPOINT** temperature and “**LO**” will appear in the display to indicate the shortening temperature is **MORE** than **10°F (5°C) BELOW** the setpoint temperature. When shortening temperature rises to the **SETPOINT** temperature - - - - will appear in the display indicating a **COOK CYCLE** can be started.

a. **STARTING A COOK CYCLE**- To start a cook cycle simply press the product key for the  product you wish to cook. If the product is programmed, the correct cooking time will be displayed  (example) and this time will immediately start to count down in minutes and seconds. If  is displayed immediately and the unit starts to signal, the key being operated is not programmed. If correctly programmed, it will count down to  followed by  and start to signal. To turn this signal **OFF** and reset the Computer, press the  product key used to start the **COOK CYCLE**.

b. **CANCELLING A COOK CYCLE** - If a cook cycle was inadvertently started it may be cancelled two (2) ways:

- 1) Press and hold the same product key  used to start the cook cycle for **4 SECONDS**. This prevents an accidental cancelling of a cook cycle while a product is being cooked.
- 2) A cook cycle can be **CANCELLED** at any time by turning the Ultrafryer Toggle ON/OFF Switch to the **OFF** position.

B. FILTERING SHORTENING - Assemble the Filter Tub as described below:

1. Begin by assembling a clean “Micro-Mesh” Stainless Steel Filter Screen as follows:
 - a. Insert the **SUCTION FITTING** on the **BAFFLE** in the hole of the **UPPER FILTER SCREEN**; then place these items on top of the **LOWER FILTER SCREEN**.
 - b. **ENSURE** all sides of the **FILTER SCREEN** assembly are aligned, place the **PIN** end of **FRAME A** on the **FILTER SCREENS**, place the **CHANNEL** on the frame adjacent to the **PIN** end over the **FILTER SCREENS**; then **HINGE** the frame so the edge of the **FILTER SCREENS** are inserted in the other **CHANNEL** of **FRAME A**.
 - c. Place the **PIN** end of **FRAME B** on the **FILTER SCREENS** so the **PIN** is seated in the **CHANNEL** of **FRAME A** near the **FINGER LOOP**, place the **CHANNEL** on the frame adjacent to the **PIN** end over the edge of the **FILTER SCREENS**; then **HINGE** the frame so the edge of the **FILTER SCREENS** are inserted in the other **CHANNEL** of **FRAME B** and the **PIN** of **FRAME A** is seated in the **CHANNEL** of **FRAME B**.
 - d. Adjust **FRAME A** and **B** so both **PINS** are properly seated in the **CHANNEL** of the opposite frame; then **CAREFULLY** connect the **KNURL KNOB** attached to the **STANDPIPE** to the **SUCTION FITTING** on the **FILTER SCREEN** assembly. **DO NOT OVERTIGHTEN!**
2. Assemble the Filter Tub as described below:
 - a. Make sure all the components of the Filter Tub as seen below are clean and dry.
 - b. Reassemble the Filter Tub by replacing the components in the following sequence: 1) **FILTER ASSEMBLY**, 2) **COVER**, 3) **SUCTION LINE HOSE** and **WASH DOWN HOSE**, and 4) **FILTER TUB HANDLE**.

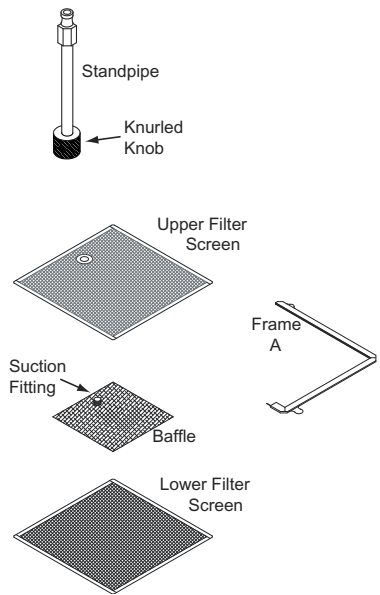

CAUTION: WHEN ASSEMBLED, ENSURE THERE ARE NO FINGER LOOPS ON THE STANDPIPE SIDE OF THE MICRO-MESH FILTER.

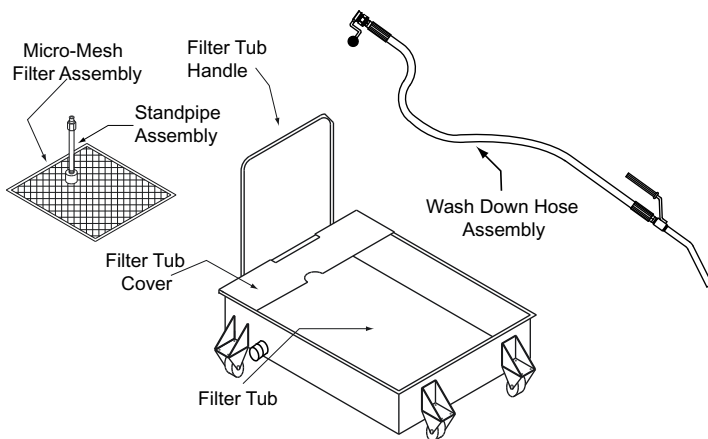

**MODEL F
FILTER TUB ASSEMBLY**

3. Position the cleaned, dry Filter tub on the **FILTER TUB GUIDES** beneath the **LEFT** side of the fryer; then **SECURELY** connect the Suction Line Hose Assembly to the **STANDPIPE** on the Filter Screen and the **BULKHEAD** Suction Coupling on the Fryer as shown to the right.

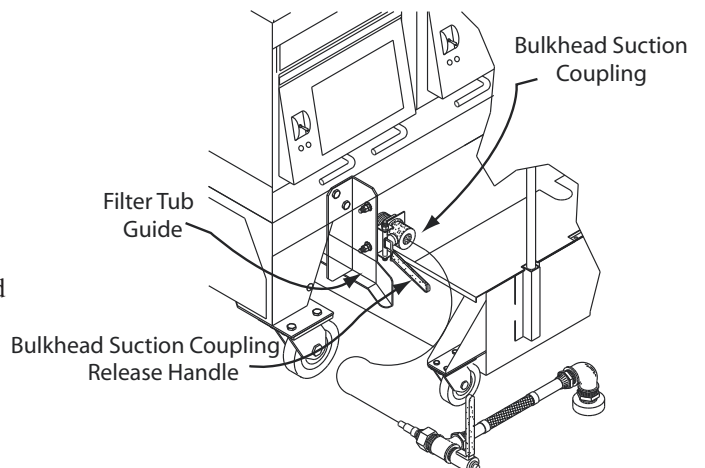

4. Turn the Toggle ON/OFF Switch on the fryer vat to be filtered **OFF**, place 16 ounces (.454 kg) by volume of **FILTER AGENT** in a 20" (508 mm) and 18" (457 mm) fryer vat; 14 ounces (.397 kg) in an 18" (457 mm) **SHALLOW** fryer vat; and 8 ounces (.227 kg) in a 14" (356 mm) fryer vat; thoroughly stir the filter agent into the shortening using the skimmer, then skim the shortening to remove any floating crumbs.

CAUTION: PRIOR TO PROCEEDING TO THE NEXT STEP, PUT ON SAFETY GOGGLES, NEOPRENE INSULATED GLOVES AND AN APRON.

5. Carefully open the drain valve on the vat to be filtered by turning the **DRAIN LEVER** slightly downward. When the bottom of the filter tub is covered with about 2" (51 mm) of shortening, **OPEN** the drain valve and slowly drain shortening to allow the heat mechanism to gradually **COOL**.
6. When all shortening in the vat has drained into the filter tub, use the **DRAIN ROD** to stand the wire grill on one side of the vat.
7. Use the drain rod to break up the sediment cake on the bottom of the vat and push it towards the Drain Opening.
8. Use a scraper to remove encrusted material from the sides of the vat and a scrubbing pad to remove carbon buildup from the top and sides of the heat mechanism.
9. **SECURELY** connect the Wash Down Hose **QUICK-CONNECT COUPLER** to the **QUICK-CONNECT STEM** on the rear wall of the vat (pull the coupler bracket with the **BLACK** knob towards the hose, place the coupler over the stem until it is **SEATED**, then release the coupler bracket). A distinct **CLICK** will be heard when the coupler seats on the stem.

CAUTION: IF THE COUPLER IS NOT SECURELY ATTACHED TO THE STEM, HOT SHORTENING WILL BE DISCHARGED AROUND THIS CONNECTION WHICH COULD CAUSE SEVERE BURNS.

10. Place the Wash Down Hose Nozzle into the vat and hold it firmly against the inner wall. This prevents the hose from "jumping" when the Filter Pump is turned on.
11. Turn the **PUMP LEVER** to the open (**DOWN**) position, hold the nozzle at a 45 degree angle from the bottom of the vat causing the shortening and debris to bounce off the rear wall of the vat and flow towards the drain valve.
12. Use the drain rod and/or "L" Shaped Brush to push the sediment through the drain valve to keep the drain clear. Hose off the Heat Mechanism and all walls of the vat until all the shortening and residue at the bottom of the vat has been flushed through the drain into the filter tub.
13. Turn the **PUMP LEVER** to the closed (**UP**) position, and then disconnect the Wash Down Hose **QUICK-CONNECT COUPLER** from the **QUICK-CONNECT STEM** on the rear wall of the vat.
14. Replace the wire grill in the fryer with the **SHORTENING DEFLECTOR** on the **RIGHT SIDE** of the vat, **COVERING** the quick-connect stem.
15. Set a Timer for for the amount of time established by your Operations Department for **POLISHING** the shortening; then turn the **PUMP LEVER** to the open (**DOWN**) position to allow shortening in the filter tub to circulate through the system.

CAUTION: DO NOT POLISH THE SHORTENING LONGER THAN THE ESTABLISHED TIME AS IT WILL PUMP EXCESS AIR INTO THE SHORTENING CAUSING SHORTENING BREAKDOWN.

NOTE: The filter pump system can **ONLY** be operated when the fryer's Toggle **ON/OFF** switch is in the **OFF** position and the filter pump lever is in the **OPEN (DOWN)** position. When the filter system is in operation, the Computer **CANNOT** be turned **ON** and the Heat Mechanism **CANNOT** be activated.

16. When **POLISHING** is complete, turn the **PUMP LEVER** and **DRAIN LEVER** to the closed (**UP**) position.
17. Turn the Pump Lever to the open (**DOWN**) position to automatically return the shortening in the filter tub to the vat.
18. When all shortening has been returned to the vat, turn the Pump Lever to the closed (**UP**) position, then **CAREFULLY** remove any sediment from the permanent filter screen using the Filter Tub Scraper.
19. Add shortening to the fryer, if applicable.
20. Repeat step 1 through 19 to filter shortening in the remaining vats.

21. When all vats have been filtered and polished, **IMMEDIATELY** hang the Wash Down Hose assembly in an upright position so shortening can drain into a container, and disconnect the **SUCTION LINE HOSE** from the **STANDPIPE**, and remove the filter tub from beneath the fryer bank.

NOTE: Failure to hang the Wash Wand Hose in an upright position to drain may cause the hose to become clogged with hardened shortening.

22. **THOROUGHLY** clean the Filter Tub Assembly according to procedure in paragraph A. page 17.

23. **RESUME NORMAL OPERATIONS** - **VISUALLY** check and if necessary, add fresh shortening to each fryer vat until shortening reaches the middle line of the “**E ←**” in the word **LEVEL** of the applicable shortening level mark on the rear wall of the fryer; then turn the Toggle ON/OFF button to the **ON** position to return to Normal Operation.

NOTE: The Drain Valve must be in the **CLOSED (UP)** position to turn the computer ON.

C. SHORTENING DISPOSAL/FRYER BOIL-OUT

1. **SHORTENING REMOVAL / DISPOSAL** - Fryer vats should be **BOILED-OUT** at least every **7 DAYS** to remove carbon build up and other encrusted materials.
 - a. If the store is equipped with a Shortening Disposal System, remove used shortening from the fryer vat that is **CLOSEST** to the Shortening Disposal System connector. If the store is **NOT** equipped with a Shortening Disposal System, remove used shortening from the first fryer vat.
 - b. Assemble the filter Tub as described on page 26, position the filter tub on the **FILTER TUB GUIDES** beneath the **LEFT** side of the fryer; then **SECURELY** connect the Suction Line Hose Assembly to the **STANDPIPE** on the Filter Screen and the **BULKHEAD Suction Coupling** on the fryer as shown to the right.
 - c. Turn the **TOGGLE ON/OFF SWITCH** and the **MANUAL GAS VALVE** to the first vat **OFF**.

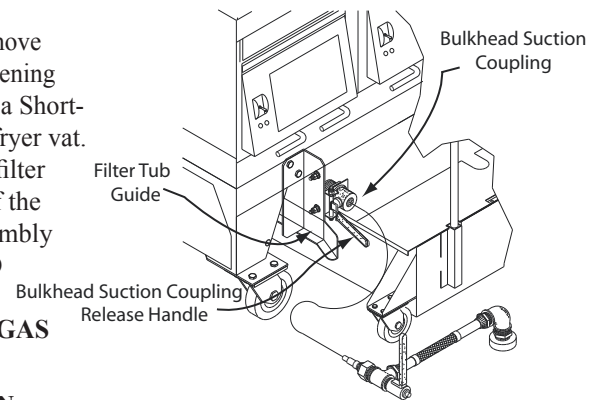

CAUTION: PRIOR TO PROCEEDING TO THE NEXT STEP, PUT ON SAFETY GOGGLES, NEOPRENE INSULATED GLOVES AND AN APRON.

- d. Turn the venthood Exhaust Fan **ON** and drain shortening from **EACH** fryer vat as follows:
 - 1) Carefully open the drain valve by turning the **DRAIN LEVER** slightly downward. When the bottom of the filter tub is covered with about 2” (51 mm) of shortening, **OPEN** the drain valve and slowly drain shortening to allow the heat mechanism to gradually **COOL**.
 - 2) When all shortening has drained into the filter tub, use the **DRAIN ROD** to stand the wire grill on one side of the vat.
 - 3) **SECURELY** connect the Wash Down Hose **QUICK-CONNECT COUPLER** to the **QUICK-CONNECT STEM** on the rear wall of the vat (pull the coupler bracket with the **BLACK** knob towards the hose, place the coupler over the stem until it is **SEATED**, then release the coupler bracket). A distinct **CLICK** will be heard when the coupler seats on the stem.

CAUTION: IF THE COUPLER IS NOT SECURELY ATTACHED TO THE STEM, HOT SHORTENING WILL BE DISCHARGED AROUND THIS CONNECTION WHICH COULD CAUSE SEVERE BURNS.

- 4) Place the Wash Down Hose Nozzle into the vat and hold it firmly against the inner wall. This prevents the hose from “jumping” when the Filter Pump is turned on.
- 5) Turn the **PUMP LEVER** to the **ON (DOWN)** position, hold the nozzle at a 45° angle from the bottom of the vat causing the shortening and debris to bounce off the rear wall of the fryer and flow towards the drain valve.
- 6) Use the drain rod to push the sediment through the drain valve to keep the drain clear. Hose off the heat mechanism and all walls of the fryer vat until all the shortening and residue on the bottom of the vat has been flushed through the drain into the filter tub.
- 7) Turn the **PUMP LEVER** and **DRAIN LEVER** to the **OFF/CLOSED (UP)** position.
- 8) Dispose of used shortening as follows:
 - a) Restaurants **NOT** equipped with a Shortening Disposal System:
 - (1) Place the Wash Down Hose nozzle into a **METAL** container and hold it firmly against an inner wall. This prevents the hose from “jumping” when the Filter Pump is turned on.
 - (2) Turn the **PUMP LEVER** to the **ON (DOWN)** position and pump shortening from the filter tub into the metal container.
 - (3) When all shortening in the filter tub has been pumped into the metal container, turn the **PUMP LEVER** to the **OFF (UP)** position and remove any sediment from the permanent filter screen using the filter tub scraper.

- (4) Repeat steps d1), d2), d3), d4), d5), d6), d7), d8) a) (1); d8) a) (2) and d8) a) (3) above to remove shortening from the remaining vats to metal containers.
- b) Restaurants **EQUIPPED** with a Shortening Disposal System:
 - (1) Remove the Wash Down Hose from the stem on the rear wall of the vat and **SECURELY** connect the Shortening Disposal Hose to the stem.
 - (2) **SECURELY** connect the fitting on the other end of the Shortening Disposal Hose to the Disposal System connector on the wall.
 - (3) Turn the Pump Lever to the ON (**DOWN**) position and pump shortening from the filter tub into the exterior rendering tank.
 - (4) When all shortening has been suctioned from the filter tub, turn the Pump Lever to the OFF (**UP**) position, and remove any sediment from the permanent filter screen using the Filter Tub Scraper.

NOTE: Leave the Shortening Disposal Hose connected to vat stem and Disposal System connector.

- (5) Repeat steps d1), d2), d3), d4), d5), d6), and d7) to drop shortening from the next vat into the filter tub.
- (6) Remove the Wash Down Hose from the stem on the rear wall of this vat; then turn the Pump Lever on the fryer **CLOSEST** to the Shortening Disposal System to the ON (**DOWN**) position to pump shortening from the filter tub into the exterior rendering tank.
- (7) When all shortening has been suctioned from the filter tub, turn the Pump Lever to the OFF (**UP**) position, and remove any sediment from the permanent filter screen using the Filter Tub Scraper.
- (8) Repeat steps d 8) b) (5), (6), and (7) above to remove shortening from the remaining fryer vats to the exterior rendering tank.
- (9) Remove the Shortening Disposal Hose/Wash Down Hose from the stem on the rear wall of the fryer and replace the wire grill in each vat with the **SHORTENING DEFLECTOR** on the **RIGHT SIDE** of the vat **COVERING** the quick-connect stem.
- (10) **IMMEDIATELY** hang the Wash Down Hose and, if applicable the Shortening Disposal Hose in an upright position and **THOROUGHLY** clean and reassemble the filter tub.

2. FRYER BOIL-OUT

- a. **BOIL-OUT** each fryer following cleaning instructions contained in the Cleaning Manual provided by your approved chemical supplier. The following are generic procedures:
 - 1) Ensure all Drain Levers are in the closed (**UP**) position, then add water to each vat until it reaches a point two **2” (51 mm) BELOW** the middle line of the “**E**” in the word **LEVEL** of the **UPPER** shortening level mark on the rear wall of the vats.
 - 2) Add the amount of **BOIL-OUT COMPOUND** in each fryer vat as prescribed in the Cleaning Manual provided by the Chemical Supplier.

WARNING: ONLY USE A COMERCIAL GRADE “NON-CHLORINE” BOIL-OUT COMPOUND!!!!

- 3) Turn the Toggle ON/OFF switch and Manual Gas valve for each fryer vat to the **ON** position; then depress the Computer ON/OFF key to the **ON** position.

NOTE: The drain lever must be in the closed **UP** position to turn the computer **ON**.

- 4) Place the Computer in the **BOIL MODE** by pressing the following Computer keys in the order shown:

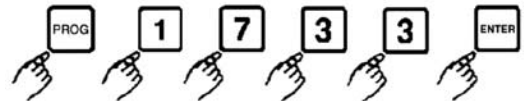

NOTE: **boil** will appear in the Computer display and the Computer will turn the Ultrafryer heat mechanism ON and OFF to heat and maintain the boil-out solution to **190°F (88°C)**.

- 5) When the boil-out solution reaches **190°F (88°C)** set a timer for 30 minutes. Frequently scrub the sides, front and rear of each fryer vat with a long handled scrub brush.
- 6) After the boil-out solution has ‘**BOILED**’ for 30 minutes and the timer sounds press the following computer keys in the order shown to **EXIT BOIL MODE**:

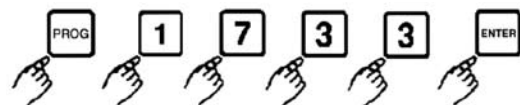

- 7) Turn the Toggle ON/OFF Switch and the Manual Gas Valve for each fryer to their **OFF** position and **CAREFULLY** dispose of the boil-out solution in each fryer into a floor drain.

WARNING: DO NOT USE THE FILTER PUMP TO REMOVE WATER FROM THE VATS AS THIS WILL CAUSE PREMATURE PUMP FAILURE AND VOID THE PUMP WARRANTY.

- 8) Use a scrubbing pad to remove carbon buildup from the top of the heat mechanism. To remove carbon buildup on the sides and bottom of the heat mechanism; slide one end of a stropping pad under each section, grasp that end with a pair of tongs, and rock the pad up and down along the length of each section until all encrusted material has been removed.
- 9) Rinse each fryer with hot water until the water coming out of the drain valve is clear.
- 10) Mix a solution of **ONE PART** vinegar to **25 PARTS** of water. Place this mixture into a one gallon garden pressure sprayer; and **THOROUGHLY** spray this solution onto the **SIDES, HEAT MECHANISM, and BOTTOM** of each fryer to neutralize the Boil-Out Compound.

NOTE: Boil-Out Compound will cause shortening to break down rapidly if it is not neutralized.

- 11) **THOROUGHLY** wipe the sides, heat mechanism, and bottom of each fryer with clean, lint-free, dry towels to remove any remaining water; then fill each fryer with **NEW** shortening following procedures on page 5 of this manual.

**SERVICE
AND
PARTS**

1. **TECHNICAL ASSISTANCE** - Contact an authorized service agent or the Customer Service Department, Ultrafryer Systems at 1-800-525-8130 for technical assistance.

2. **ORDERING INFORMATION:**

A. **REPLACEMENT PARTS** - Provide the following information when ordering replacement parts by phone, fax or mail:

Your company name and phone number
Your company purchase order number
Bill-to address
Ship-to address
Quantity desired
Part number and description of the desired-item
Your name or signature of authorized-buyer
Phone in order to: 1-800-545-9189 Ext 5029
FAX order to: 1-210-731-5099
Mail order to: Ultrafryer Systems
Order Entry Office
P.O. Box 5369
San Antonio, TX 78201
E-Mail your order to: Ultrafryerservice@afce.com

B. **TERMS** - Net 30 days for customers on open accounts. Past due balances will be charged 1 1/2% per month (I 8% per annum) until full balance is paid.

C. **DAMAGES** - Ultrafryer Systems is not responsible for damage occurring in transit. All deliveries must be inspected for damage to shipping containers prior to departure of the delivering carrier. Any damage must be notated on the receiving document to facilitate filing of freight claims. Carriers must be notified immediately and freight inspections must be requested from the carrier. Ultrafryer Systems can and will gladly assist you in preparing and processing of the necessary claims only if proper notification has been accomplished on the carrier delivery document. Damaged equipment and or containers must be available for the claims inspector to inspect.

D. **RETURNS** - Ultrafryer Systems cannot guarantee credit for items returned without proper authorization. All returns must have prior Ultrafryer Systems Customer Service or Warranty department approval. An assigned number will be issued by the approval authority. Please print the assigned number on all returned packages and corresponding paperwork. Returned goods are subject to a 15% restocking charge. Ultrafryer Systems is not responsible for freight charges on returned goods unless authorized by Customer Service and or Warranty personnel. Ultrafryer Systems does not receive freight collect or C.O.D. shipments.

3. **PARTS IDENTIFICATION** - Locate the part on the following sketches and note the index number i.e, 4, 7, etc; then obtain the part number and description for that index number on the right side of the page facing the sketch. Use that part number when ordering a replacement part.

**MODEL PAR-2-20F CE GAS FRYER
FRONT VIEW**

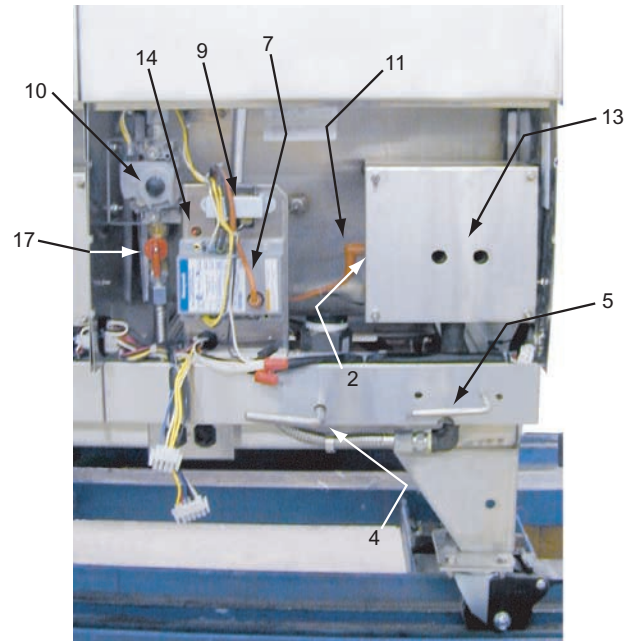

<u>ITEM</u>	<u>DESCRIPTION</u>	<u>PN</u>
* 1	Drain Clean-out Rod.	12-569
2	Ignitor Spark Rod Assembly. NOTE: Set Rod Gap to 5/32" (4mm) prior to installation.	12A043
* 3	20" (508mm) Vat w/Deflector Grill.	12A071
4	2" (51mm) Drain Valve Lever.	12A477
5	1/2" (13 mm) Filter Valve Lever.	19A618
7	24 Volt 50 Hz Spark Ignitor Module.	18A062
8	Drain and Filter Valve Lever Microswitch.	18A064
9	240 Volt to 24 Volt Step-Down Transformer.	18A066
10	Electric Gas Combination Control Valve.	18A067
11	Ignitor Rod Cable w/plugs.	18A068
12	Cast Iron Burner.	19-559
13	Par-2-18&20 Fire Box Assembly w/Interior Gaskets and Ignitor Spark Rod Assembly. Order Weldment Shield PN 22A168, Weldment Shield Gasket Kit PN 12A161 and Firebox cover PN 19-626 when ordering this item.	19A074
14	Hi-Limit Switch Pre-Set to trip at 400° F (204°C). (Order a 1/4" (5mm) Compression Fitting PN 24-247 when ordering this item.)	19A144
*15	Vat Joiner Strip	19A508
*16	Basket Hanger Bracket for all Par-2-20 Fryers.	19A951
17	1/2" (13mm) ID Manual Gas Valve w/Red Handle.	24-326
*18	TO DETERMINE THE NATURAL GAS ORIFICE PLUG DRILL SIZE CHECK THE EUROPEAN PRESSURES, GASES AND SPECIFICATION CATEGORIES TABLE ON PAGE 4.	
*19	1/2" (13mm) MPT x 1/2" (13mm) MPT Flexible Gas Line 36" (914mm) Long.	24A011
*20	Orifice Plug Holder	24A105
*22	Medium Duty 4" (102mm) Front Caster w/Brake.	28-015
*23	"L" Shaped Tip cleaning Brush.	29A044

* **Not Shown**

NOTE: To determine Butane and Propane Gas Orifice Plug Drill Sizes, Check the European Pressures, Gases and Specification Categories Table on Page 4.

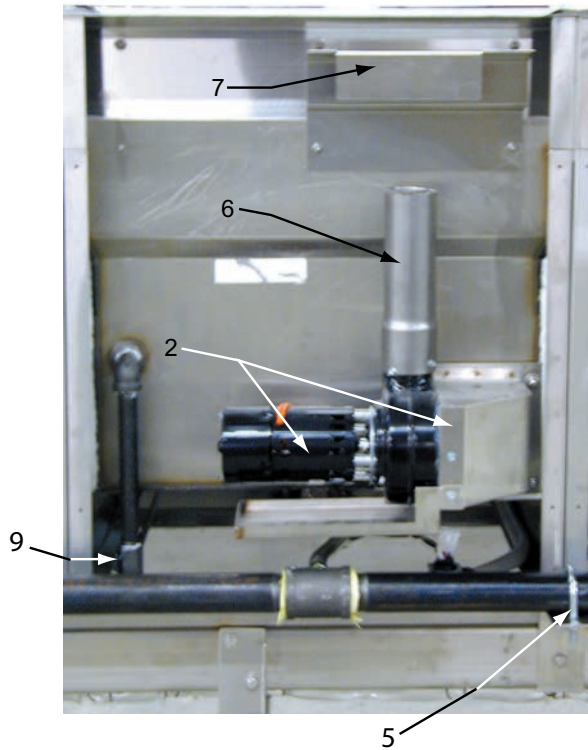

**REAR VIEW
PAR-2-20F CE GAS FRYER**

ITEM	DESCRIPTION	PN
* 1	2" (51mm) Drain Ball Valve Assembly. (Order Gasket 22A119 when ordering this item.)	12-775
2	230 Volt 50 HZ Exhaust Blower Motor	60A004
3	240 Volt Surge Protector	18A063
* 4	Model SMD 1204 Air Pressure Switch.	18A291
5	Gas Manifold Mounting Bracket	19A214
6	2½" Dia x 7⅞" High (54 x 200mm) Flue Tube.	19A459
7	Flue Tube Deflector	19A917
* 8	240 Volt 75 Watt Silicon Heater 5' (1524mm) Long.	23-401
9	Gemini ½" (13mm) Pump Ball Valve	24-036
*10	230 Volt 50 HZ Model GPV-0519 7.7 GPM (29.26 LPM) Viking Pump/Motor. NOTE: For replacement Pump Only order 24-329.	24A036
*11	⅜" (5mm) ID, ⅝" (8mm) OD Air Pressure Switch w/Plastic Tube rated for 500° F (260°C).	24A068
*12	Medium Duty 4" (102mm) Rear Caster w/out Brake.	28-016

Model Par-2 Front Drain Replacement Vats:

VAT SIZE	VAT DEPTH	PN
20" (508 mm)	Standard 10⅞" (276 mm)	12A658

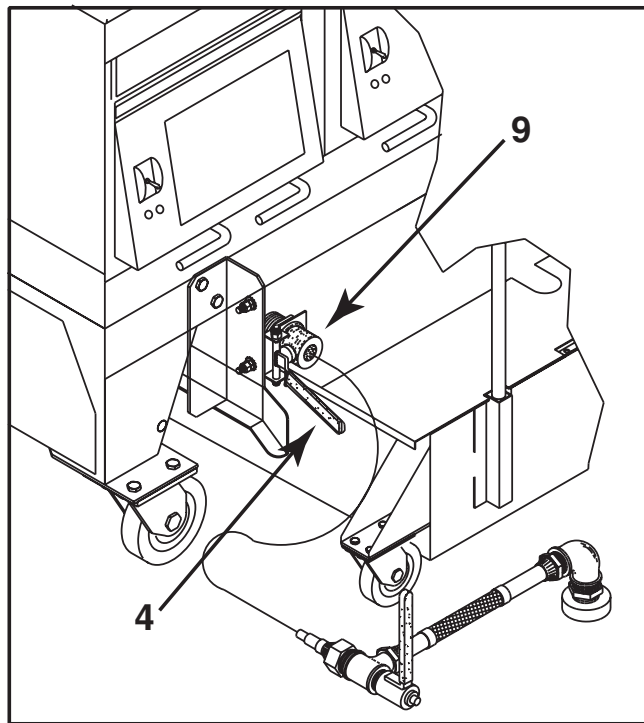

BULKHEAD SUCTION COUPLING

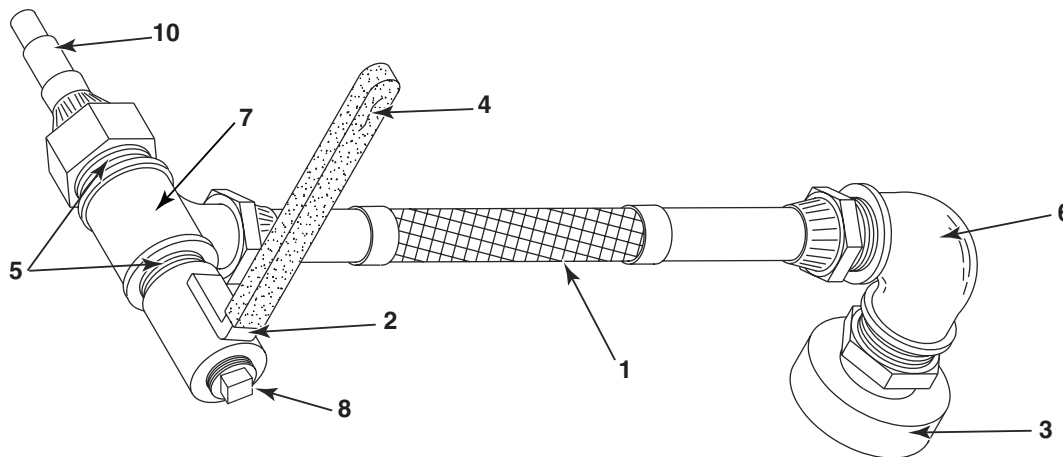

**SUCTION HOSE ASSEMBLY
PN 12A912**

ITEM	DESCRIPTION	PN
1	NSF APPROVED ½" (13 mm) x 10½" (267 mm) Long, Food Grade wire reinforced Hose w/Fittings	12A276
2	Suction Line Hose Handle Assembly	19A932
3	Female Quick-Connect Fitting	22-677
4	Cool Handle II Grip	22-734
5	½" (13 mm) Closed Black Iron Nipple	24-003
6	⅜" (10 mm) x 90° w/½" (13 mm) NPT Internal Threads Black Iron Street Elbow	24-376
7	½" x ½" x ½" (13 x 13 x 13 mm) Black Iron Tee	24A083
8	½" (13 mm) Black Iron Square Head Plug	24A084
9	½" (13 mm) FPT S/S Female Bulkhead Coupling w/raised Push Button Release	24A157
10	½" (13 mm) FPT x 2⅞" (73 mm) Long S/S In-Line Male Plug	24A160

PAR-2-20F CE TEMPERATURE CONTROL ACCESS PANELS

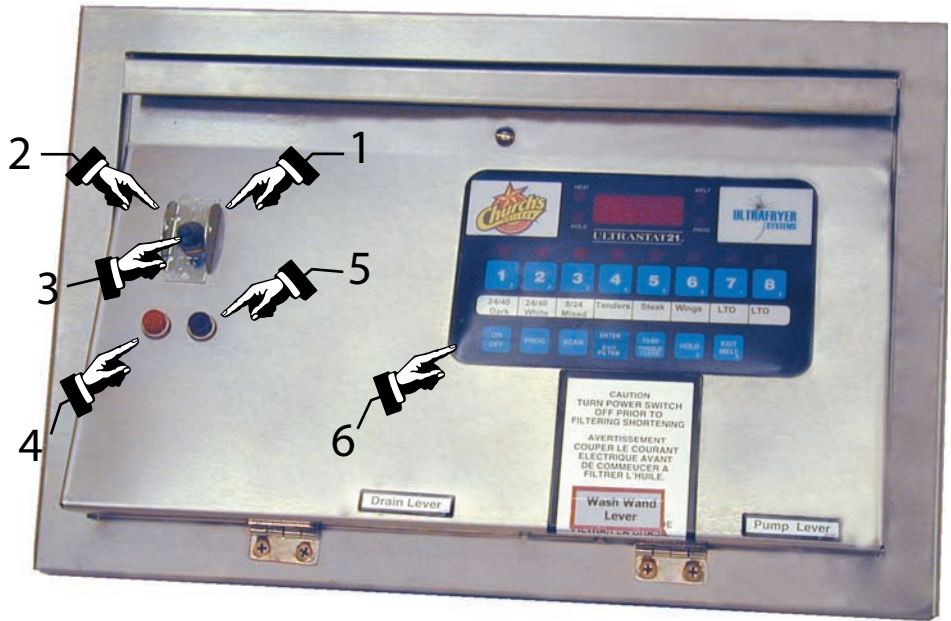

**PAR-2-20F CE
PANEL WITH DIGITAL TIMER**

ITEM	DESCRIPTION	PN
1	On/Off Toggle Switch Guard	18-129
2	6 Amp SPDT Toggle ON/OFF Switch	18A287
3	Toggle ON/OFF Switch Protective Boot	23-402
4	24 Volt 1/3 Watt Snaplight w/ AMBER Lens	23A101
5	24 Volt 1/3 Watt Snaplight w/ RED Lens	23A103
6	Ultrastat 21 Cooking Computer (Uses Temperature Probe 18A006)	NOTE

NOTE: To obtain a replacement “PROGRAMMED” Ultrastat Cooking Computer contact the Customer Service Department at **1-800-525-8130** and provide the following information:

TYPE STORE: CHURCHS, POPEYES COMPANY, POPEYES FRANCHISE, ETC.
TYPE FRYER: ELECTRIC OR GAS
PRODUCT: CHICKEN, FRENCH FRIES, ETC.

PAR-2-20F CE GAS FRYER FILTER TUB ASSEMBLY

**PAR-2-20F CE "UNIVERSAL"
FILTER TUB ASSEMBLY
PN 11A783**

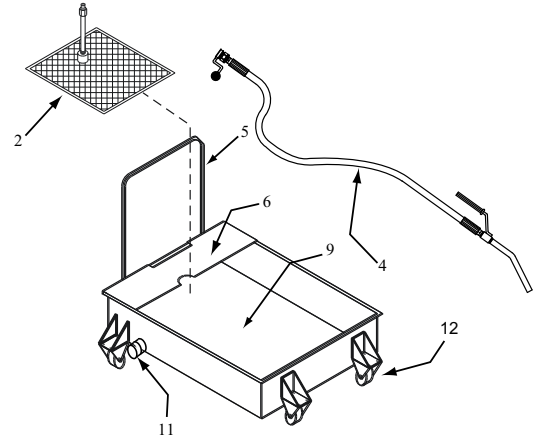

ITEM	DESCRIPTION	PN
* 1	Filter tub Scraper	12-567
2	PAR-2-20F CE Wash Down Hose Assembly	12-330
3	Micro-Mesh S/S Filter Assembly (Note 1)	12A807
4	Filter Tub Handle	19-423
5	Filter Tub Cover	19A481
6	Universal Filter Tub	19A801
* 7	1¼ " (32 mm) Boil-out Drain Ball Valve (Optional)	24A069
8	1¼ " (32 mm) Black Iron Pipe Cap	24A152
9	Medium Duty Caster	28A005

* Item not shown

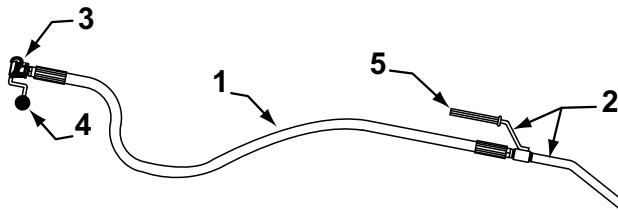

**PAR-2-20F CE
WASH DOWN HOSE ASSEMBLY
PN 12-330**

ITEM	DESCRIPTION	PN
1	6 ft (1829mm) Wash Down Hose w/Fittings	12-541
2	PAR-2-20F CE Wash Down Handle & Nozzle	12-675
3	Hose Quick Disconnect Assembly	19-248
4	Black Ball Knob	22-620
5	Cool II Handle	22-734

**MICRO MESH FILTER SCREEN ASSEMBLY
PN 12A807**

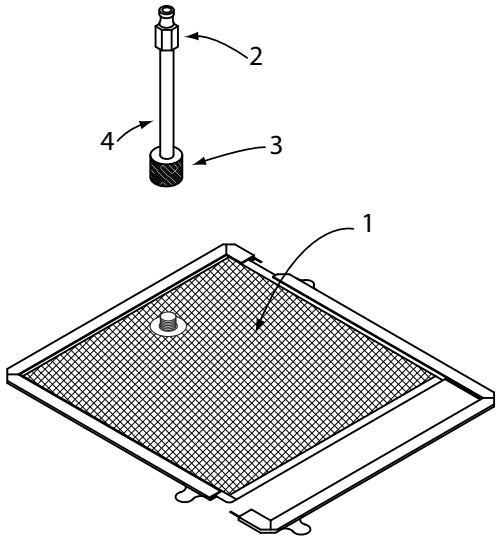

<u>ITEM</u>	<u>DESCRIPTION</u>	<u>PN</u>
1	Micro Mesh Filter Screen (see exploded view)	21A279
2	3/8" (10 mm) NPT Male Stem Quick-Connect Fitting	22-676
3	Top Compression Cap (Knurl Knob)	24-369
4	3/8" (10 mm) x 7" (178 mm) S/S Nipple	24-471

**EXPLODED
VIEW**

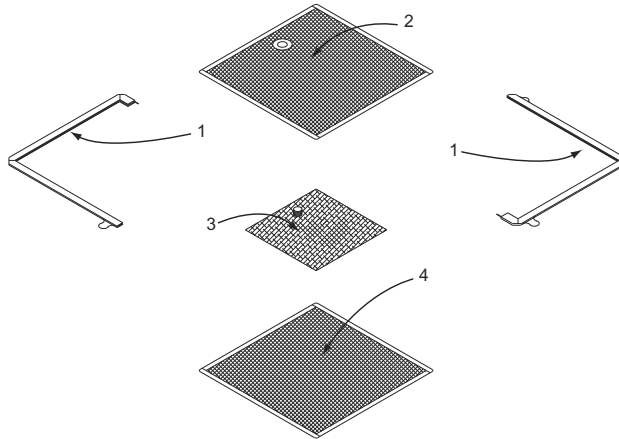

<u>ITEM</u>	<u>DESCRIPTION</u>	<u>PN</u>
1	Filter Screen Frame Set	22A280
2	Upper Filter Screen	21A281
3	Baffle w/suction line fitting	21A282
4	Lower Filter Screen	21A274

WIRING DIAGRAM - Since minor wiring changes may occur in the future, USE the diagram pasted to the Fryer for circuit and / or trouble-shooting a fryer.

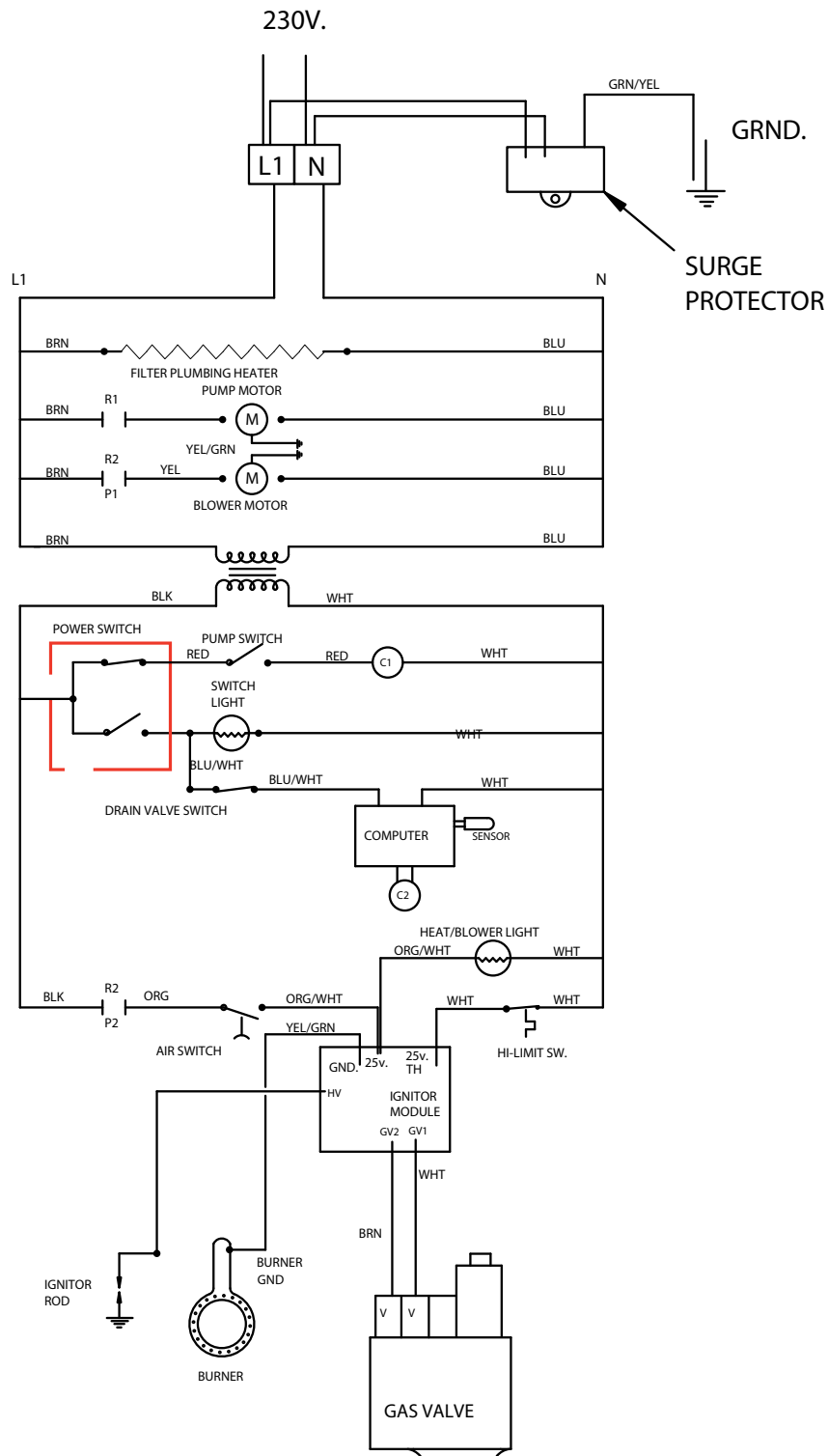

**PAR-2-20F CE GAS FRYER W/COMPUTER
WIRING DIAGRAM**