



UltraPro™ 14

Model F-IRC-14

Operation Instructions



<p>FOR YOUR SAFETY</p> <p>Do not store or use gasoline or other flammable vapors or liquids in the vicinity of this or any other appliance. Fryer for indoor use only.</p> <p>Purchaser to post in a prominent location instructions to be followed in the event the user smell gas.</p> <p>This information shall be obtained by consulting the local gas supplier.</p>	<p>WARNING</p> <p>Improper installation, adjustment, alteration, service, or maintenance can cause property damage, injury or death. Read the installation, operating, and maintenance instructions thoroughly before installing or servicing this equipment.</p>
---	--

302 Spencer Lane • P.O. Box 5369, San Antonio, Texas 78201
 (800) 525-8130 • (210) 731-5000 • Fax: (210) 731-5099
www.ultrafryer.com

PREFACE

This manual was written and published by the Ultrafryer Systems Engineering Department for use by personnel who will operate a Model F-IRC-14 Premix Gas Fryer in a commercial cooking environment. Proper use of a manual will allow store employees to operate, clean, and maintain equipment properly, thereby reducing service call expenses.

This appliance is intended for professional use and is to be operated by qualified personnel.

This manual is to be retained for future reference.

Throughout this manual, **NOTES**, **CAUTIONS**, **WARNINGS** and **DANGERS** are used to alert the operator to items of special circumstances.

These items are identified as follows:

NOTE:

Test Start-Up. Operation, Cooking Filtering and Boil-Out Procedures of a 14" Model IRC Premix Gas Fryer in the manual are based on the Ultrastat® 402 Cooking Computer.
Refer to Manual P/N 30A290 to perform these functions in a fryer equipped with this controller.

CAUTION:



TO ASSURE PRODUCING A QUALITY PRODUCT WHILE PROLONGING THE LIFE EXPECTANCY OF THE FRYER, ENSURE THAT THE BOIL-OUT AND CLEANING INSTRUCTIONS ARE STRICTLY FOLLOWED.

WARNING:



DO NOT ALLOW ANY CLEANING SOLUTION OR WATER TO SPLASH INTO A VESSEL OF HOT COOKING OIL, AS IT WILL CONTAMINATE THE OIL AND MAY CAUSE THE OIL TO SPLATTER CAUSING SEVERE BURNS.

DANGER:



THE FRYER MUST BE CONNECTED ONLY TO THE TYPE OF GAS IDENTIFIED ON THE RATING PLATE !

NOTE:

This manual is intended as a guide for all Model F-IRC-14" Premix Gas Fryers, regardless of configuration and controllers. It is to be used in conjunction with the applicable controller manual that is included with the fryer.

TABLE OF CONTENTS

1. GENERAL INFORMATION	5
1.1. DESCRIPTION	5
1.2. SAFETY	5
1.3. AUTOMATIC SAFETY FEATURES	5
1.4. SPECIFICATIONS.....	6
1.5. RATING PLATE	6
1.6. INLET GAS LINE SIZING	7
1.7. FLEXIBLE GAS LINE LENGTHS.....	8
2. PRE-INSTALLATION	8
2.1. GENERAL.....	8
2.2. STANDARDS	9
2.3. AIR SUPPLY AND VENTILATION	9
3. RECEIVING AND INSTALLING.....	10
3.1. UNPACKING	10
3.2. INSTALLING	10
3.3. LEVELING	10
3.4. GAS CONNECTION.....	11
3.5. ELECTRICAL CONNECTION	13
4. ULTRASTAT® 402 COOKING COMPUTER	14
4.1. ULTRASTAT® 402 COOKING COMPUTER	14
4.2. GENERAL COOKING.....	15
4.3. STARTING A COOK CYCLE	16
4.4. CANCELLING A COOK CYCLE.....	17
5. SHORTENING FILTRATION PROCEDURE	18
5.1. SHORTENING FILTRATION PROCEDURE	18
5.2. WASH WAND OPERATION	21
6. CLEANING	23
6.1. GENERAL CLEANING	23
7. PREVENTIVE MAINTENANCE AND TROUBLESHOOTING	23
7.1. PREVENTIVE MAINTENANCE.....	23
7.2. TROUBLESHOOTING	24
8. TECHNICAL ASSISTANCE, WARRANTY PARTS & REPLACEMENT PARTS ASSISTANCE	27
8.1. TECHNICAL ASSISTANCE	27
8.2. WARRANTY PARTS	27
8.3. REPLACEMENT PARTS.....	27
9. RECOMMENDED SPARE PARTS	27
9.1. RECOMMENDED SPARE PARTS	27
10. PARTS IDENTIFICATION.....	28
10.1. F-IRC-14 - CONTROL PANEL.....	28
.....	28
10.2. CABINET FRONT VIEW	29

10.3.	CABINET REAR VIEW	30
10.4.	CABINET REAR VIEW	31
11.	SERVICE PROCEDURES AND ADJUSTMENTS	32
11.1.	HARMONIC TONE.....	32
11.2.	GAS VALVE	32
11.3.	MODULATING GAS VALVE ADJUSTMENTS.....	32
11.4.	TEMPERATURE PROBE SETTING.....	34
	34
11.5.	HI LIMIT PROBE SETTING.....	34
11.6.	INFRARED BURNER SPARK IGNITOR AND FLAME SENSOR SETTING	35
11.7.	GROUND ROD GROUND WIRE CONNECTION	35
11.8.	CONTROL, 24 VAC UNIVERSAL GAS BLOWER (PWM) SETTINGS.....	36
	36
	36
	36
	36
	36
	36
12.	LADDER DIAGRAM	37
12.1	. LADDER DIAGRAM	37
12.2	. SCHEMATIC	38
	38

1. GENERAL INFORMATION

1.1. DESCRIPTION

The Ultrafryer® 14~~4~~ IRC premix gas fryer was designed by Ultrafryer Systems® to operate as an energy-efficient, gas-fryer and is design-certified by the Canadian Standards Association (CSA) and the National Sanitation Foundation (NSF). It is manufactured to operate on either NATURAL or PROPANE gas according to the following Operational Requirements. Each fryer is shipped completely assembled with the accessories packed inside the fryer vat and each fryer has been adjusted, tested and inspected prior to shipment. This gas fryer is designed to be used in a commercial food preparation environment after it is properly installed as outlined in this manual.

1.2. SAFETY

The major safety concern associated with the Ultrafryer® Infrared Premix Gas fryer is burns from hot shortening. In order to prevent serious burns, good housekeeping habits are required. The floor in front of and the area around the fryer should be kept clean and dry. Whenever anything is placed into a fryer vat, care should be used not to splash the hot shortening. Product should always be “PLACED” into the shortening, NOT THROWN. Safety goggles, neoprene insulated gloves, and an apron must be worn while boiling-out a fryer vat.

Electrical controls used in the gas fryer operate on 120 volts single phase electrical power, and no adjustments or replacement of electrical controls should ever be attempted without first disconnecting electrical power. The fryer should never be operated with wet hands or while standing in water. To do so can result in serious electrical shock or death.

1.3. AUTOMATIC SAFETY FEATURES

This fryer is equipped with the following Automatic Safety Features:

1. High Limit thermostat to shut off gas to the main burners by operating a solenoid-activated safety valve in the combination gas control valve if shortening temperature exceeds 400°F (204°C).
2. Combination gas control valve which includes a built-in pressure regulator.
3. Air pressure switch to open the 24volt electrical circuit to the gas control valve, which turns gas to the fryer OFF if a blower motor becomes inoperable.
4. Sensing Circuit within the spark ignitor module to turn gas OFF if a burner FLAME OUT occurs.
5. A current sensor and air pressure switch, combined provide an air proof system for the fryer.
6. A drain valve safety switch and a default to OFF circuit that will disable the fryer each time the drain valve is opened.

1.4 SPECIFICATIONS

MODEL F-IRC-14 (355mm) PREMIX GAS FRYER OPERATIONAL REQUIREMENTS.

SPECIFICATION ITEM	IRC - 14"
Overall Width	15.35" (389mm) Each vat
Overall Depth	36.31" (922mm)
Work Height	36.12" (918mm)
Oil Capacity High Level	45 lbs. (24.94 liters) 35 lbs. (22 liters)
Vat Container Size	14.00"x14.00" (356mmx356mm)
Gas Pressure (inlet to fryer)	
Natural Gas	7" (178mm) W.C.
Propane	11" (280mm) W.C.
Gas Rating	
Natural Gas	90K BTU/hr (94.95MJ/HR)
Propane	90K BTU/hr (94.95MJ/HR)
Power Input	120 Volt, 1.2 Amps, each vat + 3.1 Amps with pump motor, 60Hz, 1 Phase

FT³/HR (M³/HR) VALUES May vary due to heating value and specific gravity of gas supplied by local Gas Company.

NOTE:

Test should be a Start-up, Operation, Cooking, Filtering and Boil-Out Procedures of a Model IRC-14" Premix Gas Fryer in the manual are based on the Ultrastat® 402 Cooking Computer. Refer to Manual P/N 30A286 to perform the functions in a fryer equipped with this controller.

1.5. RATING PLATE

The rating plate is located on the inside of the Service Access door and contains the following information: the model and serial numbers, BTU/HR input rating of the burners, gas manifold pressure in inches W.C., minimum inlet gas required and gas type. This data is essential for proper identification when communicating with ULTRAFRYER SYSTEMS or requesting special parts or information.

DANGER:



THE FRYER MUST BE CONNECTED ONLY TO THE TYPE OF GAS IDENTIFIED ON THE RATING PLATE!

1.6. INLET GAS LINE SIZING

INLET GAS LINE SIZING - The Table below is to be utilized to calculate the size (diameter) of the inlet gas line from the building regulator to the fryer manifold.

INLET GAS LINE REQUIREMENTS									
PIPE LENGTH	PIPE DIAMETERS (inches & mm equivalents)								
	Maximum Allowable Flow (Shown in ft ³ /hr & M ³ /hr)								
Feet (Meters)	½" (13mm)	¾" (19mm)	1" (25mm)	1¼" (32mm)	1½" (38mm)	2" (51mm)	2½" (64mm)	3" (76mm)	4" (102mm)
15 (4.6)	62 (1.7)	108 (4.7)	350 (9.8)	620 (17.4)	960 (26.9)	2,000 (56.0)	3,500 (98.0)	5,400 (151.2)	11,200 (313.6)
30 (9.1)	43 (1.2)	120 (3.4)	245 (6.9)	430 (12.0)	680 (19.0)	1,400 (39.2)	2,450 (68.6)	3,800 (106.4)	7,900 (221.2)
45 (13.7)	35 (1.0)	98 (2.7)	200 (5.6)	355 (9.9)	530 (14.8)	1,150 (32.2)	2,000 (56.0)	3,200 (89.6)	7,900 (182.0)
60 (18.3)	30 (0.8)	84 (2.4)	175 (4.9)	310 (8.7)	480 (13.4)	1,000 (28.0)	1,760 (49.3)	2,700 (75.6)	5,600 (156.8)
75 (22.9)	27 (0.8)	76 (2.1)	155 (4.3)	275 (7.7)	430 (12.0)	890 (24.9)	1,560 (43.7)	2,450 (68.6)	5,000 (140.0)
90 (27.4)	25 (0.7)	70 (2.0)	145 (4.1)	250 (7.0)	395 (11.1)	810 (22.7)	1,430 (40.0)	2,260 (63.3)	4,550 (127.4)
105 (32.0)	23 (0.6)	64 (1.8)	132 (3.7)	232 (6.5)	370 (10.4)	750 (21.0)	1,300 (36.4)	2,100 (58.8)	4,200 (117.6)
120 (36.6)	21 (0.6)	60 (1.7)	125 (3.5)	215 (6.0)	340 (9.5)	700 (19.6)	1,200 (33.6)	1,950 (54.6)	4,000 (112.0)
150 (45.7)	19 (0.5)	54 (1.5)	110 (3.1)	195 (5.5)	310 (8.7)	630 (17.6)	1,080 (30.2)	1,750 (49.0)	3,550 (99.4)
180 (54.9)	17 (0.5)	49 (1.4)	100 (2.8)	175 (4.9)	280 (7.8)	570 (16.0)	960 (26.9)	1,600 (44.8)	3,200 (89.6)
210 (64.0)	16 (0.4)	44 (1.2)	94 (2.6)	165 (4.6)	260 (7.3)	530 (14.8)	890 (24.9)	1,450 (40.6)	3,000 (84.0)
240 (73.2)	15 (0.4)	43 (1.2)	88 (2.5)	155 (4.3)	240 (6.7)	500 (14.0)	840 (23.5)	1,350 (37.8)	2,800 (78.4)
270 (82.3)	14 (0.4)	40 (1.1)	83 (2.3)	145 (4.1)	230 (6.4)	470 (13.2)	780 (21.8)	1,300 (36.4)	2,650 (74.2)
300 (91.4)	14 (0.4)	38 (1.1)	79 (2.2)	138 (3.9)	215 (6.0)	440 (12.3)	750 (21.0)	1,250 (35.0)	2,500 (70.0)
450 (137.2)	11 (0.3)	31 (0.9)	64 (1.8)	112 (3.1)	176 (4.9)	360 (10.1)	630 (17.6)	1,000 (28.0)	2,050 (57.4)
600 (182.9)	10 (0.3)	27 (0.8)	56 (1.6)	97 (2.7)	152 (4.3)	315 (8.8)	530 (14.8)	860 (24.1)	1,750 (49.0)

NOTE:

1. FT³/HR (M³/HR) values may vary due to heating value and specific gravity of gas supplied by local companies.
2. To determine the inlet gas line diameter for the distance between the fryer and main gas regulator, locate the FT³/HR (M³/HR) of gas required for the fryer and pipe length and read the pipe diameter on the top row. For example: a bank of fryers containing three (3) Par-3-14 fryer operating on Natural gas requires 257.13 FT³/HR (7.29 M³/HR) <3x85.71 (2.43)>. If the fryer bank is located 60 feet from the building gas regulator, a 1¼" (32mm) diameter gas line MUST be installed between the fryer gas manifold and the building gas regulator.

1.7. FLEXIBLE GAS LINE LENGTHS

The Flexible Gas Line used to connect the gas manifold to the building gas supply line must be rated for the BTU/Hr (MJ/Hr) designated for the Fryer. Flexible gas lines and their ratings stocked by Ultrafryer Systems are listed below:

FLEXIBLE GAS LINES STOCKED BY ULTRAFRYER SYSTEMS			
NUMBER	DESCRIPTION	RATING	
		BTU/HR	(MJ/HR)
24322	¾" (19mm) Diameter Flexible Gas Line (w/quick connect couplings) 48" (1219mm) long. Connect-It SSGC75-48-UCQ	225,000	(238)
24323	1" (25mm) Diameter Flexible Gas Line (w/quick connect couplings) 48" (1219mm) long. Connect-It SSGC100-48-UCQ	435,000	(459)
24456	1 ¼" (32mm) Diameter Flexible Gas Line (w/quick connect couplings) 48" (1219mm) long. Connect-It SSGC125-48-UCQ	875,000	(924)

2. PRE-INSTALLATION

2.1. GENERAL

Safe and satisfactory operation of a Model F-IRC-14 premix gas fryer depends on its proper installation. Installation must conform to local codes or, in the absence of local codes, with the current National Fuel Gas Code ANSI Z223.1/NFPA 54 or (latest edition). In Canada, gas installation shall be in accordance with the current CSA B 149.1 and .2 installation codes and/or local codes. Each Model F-IRC-14" premix gas fryer should be installed as follows:

1. Placed beneath a properly designed exhaust hood.
2. Installed by a licensed electrician and plumber.
3. Connected to the type gas for which the unit was fabricated as shown on the rating plate.
4. Connected to the proper size pressure regulator installed in the gas supply line and adjusted to the proper manifold pressure.
5. Connected to the main gas supply line with the proper size supply line.
6. Restrained by use of a restraining device to avoid splashing of hot liquid and to assure tension cannot be placed on the flexible gas or electrical lines or fittings. CLEARANCES: The appliance must be kept free and clear of all combustibles. The minimum clearance from combustible and non-combustible construction is 6" (152 mm) from the sides, and 6" (152 mm) from rear. The fryer may be installed on combustible floors.

NOTE:

Adequate clearance must be provided for servicing and proper operation.

2.2. STANDARDS

Installation must be planned in accordance with all applicable state and local codes, considering the following standards:

1. The fryer and its individual shut-off valve must be disconnected from the gas supply piping system during any pressure testing of that system at pressures in excess of 1/2 psig (3.45kPa). In Canada, gas installation shall be in accordance with the current CSA B 149.1 and .2 installation codes and/or local codes.
2. The fryer must be isolated from the gas supply piping system by closing its individual manual shut-off valve during any pressure testing of the gas supply piping system at pressures equal to or less than 1/2 psig (3.45kPa).
3. When installed the fryer must be electrically grounded in accordance with local codes, or in the absence of local codes, in accordance with the current National Electrical code ANSI/NFPA 70 or latest edition. In Canada electrical installation must be in accordance with the current CSA C22.1 Canadian Electrical Code and/or local codes.
4. Other applicable nationally recognized installation standards such as:
 - a. National Fuel Gas Code ANSI Z223.1/NFPA 54 or latest edition
American Gas Association.
 - b. NFPA Standards #54, #94 and #221 latest edition
National Fire Protection Association.
 - c. ANSI Z21.69/CSA-6.16 AND ANSI Z21.41/CSA 6.9
5. Exhaust vent hood, when installed must conform to the current NFPA 54-1 and Canadian Standards or latest edition.

NOTE:

Local building codes will usually not permit a fryer with its open tank of hot oil to be installed immediately next to an open flame of any type, whether a broiler or an open burner or range. Check local codes before beginning installation.

2.3. AIR SUPPLY AND VENTILATION

The area around the appliance must be kept clear of any combustible or flammable products and avoid any obstruction to the flow of ventilation air as well as for ease of maintenance and service. NOTHING is to be stored in the interior of the fryer's cabinet.

1. A means must be provided for any commercial, heavy duty-cooking appliance to exhaust combustion wastes outside of the building. It is essential that a fryer be set under a powered exhaust vent hood or that an exhaust fan be provided in the wall above the unit, as exhaust temperatures are in the vicinity of 700°F (371°C).

NOTE:

Strong exhaust fans in a hood or in the overall air conditioning system can produce slight air drafts in the room, which can interfere with burner performance and be hard to diagnose. Air movement should be checked during installation and if burner problems persist, make-up air openings or baffles may have to be provided in the room.

2. Exhaust temperature, in addition to the open tank of hot oil, make the storage of anything on shelving over or behind the fryer unsafe.
3. Filters and drip troughs should be part of any industrial hood, but consult local codes before constructing and installing any hood.

3. RECEIVING AND INSTALLING

3.1. UNPACKING

Check that the container is upright. Use an outward prying motion – DO NOT USE A HAMMER - to remove the carton. Check the fryer for visible damage; if such damage has occurred do not refuse shipment, but contact the carrier and file the appropriate freight claims.

3.2. INSTALLING

Roll the assembled fryer into the building, to its operating location.



IMPROPER INSTALLATION, ADJUSTMENT, ALTERATION, SERVICE, OR MAINTENANCE CAN CAUSE PROPERTY DAMAGE, INJURY, OR DEATH. READ THE INSTALLATION, OPERATING AND MAINTENANCE INSTRUCTIONS THOROUGHLY BEFORE INSTALLING OR SERVICING THIS EQUIPMENT.

3.3. LEVELING

1. When the fryer is placed in its operating location, check to be sure it is level. If not, loosen the casters and insert the appropriate number of shim plates between leg and caster plates then retighten the caster bolts.
2. If the floor is smooth and level, adjust to the high corner and measure with a spirit level. If the floor is uneven or has a decided slope, level the unit with metal shims.

NOTE:

A Caster may not return exactly to the same position after being moved, which may require re-leveling after each move.

3. Connect the gas manifold to the building gas supply line by means of a CSA Group APPROVED flexible gas line as shown in the figure below.

NOTE:

CONNECT-IT Inc. ¾" (19mm), 1" (25mm) and 1 ¼" (32mm) flexible gas hose 4 feet long (1219mm) with a quick disconnect coupling on one end is available from Ultrafryer Systems under PN 24322 (¾" (19mm) hose), PN 24323 (1" (25mm) hose) and PN 24456 (1 ¼" (32mm) hose). These hoses are equipped with a fusible link, which melts at 316 °F (183 °C) that will SHUT OFF the gas supply when it melts. Reference Installation Instructions sheet provided with hose for additional information. A 44" (1119mm) long restraining device is also available under PN 24324. Install as Shown below between the wall and fryer using existing mounted hardware or add hardware to the wall and fryer making a secure connection at each end.

CAUTION:

THE BUILDING GAS SUPPLY LINE MUST BE SIZED TO PROVIDE THE VOLUME OF GAS REQUIRED FOR PROPER OPERATION AS EXPLAINED ON THE PREVIOUS PAGE.

Typical Gas Connection

- | | |
|--------------------------------|------------------------------|
| 1. BUILDING GAS SERVICE LINE | 6. APPLIANCE MANIFOLD/NIPPLE |
| 2. MAIN GAS CUT-OFF VALVE | 7. EYELET FASTENERS |
| 3. CONNECT-IT QUICK-DISCONNECT | 8. SPRING HOOK |
| 4. FLEX-CON CONNECTOR | 9. RESTRAINING CHAIN |
| 5. ELBOW | |

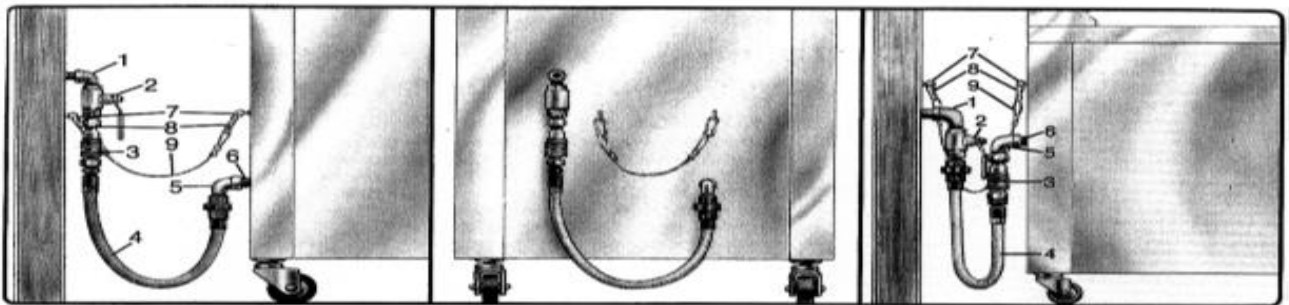
**WARNING:**

THE RESTRAINT DEVICE (ITEM 9) MUST BE INSTALLED TO ASSURE TENSION CANNOT BE PLACED ON THE FLEXIBLE GAS LINE OR FITTING.

3.4. GAS CONNECTION

The gas supply (service) line must be the same size or greater than the inlet line of the appliance.

THE GAS SUPPLY LINES MUST BE SIZED TO ACCOMMODATE ALL THE GAS FIRED EQUIPMENT THAT MAY BE CONNECTED TO THAT SUPPLY.

Refer to the inlet gas line sizing table and inlet gas requirements.

NOTE:

Sealant used on all pipe joints must be resistive to natural and propane gas.

1. Manual shut off valve: This supplier-installed valve must be installed in the gas service line ahead of the appliance and in a position where it can be reached quickly in the event of an emergency.
2. Pressure regulator: All commercial cooking equipment must have a pressure regulator on the incoming service line for safe and efficient operation, because service pressure may fluctuate with local demand. External regulators are not required on this fryer, as that function is

performed by a combination gas control valve, however if the incoming pressure is in excess of 1/2 psi, a step-down regulator will be required.

3. Natural gas: Natural gas fryers require 7" (178mm) water column (W.C.) "inlet" pressure to the fryer's combination gas control valve for proper operation, when all gas units are operating
4. simultaneously. Propane gas fryers require 14" (356mm) water column (W.C.) "inlet" pressure to the fryer's combination gas control valve for proper operation, when all gas units are
5. operating simultaneously. This "inlet" pressure **MUST** be checked with a manometer **PRIOR** to placing the fryer in operation.



IF THE "INLET" GAS PRESSURE AT THE FRYERS COMBINATION GAS CONTROL VALVE "EXCEEDS" 1/2 lb/in² (.035 kg/cm²) OR APPROXIMATELY 11" (280mm) W.C., AN EXTERNAL REGULATOR MAY BE NEEDED TO PREVENT DAMAGE TO THE COMBINATION GAS VALVE, AND VOIDING OF WARRANTY.

6. Combination gas control valve: The correct combination gas control valve and orifice is installed at the factory for **NATURAL** and **PROPANE** units based on each Purchase Order. This valve
7. should be **CHECKED/ADJUSTED** by qualified service personnel using proper test equipment for the following **"OUTLET"** gas pressure **PRIOR** to start-up of a fryer.
 - a. NATURAL GAS FRYERS 7" (178mm) W.C.
 - b. PROPANE FRYERS 14" (355.6mm) W.C.
8. Rigid connections: Visually check any installer-supplied intake pipe(s) with compressed air to clear dirt particles, threading chips or any other foreign matter before connecting to the service
9. line as these particles may clog the orifice when gas pressure is applied. All connections must be tested with a soapy solution before lighting the fryer. **DO NOT USE AN OPEN FLAME TO**
10. **CHECK FOR LEAKS!** Putting an open flame beside a new connection is not only dangerous, but will often miss small leaks that a soapy solution would find.

FLEXIBLE COUPLINGS AND CONNECTORS: The installation is to be made with a connector that:

1. Complies with the **Standard for Connectors for Movable Gas Appliances, ANSI Z21.69/CSA 6.16**, and a quick-disconnect device that complies with the **Standard for Quick-Disconnect Devices for Use With Gas Fuel, ANSI Z21.41/CSA 6.9**
2. Adequate means must be provided to limit the movement of the appliance without depending on the connector and the quick disconnect device or its associated piping to limit the appliance movement.
3. The location(s) where the restraining means may be attached to the appliance shall be specified. Mounting holes for restraining cable is located on the rear legs of the fryer carriage.

WARNING DOMESTIC CONNECTORS ARE NOT SUITABLE!!!

FRYER SERVICE: The fryer is equipped with swivel casters. To service the fryer:

- a) Remove/unplug power supply from fryer.

- b) Turn "OFF" gas supply at the supply source.
- c) Disconnect the flexible gas line quick-disconnect
- d) Disconnect restraint means and roll fryer out for rear service access.
- e) When the fryer is re-positioned, be sure to reconnect the restraint and level the fryer.

3.5. ELECTRICAL CONNECTION

The MAXIMUM current draw per vat at Initial Start-up or during a Warm-up Cycle will be 3 Amperes at 120 Volts. When running the Filter System simultaneously allow for an additional 3 Amperes. Refer to the wiring diagram attached to the inside of the Service Access door for internal electrical connections.

WARNING:



ELECTRICAL GROUNDING INSTRUCTIONS

THIS APPLIANCE IS EQUIPPED WITH A THREE-PRONG (GROUNDING) PLUG FOR YOUR PROTECTION AGAINST SHOCK HAZARD AND SHOULD BE PLUGGED DIRECTLY INTO A PROPERLY GROUNDED THREE-PRONG RECEPTACLE. DO NOT CUT, REMOVE OR OTHERWISE BYPASS THE GROUNDING PRONG ON THIS PLUG!

4. ULTRASTAT 402 COOKING COMPUTER

4.1. ULTRASTAT® 402 COOKING COMPUTER

The Ultrastat 402 Cooking Computer is a high performance, microprocessor-based electronic controller designed for use in commercial appliance temperature and timing control applications. Utilizing a touch screen display front panel, the Ultrastat 402 Cooking Computer has been customized for Ultrafryer Systems applications by the addition of up to 10 stage cooking profiles for each of the 10 product keys; features can be programmed to cook products under “Flex” or “Straight” timing modes. Operation of the Ultrastat 402 Cooking computer is covered in its Instruction Manual PN 30A286 provided with the Fryer.

4.2. GENERAL COOKING

Most products should be cooked with a shortening temperature about 350°F (177°C); however, each product should be cooked at the LOWEST temperature that produces a high quality product while obtaining maximum usage of the shortening.

WARNING: 

- I. USE A HIGH QUALITY SHORTENING TO ACHIEVE A CONSISTENT QUALITY PRODUCT AND LONG TERM SAVINGS.
- II. DO NOT SALT PRODUCTS OVER THE FRYER AS SALT QUICKLY DETERIORATES THE SHORTENING AND FLAVORS OTHER PRODUCTS COOKED IN THE SAME SHORTENING.
- III. FILTER SHORTENING AFTER THE LUNCH AND DINNER RUSH AND MORE OFTEN IN A HIGH SALE VOLUME STORE; AND BOIL-OUT THE FRYER EVERY 7 DAYS.

NOTE:

Startup steps 1, 2, 3 and 4 will have to be repeated each time any of the following occurs:

Drain valve is open, fryer ON/OFF switch is turned OFF to filter shortening or boil-out a fryer. Fryer ON/OFF switch is turned OFF at closing or any other reason.

POWER FAILURE

This fryer cannot be operated during power failures. **DO NOT** attempt to bypass safety devices or measures and manually operate fryer.

CAUTION: 

THE FRYER HAS A RESTRAINT ATTACHED TO THE WALL TO LIMIT MOVEMENT AND TIPPING IN ORDER TO AVOID SPLASHING OF HOT LIQUID.

MOVING THE FRYER WITH HOT COOKING OIL IN THE VESSEL MAY CAUSE SPLASHING OF THE HOT LIQUID CAUSING SEVERE BURNS.

IF MOVING THE FRYER IS REQUIRED FOR CLEANING OR SERVICING. TAKE THE REQUIRED STEPS OF REMOVING THE RESTRAINT, POWER AND GAS CONNECTIONS BEFORE MOVING THE FRYER AND MAKE SURE THE COOKING OIL IN THE VESSEL IS COLD OR HAS BEEN REMOVED FROM THE VESSEL TO LIMIT ACCIDENTAL BURNS OR DAMAGE TO THE FRYER.

When the Computer is taken out of the SHORTENING MELT MODE each morning, shortening in the fryer vat will be heated to its SETPOINT temperature, “HEATING” will appear in the display to indicate the shortening temperature is MORE than 20°F (-6.6°C) BELOW the set point temperature. When shortening temperature rises to the SETPOINT temperature, “READY” will appear in the display indicating a COOK CYCLE can be started.

4.3. STARTING A COOK CYCLE

To start a cook cycle simply press the product key for the product you wish to cook. Cook time will be displayed (“3:00” ex.) and this time will immediately start to count down in minutes and seconds. It will count down to “ :00” followed by a beeping signal. To turn this signal OFF and reset the Computer, press the same product key used to start the COOK CYCLE.

4.4.1 START-UP and COOKING

<u>STEP</u>	<u>ACTION</u>	<u>RESPONSE</u>
1	ENSURE the drain valve lever on the fryer is in the CLOSED position, shortening is at the proper level.	A. To heat the shortening.

4.4.2 ULTRASTAT 402 START-UP - Safely start-up a gas fryer equipped with a Ultrastat 402 Cooking computer as follows:

CAUTION:



PRIOR TO PROCEEDING TO NEXT STEP, VISUALLY CHECK THAT THE HEAT EXCHANGER IS COVERED WITH AT LEAST 2" (51mm) OF SHORTENING.

2	Turn the Computer ON by depressing the computer ON/OFF button.	<p>A. The computer display screen will indicate when the fryer is in SHORTENING MELT MODE.</p> <p>B. The computer display will then say MELT on the fryer which will cycle ON and OFF indicating the heat mechanism is periodically being turned ON and OFF to gently heat the shortening.</p>
3	Once the Melt Limit Temperature is reached depress the OK/EXIT on the computer to cancel the SHORTENING MELT MODE.	<p>A. “HEATING” will appear in the computer display indicating shortening temperature is more than 10°F (5°C) below the set-point temperature.</p> <p>B. The “HEATING” on the display will remain ON until the set-point temperature is reached.</p>
4	When “READY” appears in the Computer display indicates the SET-POINT TEMPERATURE of the shortening has been reached, a COOK cycle can be initiated.	<p>A. Stir the shortening counter clock wise several times to ensure that all the shortening has reached the set point temperature.</p>

4.4.3 ULTRASTAT 402 COOKING COMPUTER PROGRAMMING

Program the Ultrastat® 402 Cooking Computer according to the, Computer Operating Instructions Manual, (PN 30A286) provided with the Fryer.

NOTE:

Programming of an Ultrastat® 402 cooking computer should only be performed by a store manager or area supervisor.

4.4. CANCELLING A COOK CYCLE

If a cook cycle was inadvertently started it may be cancelled two (2) ways:

- 1) Press and hold the same product key used to start the cook cycle for 4 SECONDS. This prevents an accidental start of a cook cycle while a product is being cooked.
- 2) A cook cycle can be CANCELLED at any time by turning the fryer ON/OFF Switch to the OFF position.



5. SHORTENING FILTRATION PROCEDURE

5.1. SHORTENING FILTRATION PROCEDURE

Fryer Filtration with Filter Tub and Suction Line Assembly

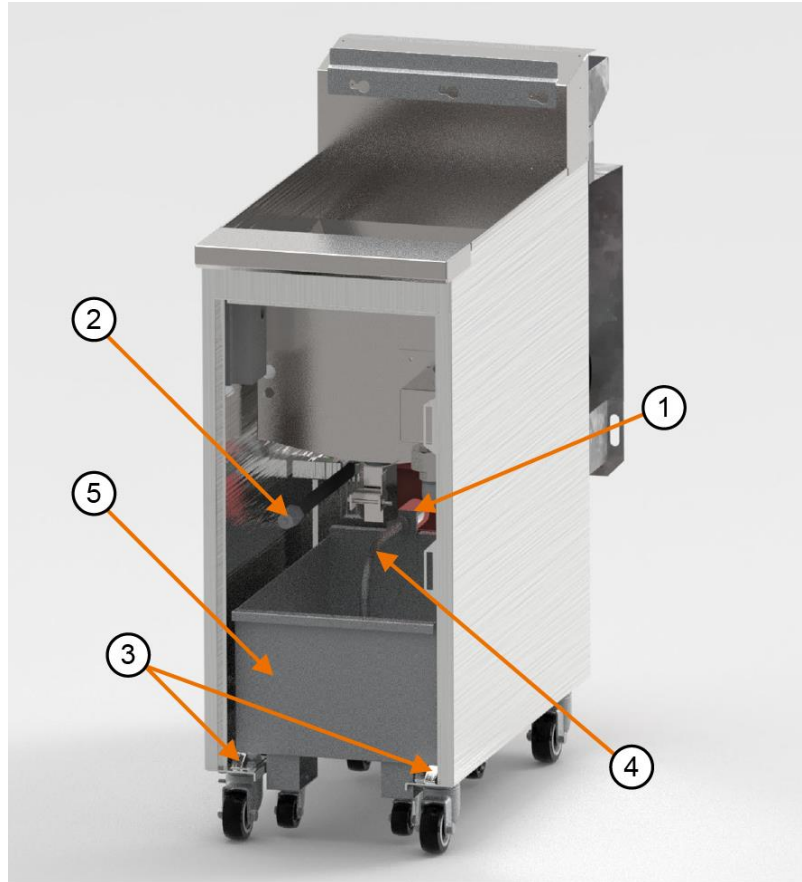

ITEM	DESCRIPTION
1	Suction Line Connection for Filter Pump (on bulkhead)
2	Wash Wand Connection
3	Filter Tub Rail
4	Suction Line Assembly
5	Filter Tub

COOK COMPUTER CONTROL PANEL

1	“ON/Off” Switch
2	Cook Computer (Ultrastat 402 computer Shown)



Effective and safe filtration is accomplished as follows:

1. Turn on the computer on the vat that is to be filtered
2. Turn the “ON/OFF” button on the fryer vat to “OFF” and skim the shortening to remove any floating crumbs. Consult company’s operational procedure on the recommended amount of FILTER AGENT in the fryer vat and then thoroughly stir the filter agent into the shortening using the skimmer.

CAUTION:



PRIOR TO PROCEEDING TO THE NEXT STEP, DON SAFETY GOGGLES, NEOPRENE-INSULATED GLOVES AND AN APRON.

3. Carefully open the drain valve on the vat to be filtered by turning the **Drain Valve** slightly Counterclockwise. When the bottom of the filter tub is covered open drain valve all the way.
4. When all shortening in the vat has drained into the filter tub, use the **Drain Rod** to stand the wire rack on one side of the vat.
5. Use the drain rod to break up the sediment caked on the inside of the vat and to pull the sediment toward and into the drain valve opening.

6. Use a scraper to remove encrusted material from the sides of the vat and a stropping pad to remove Carbon buildup from the top and sides of the heat mechanism.
7. Once all shortening and debris are drained, turn on the vat pump by flipping toggle switch "ON". The pump will begin to return shortening into the vat with wash wand.
8. Once the vat is clean, turn the **Drain valve** clockwise to the "closed" position to fill vat back up.
9. Turn "OFF" pump by flipping toggle switch to "OFF".
10. Repeat the above procedure for each vat.

NOTE:

If the return flow to the vat is decreased, scrape sediment from the filter screen or pad.

CAUTION:

NEVER USE THE SUCTION HOSE OR ANY OTHER DEVICE TO DRAW THE SHORTENING INTO THE PUMP AND FRYER PLUMBING WITHOUT FIRST GOING THROUGH THE FILTER MEDIA (FILTER SCREEN OR FILTER PAD OR FILTER PAPER). SUSPENDED PARTICLES THAT ARE NOT FILTERED OUT BEFORE ENTERING THE PUMP CAN DAMAGE THE PUMP AND CAUSE BLOCKAGES IN THE FRYER PLUMBING.

CAUTION:

REMOVE POWER FROM THE PUMP MOTOR WHEN THE PUMP MOTOR IS TRIPPED. THE POWER TO THE PUMP MOTOR NEEDS TO REMAIN OFF WHEN PRESSING THE MANUAL PUMP MOTOR RESET. AS A SAFETY PERCAUTION, THE WASHWAND NEEDS TO BE DISSCONNECTED FROM THE QUICK DISSCONNECT MALE FITTING.

WARNING:

WARNING IF THE POWER TO THE PUMP MOTOR IS NOT TURNED OFF, HOT SHORTENING WILL SPRAY OUT OF THE WASHWAND VIOLENTLY WHEN RESET BUTTON IS PRESSED.

5.2. WASH WAND OPERATION

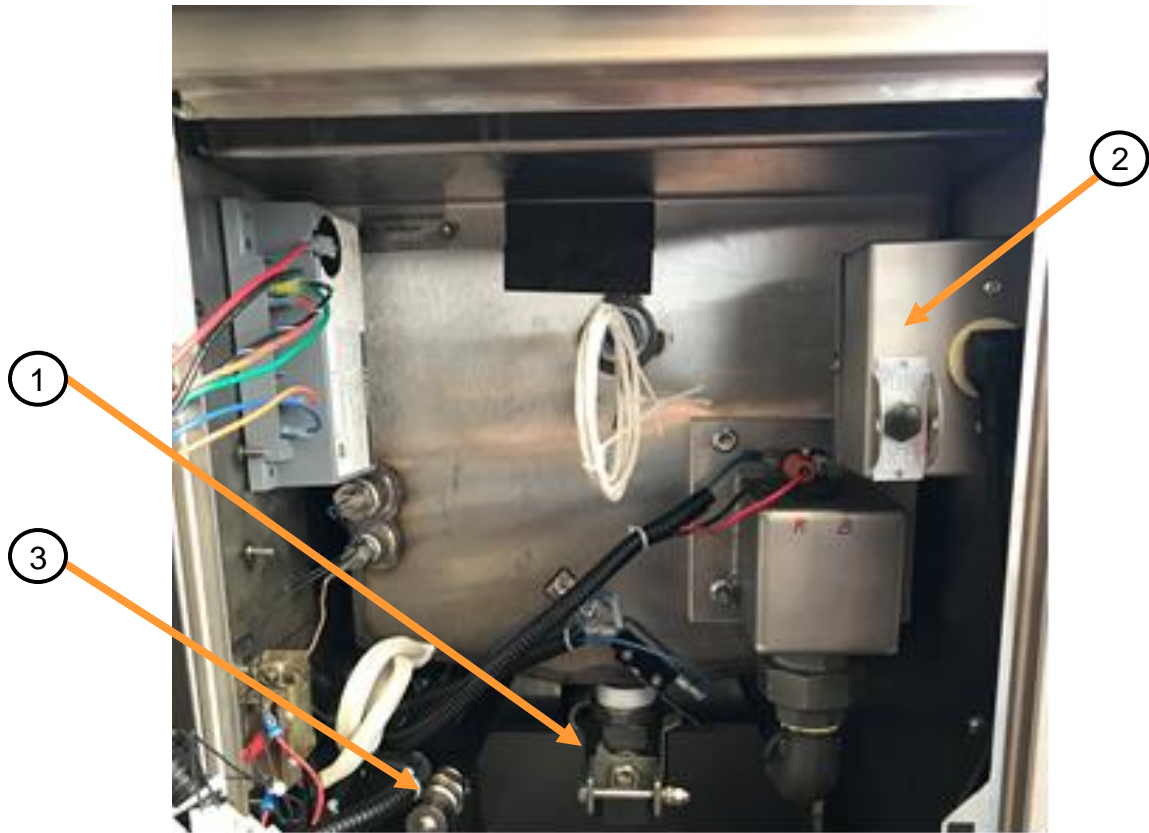

Wash Wand and Filtration Controls

CAUTION: 

1	Drain valve	Operates the main drain valve, which drains the shortening from the vat to the drain trough/filter tub. Need valve handle for operation.
2	Pump Activation Switch (T&R Switch)	Activates the pump to the Wash Wand. NOTE: On a 5-Vat fryer, the Pump Activation Switches (T&R Switch) are located in the same cabinet as the filter tub. Each Pump Activation Switch (T&R Switch) operates independently from any other Pump Activation Switch (T&R Switch) that may be present on the fryer.
3	Wash Wand Connection	(Shown with Wash Wand NOT installed) NOTE: The Wash Wand must be installed prior to turning the Wash Wand activating the Pump Activation Switch (T&R Switch).

Wash Wand Operation Procedure

1. Turn on the computer on the vat that is to be filtered
2. Turn "ON/Off" toggle switch to "Off".
3. Open the drain valve on the vat by turning the drain lever counterclockwise. Gradually open the drain valve and allow shortening to enter the drain trough/filter tub.
4. Insert the wash wand hose end into the wash wand connection fitting.
5. Place the wash wand hose nozzle into the fryer and hold the nozzle firmly against an inner wall. This will prevent the hose from recoiling upward when the filter pump is turned on.
6. Turn the Pump Activation Switch to the "on" position. Shortening will begin to flow into the wash wand.

NOTE:

If the wash wand handle is closed prior to the pump on, the pump motor's thermal reset sensor will trip and disable the motor. Once this happens, it will be necessary to wait for the motor to cool and then to press the "Reset" switch on the end of the motor before the motor will be operational again.

NOTE:

A drain rod may be required to force sediment through the drain valve.

7. Once sediment is removed, turn the drain lever clockwise to the "closed" position. This will allow the vat to refill.
8. When the vat is filled, switch the Pump Activation Switch to "off".

CAUTION:



ALWAYS POINT THE WASH WAND TOWARDS THE INNER SIDE WALL OF THE VAT AND AWAY FROM YOURSELF AND CO-WORKERS.

9. Disconnect the wash wand from the wash from the wash wand connection fitting.

NOTE:

When disconnected, let oil in the wash wand hose drain back into the filter tub.

10. Repeat the above steps for each vat.

NOTE:

If the return flow to the vat is decreased, scrape sediment from the filter screen or pad.

6. CLEANING

6.1. GENERAL CLEANING

Any item of equipment operates and lasts longer when kept clean and properly maintained, and the Ultrafryer is no exception.

In order for this fryer to provide years of trouble-free service, it must be CLEANED and MAINTAINED according to the instructions listed below.

DAILY

- 1) Clean the fryer surfaces periodically during operating hours with a solution of sanitizer and hot water, and at closing with stainless steel cleaner. If necessary, use a dampened type 7447 RED or 7440 BROWN (heavy duty) Scotch brite pad to remove encrusted material. DO NOT use steel wool, abrasive cloths, cleaners, powders, metal knife, spatula or any metal object to scrape stainless steel! Scratches on stainless steel are almost impossible to remove.
- 2) Filter the shortening in each fryer once a day or according to Company Policy.

CAUTION:



DO NOT ALLOW ANY CLEANING SOLUTION OR WATER TO SPLASH INTO A VESSEL OF HOT COOKING OIL, AS IT WILL CONTAMINATE THE OIL AND MAY CAUSE THE OIL TO SPLATTER CAUSING SEVERE BURNS.

WEEKLY

- 1) BOIL-OUT the fryer vat using Boil Out Compound according to procedures in the cleaning manual provided by the chemical provider.
- 2) Perform steps 1 and 2 listed above under the Daily Cleaning.

7. PREVENTIVE MAINTENANCE AND TROUBLESHOOTING

7.1. PREVENTIVE MAINTENANCE

Minimal maintenance is required on the fryer because of its design and the materials used in the manufacturing process. However, some preventive maintenance and inspection must be performed periodically to prevent break downs which could curtail food sales. Any preventive maintenance or inspection should be accomplished with **CAUTION** while the fryer is in operation since **HOT** liquid shortening could cause severe burns. If service or repair is required, all gas and electric power **MUST BE TURNED OFF PRIOR** to performing any service or repair. The following chart describes the minimum items to be inspected and the inspection interval:

Table 1. Daily Preventive Maintenance Inspection Schedule.

Item	Inspection Description
Grease Filters	Clean grease filters in the exhaust hood evening and allow them to dry overnight

Filter Tube	Thoroughly clean the filter tub assembly prior to leaving the store at closing.
-------------	---

NOTE:

Ensure the wash down hose is hung in an upright position (by one end) so shortening can drain into a container.

Table 2. Weekly Preventive Maintenance Inspection Schedule.

Item	Inspection Description
Drain Valve	Determine that drain valve is securely attached and that it can be easily operated.
Drain Hoses	Inspect the suction line, wash wand and, if applicable, the shortening disposal hoses for any evidence of deterioration.
Temperature Sensing Probes and Dry Fire	During boil-out of the fryer, inspect the temperature, high limit sensing and Dry Fire probes for any visual damage.

7.2. TROUBLESHOOTING

7.2.1 GENERAL: The problems and possible solutions listed in the troubleshooting chart below are typical problems that are frequently encountered. **ONLY** qualified repairmen are to use the troubleshooting chart to repair this fryer. In the event a main burner malfunction occurs, perform the following checks **PRIOR** to contacting a repairman:

1. Check that the fryer electrical plug is connected to an electrical receptacle.
2. Ensure the applicable Circuit Breaker is in the **ON** position and that the fryer ON/OFF switch is in the **ON** position.
3. Ensure the applicable fryer control has been placed in the **EXIT MELT** mode.
4. Ensure the gas supply line quick-disconnect coupling is **SEATED** on the gas manifold fitting.
5. Determine that the blower is operating.

TROUBLESHOOTING CHART: Should a problem occur that cannot be corrected after performing the above CHECKS, contact an **AUTHORIZED** repairman and/or Ultrafryer Systems Customer Service 1-800-525-8130 and provide the information acquired while performing these checks.

<u>ITEM</u>	<u>PROBLEMS</u>	<u>POSSIBLE SOLUTIONS</u>
1	Ignition Lockout	1.) Harness connection to gas valve 2.) Gas valve or gas pressure 3.) All harness connections 4.) Electrode 5.) Interconnecting wiring malfunction 6.) Ignition module malfunction 8.) Grounding Status
2	No spark, No blower	1.) Harness connections 2.) Probe lead wires 3.) Open probe 4.) Controller
3	“Puffing” during normal start up	1.) Incorrect gas pressure 2.) Cracked electrode 3.) Electrode gap exceeded
4	Burner lights but will not maintain flame	1.) Igniter/flame sense misalignment 2.) Insufficient gas pressure
5	Excessive Heat	1.) Incorrect temperature offset selected 2.) Set Temperature exceeding 400 deg F 3.) Temperature probe malfunction 4.) Cooking control malfunction 5.) Interface board malfunction 6.) Gas pressure incorrect
6	Low heat	1.) Incorrect temperature offset selected 2.) Cooking control malfunction 3.) Temperature probe malfunction 4.) High limit tripped 5.) Gas pressure incorrect
7	Intermittent problems	1.) High ambient temperatures 2.) Wiring connections loose
8	No power to cooking control, fryer does not heat	1.) Is displayed “OFF” when Powered 2.) Main circuit breaker off 3.) Transformer inoperative 4.) Interconnecting wiring malfunction
9	High limit thermostat shutting down system	1.) Shortening level below minimum fill line 2.) Probe malfunction 3.) Controller malfunction 4.) Faulty hi limit.

10	Excessive time to melt shortening	1.) Melt cycle timing incorrect 2.) Insufficient gas pressure 3.) Probe malfunction 4.) Control malfunction
11	Dry fire fry tank	1.) No shortening in vat 2.) Control malfunction 3.) Probe malfunction
12	Blower replacement	1.) Pumpset connectivity 2.) Reset throttle to required depth NOTE: Bottom out on throttle. Count number of turns on throttle to reset.

CAUTION:



ENSURE REPAIRMEN ARE ADVISED THAT FRYER RESTRAINTS MUST BE DISCONNECTED/CONNECTED. IF A FRYER IS TO BE MOVED DURING MAINTENANCE OR REPAIR, ADVISE REPAIRMAN THAT ELECTRICAL POWER AND GAS MUST BE TURNED OFF PRIOR TO PERFORMING ANY MAINTENANCE OR REPAIR.

8. TECHNICAL ASSISTANCE, WARRANTY PARTS & REPLACEMENT PARTS ASSISTANCE

8.1. TECHNICAL ASSISTANCE

Contact an authorized service agent or the Customer Service Department at **1-800-525-8130** for technical assistance.

E-mail technical assistance at: TECHSERV@ULTRAFRYER.COM

8.2. WARRANTY PARTS

Contact the Customer Service Department, at **1-800-525-8130** for Parts Assistance.

E-mail Customer Service at: TECHSERV@ULTRAFRYER.COM

8.3. REPLACEMENT PARTS

Contact the Customer Service Department, at **1-800-525-8130** for Replacement Parts Assistance.

9. RECOMMENDED SPARE PARTS

9.1. RECOMMENDED SPARE PARTS

To minimize downtime on the premix gas fryer upon failure of a component part, at least one (1) of the following items should be kept as a spare part in a local area:

PREMIX GAS FRYER RECOMMENDED SPARE PARTS LISTING	
<u>DESCRIPTION</u>	<u>PN</u>
	-
Blower Premix 5.0 Power Burner and Gas Valve	17A033
Gasket, Blower Motor / Manifold IDE	22A810
Burner, Infrared	22A818
Rod, Ignitor Infrared Burner F/22A818	18611
Gasket, Mount infrared Burner	22A817
Module, Ignitor Spark Single	18A385
Relay 24VAC Flange Mounted	18A034
Delay on make	18A102
Control, 24VAC Universal Gas Blower (PWM)	23A462
Switch, Air Pressure	18A291
Switch, HI Limit	18A096
Probe, Temp Thermistor	18A006
Relay, 120V 50/60Hz	18A020
Relay, 24V DC 10AMP SPDT computer	23A023
Computer, Cook U402 (Touch Screen)	22A838
Oil Proximity Kit, Control Dry Fire	23A510

10. PARTS IDENTIFICATION

10.1. F-IRC-14 - CONTROL PANEL

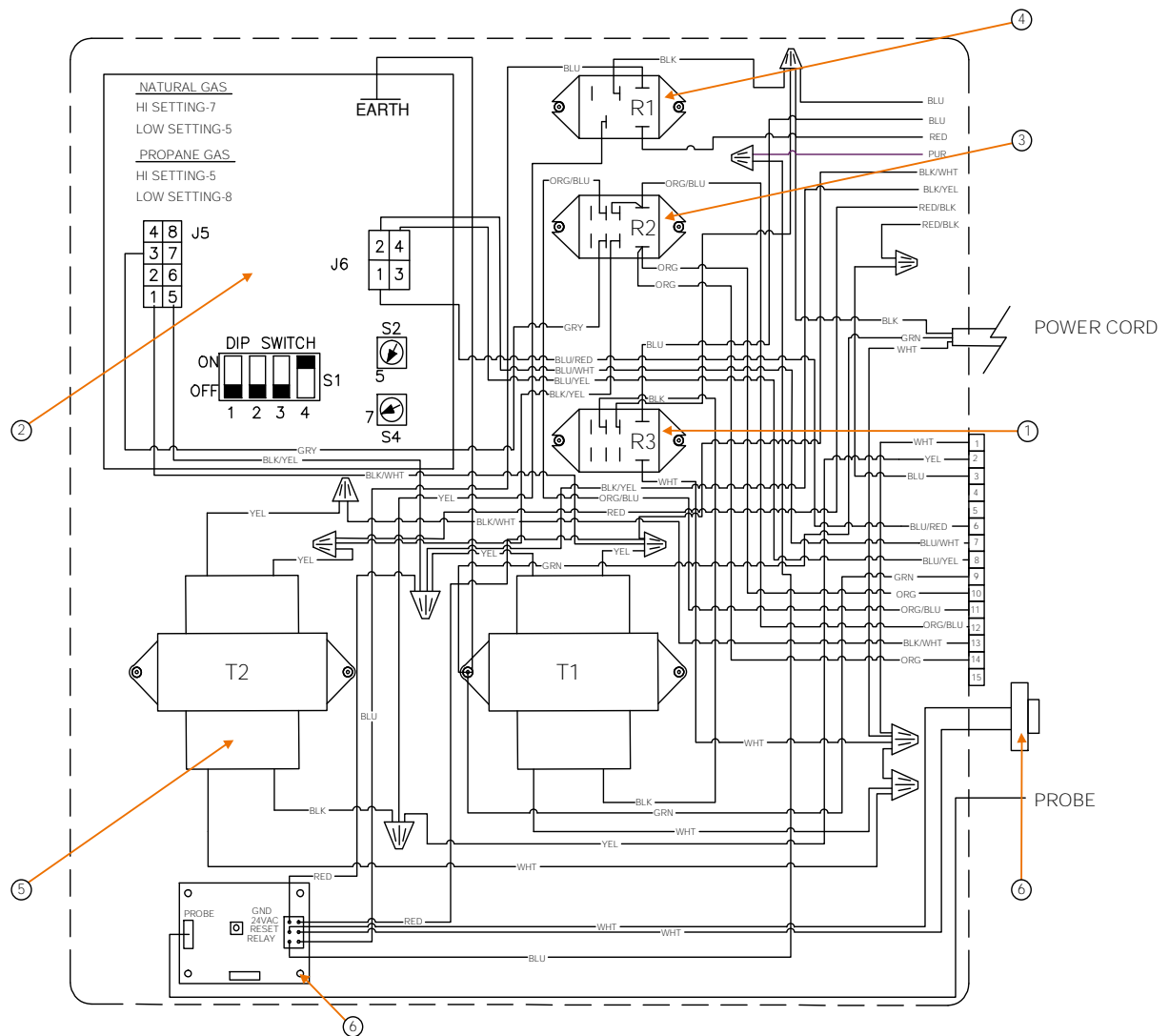

ITEM	DESCRIPTION
1	18A020 Relay, 120V 50/60Hz
2	23A462 Control, 24VAC Universal Gas Blower (PWM)
3	18A034 Relay, 24VAC Flange-mounted
4	23A023 Relay, 24V DC 10 AMP SPDT Computer
5	18A047 Transformer, Fast Wiring Harness
6	23A510 Oil Proximity Kit, Control Dry Fire/Sensor Probe

10.2. CABINET FRONT VIEW



ITEM	DESCRIPTION
1	19D042 Box Mount, Infrared Burner
2	22A818 Burner Infrared
3	18611 Rod, Ignitor Infrared Burner
4	22A817 Gasket, Mount Burner Box
5	12D219 Box, Assy, Pump Control Switch w/Receptacle
6	18A006 Probe Thermistor
7	18A096 Switch, Hi Limit
8	24A270 Fitting, Compression Male 3/8 NPT
9	23A510 Oil, Proximity Switch

10.3. CABINET REAR VIEW

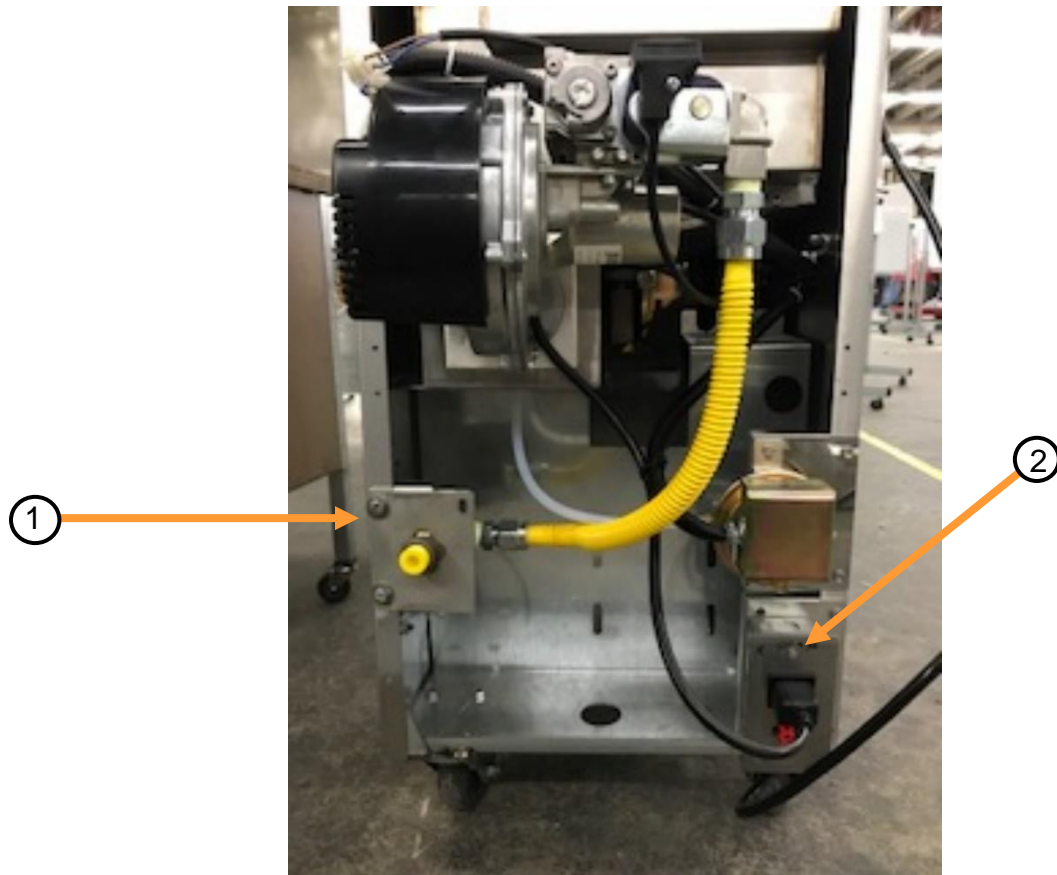

ITEM	DESCRIPTION
1	12D132 Box , Assembly Pump Control
2	19D031 Bracket, Gas Line 14in/20 X 17.35 IDE/IR 18 FM.

10.4. CABINET REAR VIEW

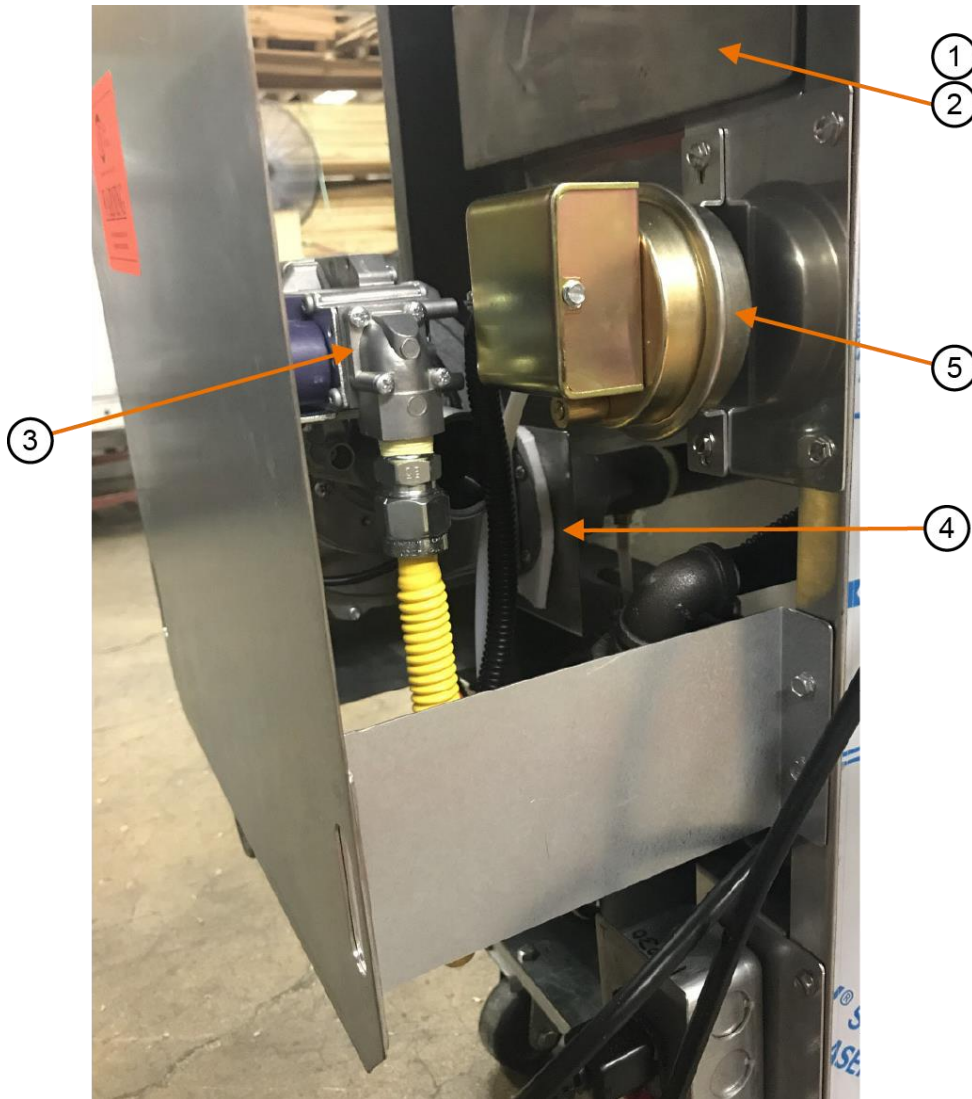

ITEM	DESCRIPTION
1	19D211 Box, Blower w/flue
2	22A819 Gasket, Blower Box
3	17A033 Blower Premix 5.0 Power Burner/Gas Valve
4	22A810 Gasket, Blower Motor/Manifold
5	18A291 Switch, Air Pressure SMD 1204

SERVICE PROCEDURES AND ADJUSTMENTS

11.1. HARMONIC TONE

Harmonic Tone (HUM) at first start, fryer will begin heating in low fire and a few seconds later go to high fire. There will be a harmonic tone that is normal to hear. As fryer continues to heat, harmonic tone will dissipate and become less noticeable.

11.2. GAS VALVE

WARNING:



DISCONNECT THE ELECTRICAL POWER TO THE FRYER.

WARNING:



SHUT OFF THE GAS BEFORE SERVICING THE FRYER.

WARNING:



**ALL GAS JOINTS DISTURBED DURING SERVICING MUST BE CHECKED FOR LEAKS.
CHECK WITH A SOAP AND WATER SOLUTION (BUBBLES).
DO NOT USE AN OPEN FLAME**

The gas valve is considered part of the Blower Premix 5.0 Power Burner and Gas Valve assembly. If the gas valve fails and needs to be replaced, you must order a complete blower / gas valve assembly (burner). The reason for this is every blower / gas valve assembly (burner) is set up at the factory to operate at the most efficient level possible. This set up procedure can not be duplicated in the field.

11.3. MODULATING GAS VALVE ADJUSTMENTS

WARNING:



DISCONNECT THE ELECTRICAL POWER TO THE FRYER

WARNING:



SHUT OFF THE GAS BEFORE SERVICING THE FRYER.

WARNING:



**ALL GAS JOINTS DISTURBED DURING SERVICING MUST BE CHECKED FOR LEAKS.
CHECK WITH A SOAP AND WATER SOLUTION (BUBBLES).
DO NOT USE AN OPEN FLAME**

The modulating gas valve is adjustable at the factory and requires no adjustment. If the modulating gas valve needs to be replaced, the new gas valve from the factory will be adjusted properly and will only need to have the gas pressure verified coming into the gas valve.

11.4. TEMPERATURE PROBE SETTING

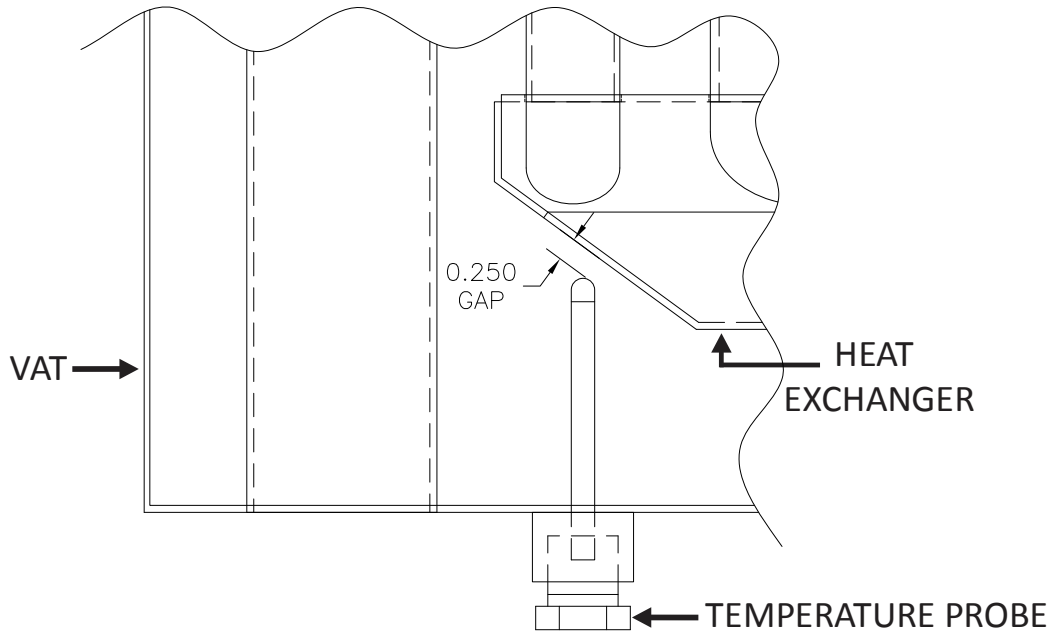

11.5. HI LIMIT PROBE SETTING

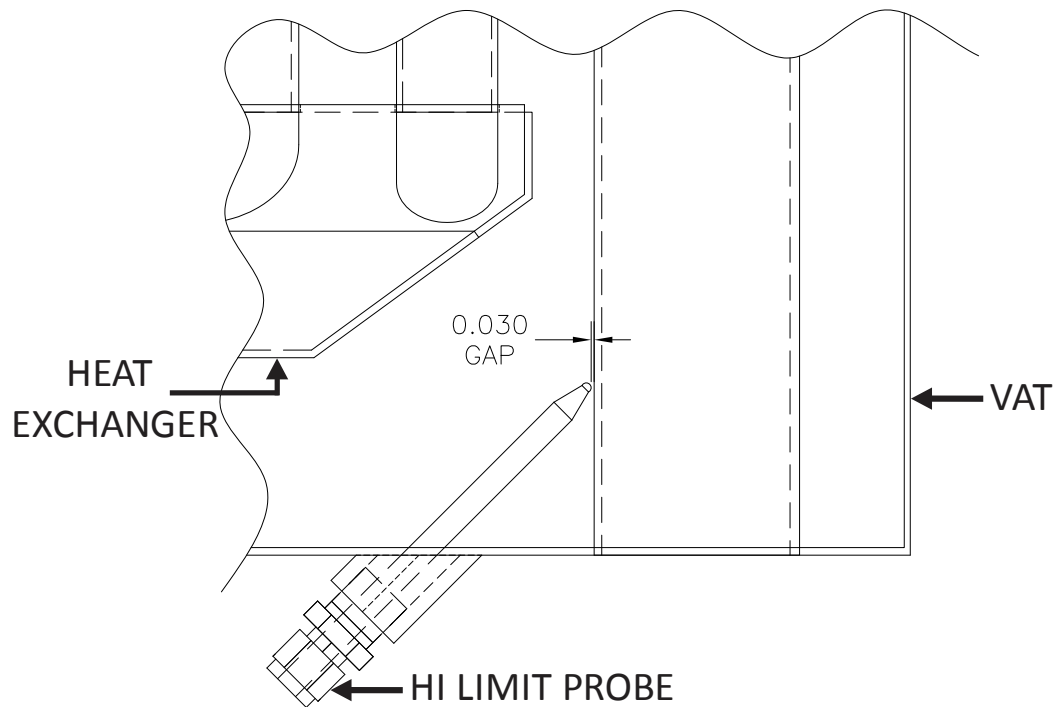

11.6. INFRARED BURNER SPARK IGNITOR AND FLAME SENSOR SETTING

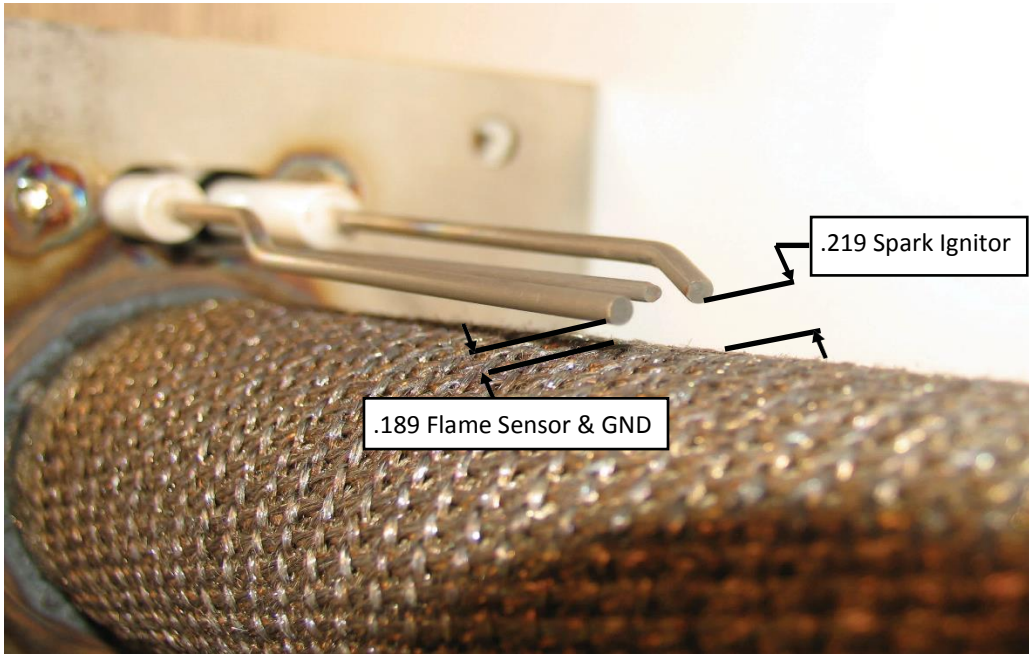

11.7. GROUND ROD GROUND WIRE CONNECTION

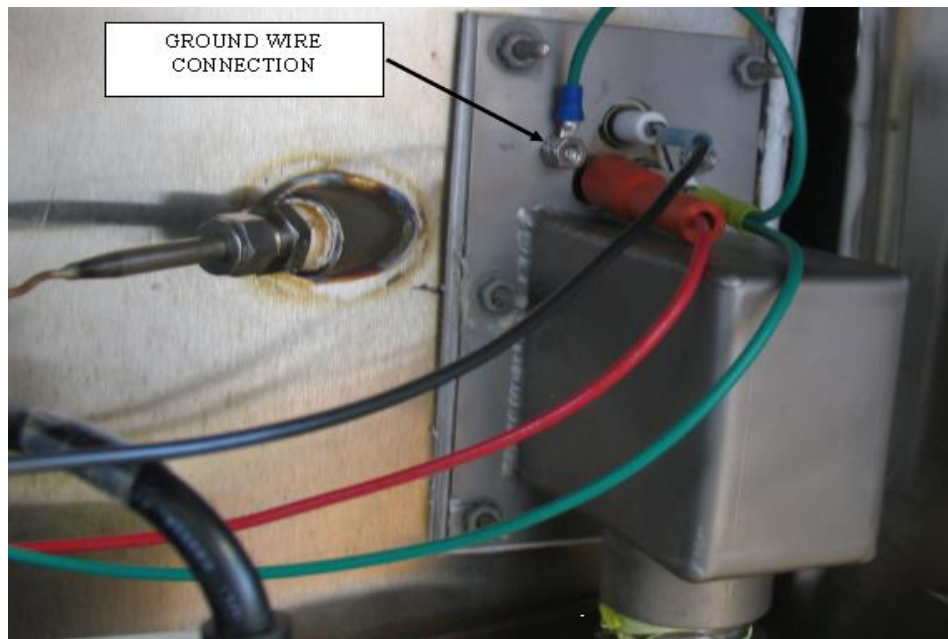

11.8. CONTROL, 24 VAC UNIVERSAL GAS BLOWER (PWM) SETTINGS

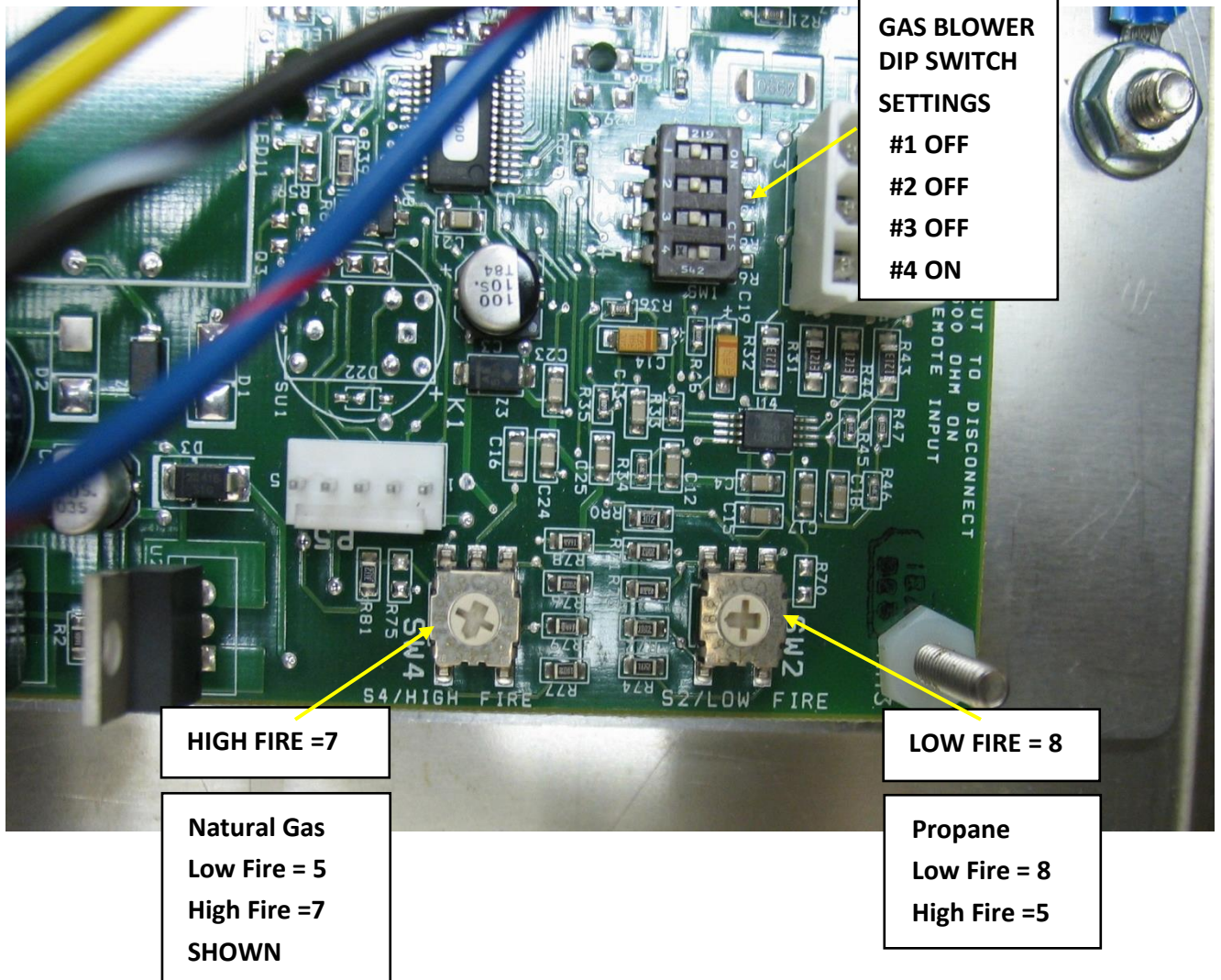

12. LADDER DIAGRAM

12.1. LADDER DIAGRAM

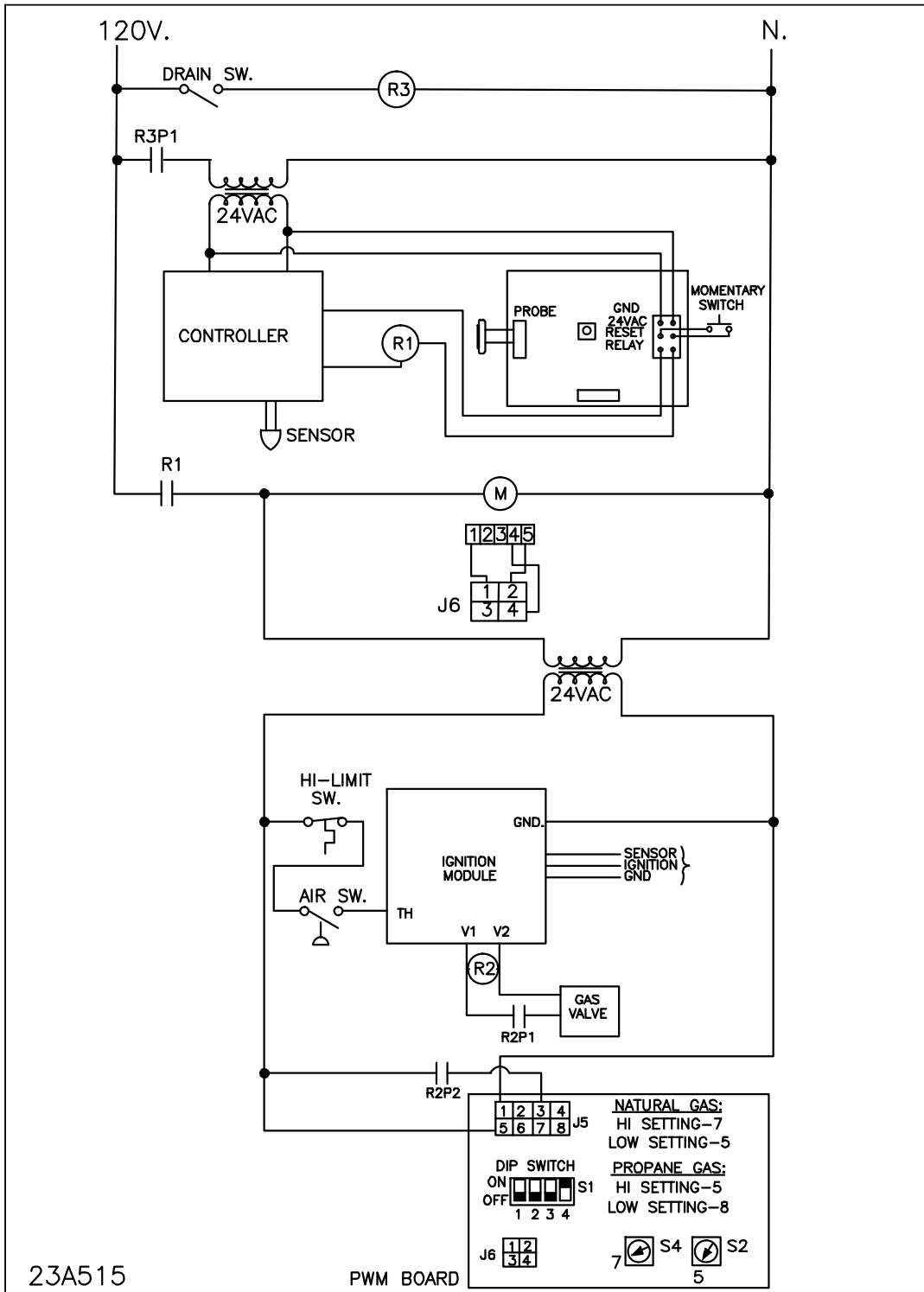

12.2. SCHEMATIC

